



PRELIMINARY SPEC



ATTENTION
OBSERVE PRECAUTIONS
FOR HANDLING
ELECTROSTATIC
DISCHARGE
SENSITIVE
DEVICES

PATENT PENDING



Features

- PLCC-4 PACKAGE.
- SINGLE COLOR.
- HIGH LUMINANCE.
- HIGH POWER, OPERATING CURRENT @ 350mA.
- SUITABLE FOR ALL SMT ASSEMBLY METHODS.
- PACKAGE : 500PCS / REEL.
- MOISTURE SENSITIVITY LEVEL : LEVEL 4.
- RoHS COMPLIANT.



Outline Drawings

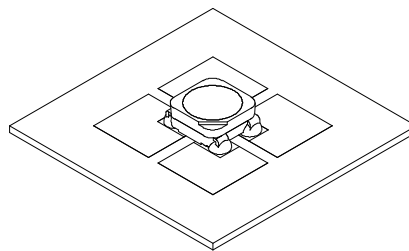
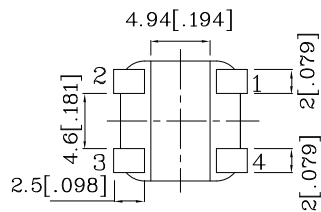
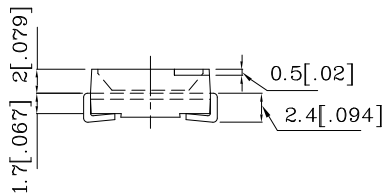
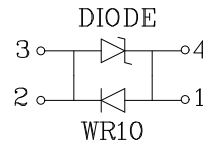
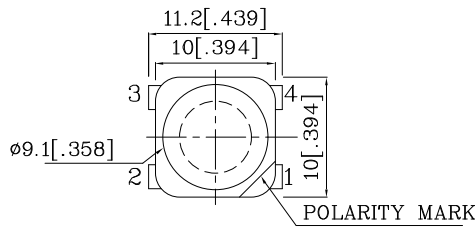

Notes:

1. All dimensions are in millimeters (inches).
2. Tolerance is $\pm 0.25(0.01)$ unless otherwise noted.
3. The device has a single mounting surface. The device must be mounted according to the specifications.
4. Specifications are subject to change without notice.



Applications

- Traffic signaling.
- Backlighting (illuminated advertising , general lighting).
- Interior and exterior automotive lighting.
- Substitution of micro incandescent lamps.
- Portable light source (e.g. bicycle flashlight).
- Signal and symbol luminaire for orientation.
- Marker lights (e.g. steps, exit ways, etc).
- Decorative and entertainment lighting.
- Indoor and outdoor commercial and residential architectural lighting.

Application Notes

- Pressure or stress can damage the encapsulating material and affect the reliability of the LED.
Precaution should be taken to avoid pressure on the LED encapsulating surface.
- Static electricity and surge damage the LEDs.
It is recommended to use a wrist band or anti-electrostatic glove when handling the LEDs.
All devices, equipment and machinery must be electrically grounded.
- Handling Indications
Use proper handling techniques to prevent damage to the LED surface. Minimize mechanical stress on the LED surface during processing and handling. Do not touch the emitting surface with sharp objects to avoid scratching or damaging the LED.



Figure 1

In general, LEDs should be handled by the sides of the package. Handling instruments should not touch the emitting surface of the LED package.



Figure 2

For automated pick-and-place machines, the pickup nozzle should be larger than the size of the LED reflector area to avoid placing excess pressure on the LED surface.



Part Number	Emitting Color	Emitting Material	Lens-color	Luminous Intensity (IF=350mA) [1]		Luminous Flux (IF=350mA)		Viewing Angle 2 θ 1/2 [2]
				cd		lm		
				min.	typ.	min.	typ.	
XZWR10X95W	Warm White	InGaAlN	Water Clear	6.7	11	20	33	120°

Absolute Maximum Ratings at TA=25°C

Parameter	Symbol	Value	Unit
Power Dissipation	Pt	1.25	W
Junction Temperature	TJ	110	°C
Operating Temperature	Top	-40 To +85	°C
Storage Temperature	Tstg	-40 To +85	°C
DC Forward Current[1]	IF	350	mA
Peak Forward Current [3]	IFM	500	mA
Thermal Resistance [1]	Rth	9	°C/W
Electrostatic Discharge Threshold (HBM)		8000	V

Notes:

1.Results from mounting on PC board FR4(pad size ≥ 100mm² per pad), mounted on pc board-metal core PCB is recommend for lowest thermal Resistance.

2.θ 1/2 is the angle from optical centerline where the luminous intensity is 1/2 the optical centerline value.

3.1/10 Duty Cycle, 0.1ms Pulse Width.

Electrical / Optical Characteristics at TA=25°C

Parameter	Symbol	Value	Unit
Chromaticity Coordinate x acc.to CIE1931 IF=350mA [Typ.]	X	0.41	-
Chromaticity Coordinate y acc.to CIE1931 IF=350mA [Typ.]	Y	0.39	-
Forward Voltage IF=350mA [Min.]	VF	2.8	V
Forward Voltage IF=350mA [Typ.]		3.2	
Forward Voltage IF=350mA [Max.]		3.6	
Temperature Coefficient Of x IF=350mA, -10 ° C ≤ T ≤ 100 ° C [Typ.]	TCx	-0.6	10 ⁻³ /° C
Temperature Coefficient Of y IF=350mA, -10 ° C ≤ T ≤ 100 ° C [Typ.]	TCy	-0.2	10 ⁻³ /° C
Temperature Coefficient Of VF IF=350mA, -10 ° C ≤ T ≤ 100 ° C [Typ.]	TCv	-3.2	mV/° C



XZWR10X95W

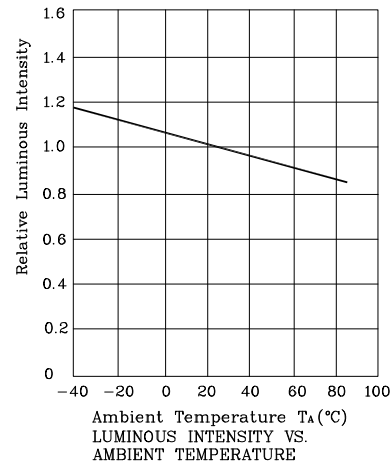
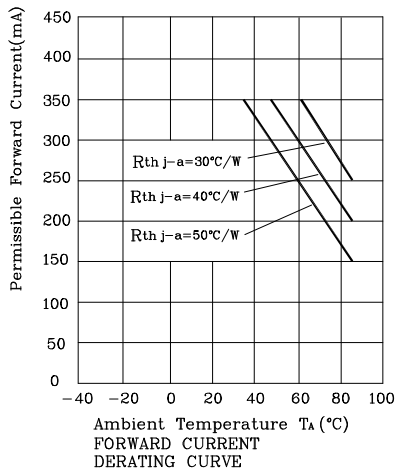
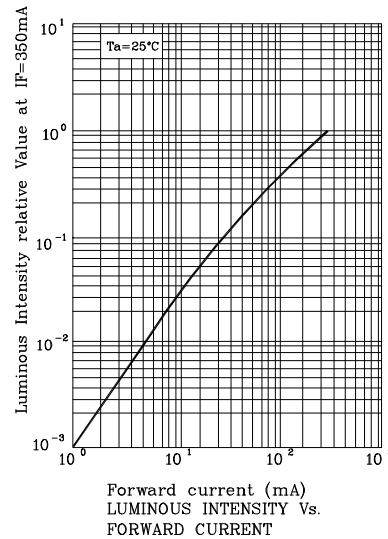
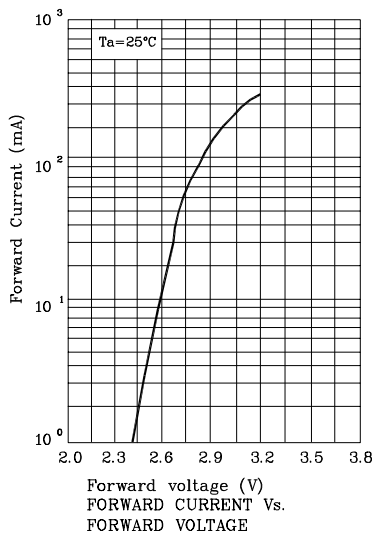
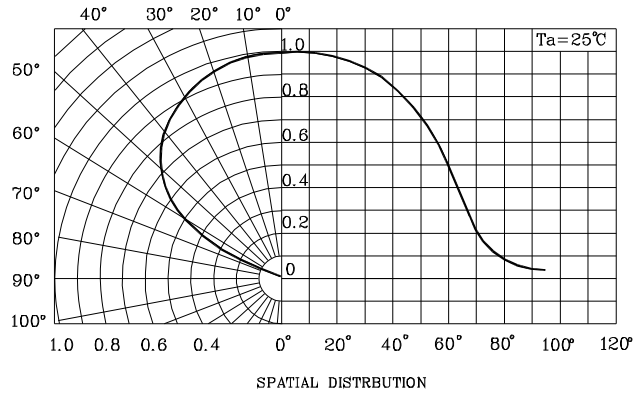



XZWR10X95W

Warm White CIE

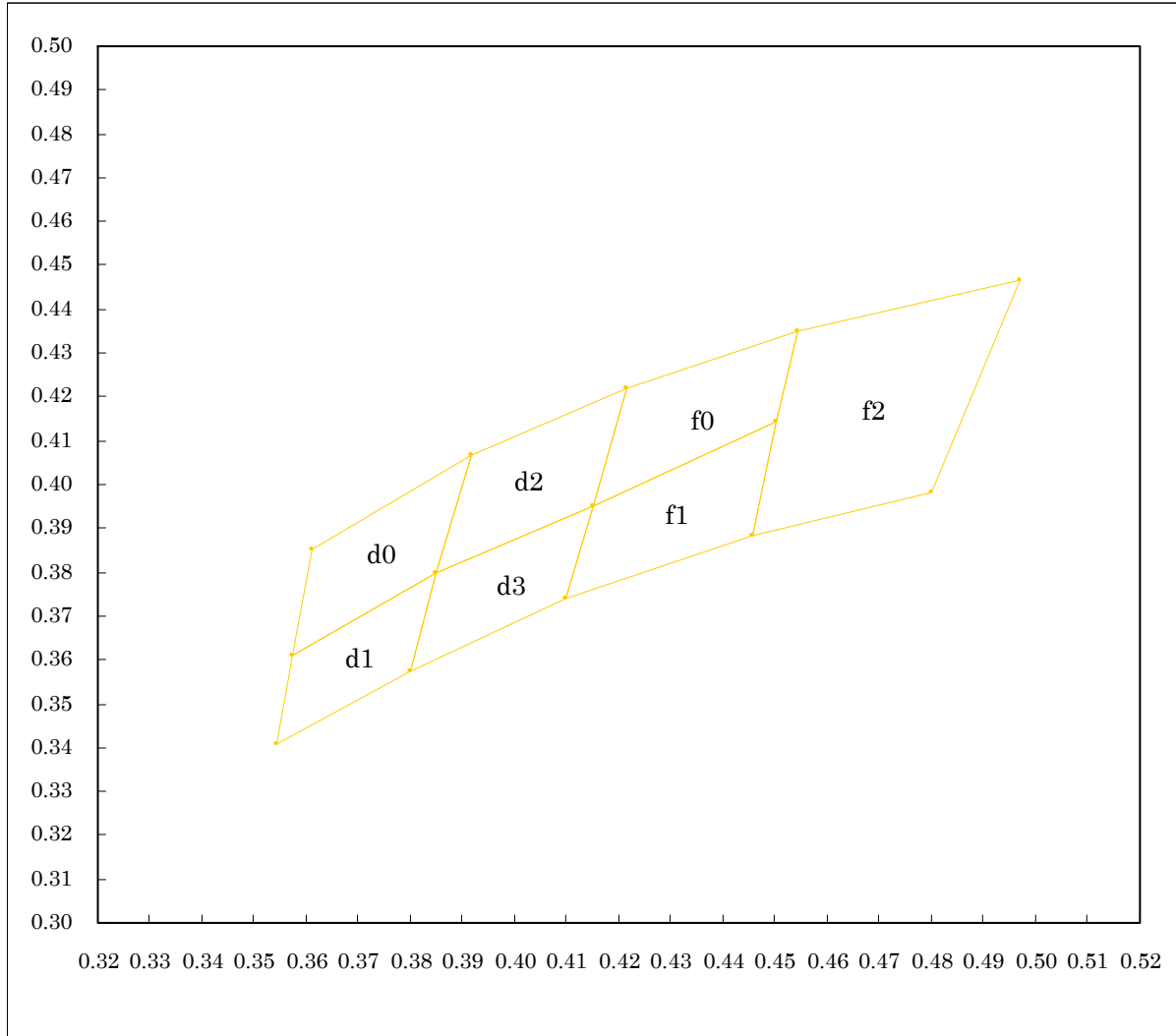

d0				
x	0.3610	0.3575	0.3870	0.3942
y	0.3850	0.3612	0.3820	0.4068
Reference CCT : 3900~4700K				

d1				
x	0.3575	0.3545	0.3800	0.3870
y	0.3612	0.3408	0.3580	0.3820
Reference CCT : 3900~4700K				

d2				
x	0.3870	0.4254	0.4350	0.3942
y	0.3820	0.4044	0.4260	0.4068
Reference CCT : 3200~3900K				

d3				
x	0.4254	0.3870	0.3800	0.4119
y	0.4044	0.3820	0.3580	0.3730
Reference CCT : 3200~3900K				

f0				
x	0.4350	0.4732	0.4600	0.4254
y	0.4260	0.4398	0.4152	0.4044
Reference CCT : 2700~3200K				

f1				
x	0.4600	0.4254	0.4119	0.4440
y	0.4152	0.4044	0.3730	0.3847
Reference CCT : 2700~3200K				

f2				
x	0.4732	0.4600	0.4440	0.4800
y	0.4398	0.4152	0.3847	0.3960
Reference CCT : 2300~2700K				

Reflow Soldering Profile For Lead-free SMT Process.

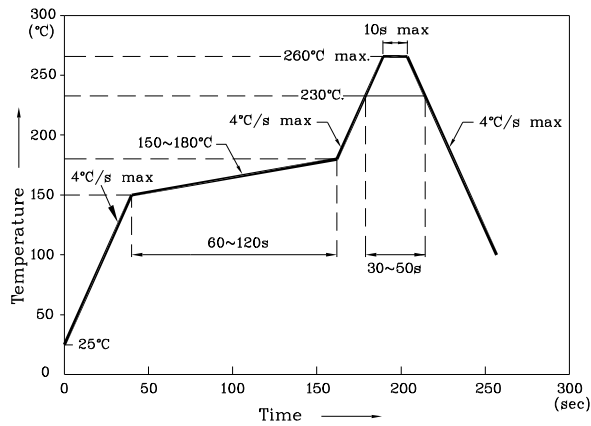

Notes:

1. Maximum soldering temperature should not exceed 260°C.
2. Recommended reflow temperature: 145°C-260°C.
3. Do not put stress to the epoxy resin during high temperatures conditions.

❖ Recommended Soldering Pattern
(Units: mm ; Tolerance: ± 0.1)

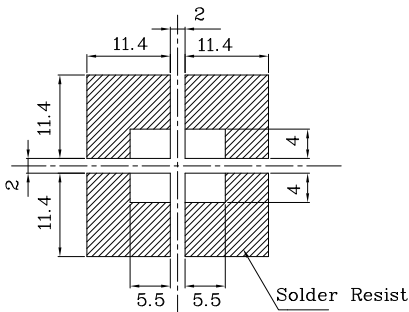

❖ Reel Dimension

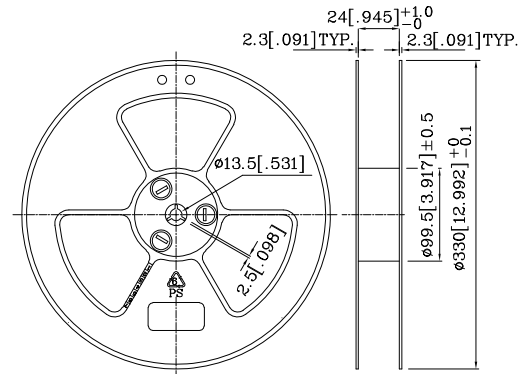

❖ Tape Specification (Units : mm)

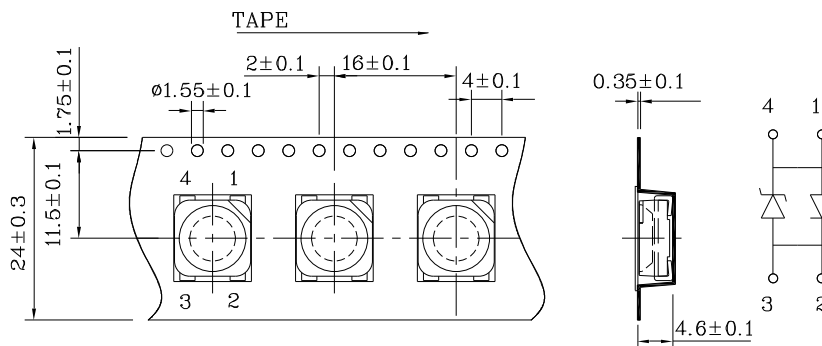

Remarks:

If special sorting is required (e.g. binning based on forward voltage, luminous intensity / luminous flux or chromaticity), the typical accuracy of the sorting process is as follows:

1. Measurement tolerance of the chromaticity coordinates is ±0.01 .
2. Luminous Intensity / Luminous Flux: +/-15%
3. Forward Voltage: +/-0.1V

Note: Accuracy may depend on the sorting parameters.



PACKING & LABEL SPECIFICATIONS

XZWR10X95W

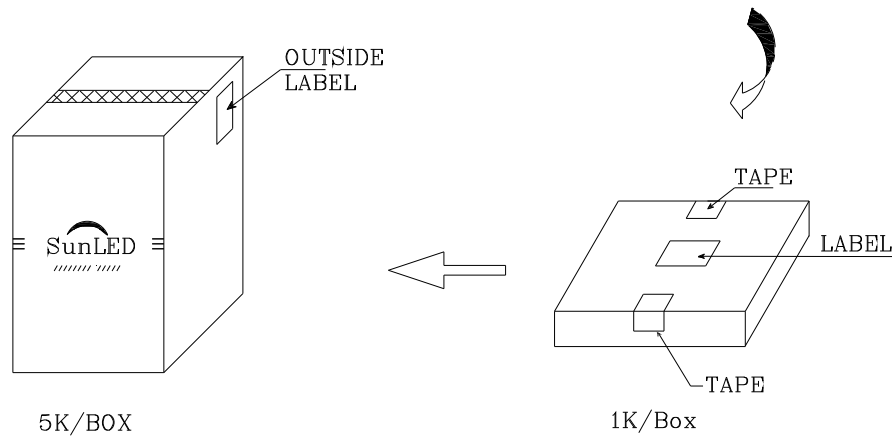
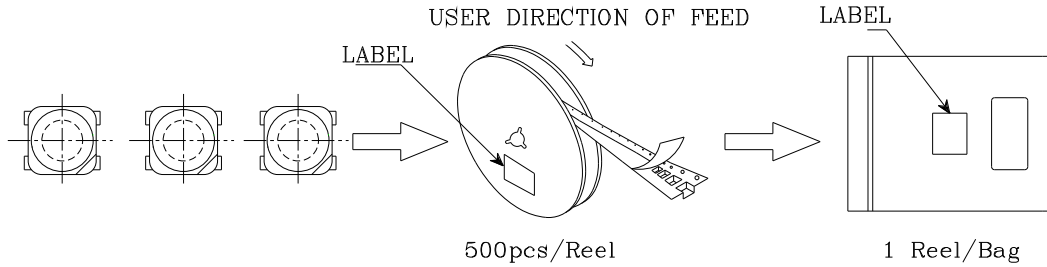

P/NO : XZxxx95x	
QTY : 500 pcs	CODE: XXX
S/N : XX	
LOT NO :	
 XXXXXXXXXXXXXXXXXXXXXXXXXXXX	
RoHS Compliant	