

Features

- Ideal for indication light on hand held products
- Long life and robust package
- Variety of lens types and color choices available
- Package : 1500pcs / reel
- Black case.
- Moisture sensitivity level : level 3
- RoHS compliant



ATTENTION
OBSERVE PRECAUTIONS
FOR HANDLING
ELECTROSTATIC
DISCHARGE
SENSITIVE
DEVICES

Package Schematics

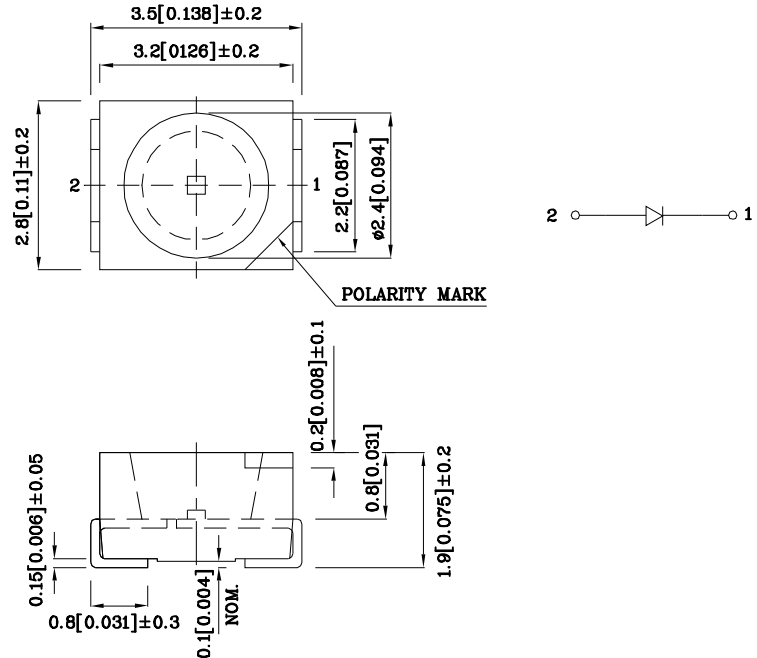

Notes:

1. All dimensions are in millimeters (inches).
2. Tolerance is ±0.25(0.01") unless otherwise noted.
3. Specifications are subject to change without notice.

Absolute Maximum Ratings (T _A =25°C)		FRA (InGaN)	Unit
Reverse Voltage	V _R	5	V
Forward Current	I _F	30	mA
Forward Current (Peak) 1/10 Duty Cycle 0.1ms Pulse Width	i _{FS}	100	mA
Power Dissipation	P _D	120	mW
Operating Temperature	T _A	-40 ~ +85	°C
Storage Temperature	T _{stg}	-40 ~ +85	

Operating Characteristics (T _A =25°C)		FRA (InGaN)	Unit
Forward Voltage (Typ.) (I _F =20mA)	V _F	3.3	V
Forward Voltage (Max.) (I _F =20mA)	V _F	4.0	V
Reverse Current (Max.) (V _R =5V)	I _R	50	uA
Chromaticity Coordinates (Typ.)	x	0.18	
	y	0.29	
Capacitance (Typ.) (V _F =0V, f=1MHz)	C	100	pF

Part Number	Emitting Color	Emitting Material	Lens-color	Luminous Intensity (I _F =20mA) mcd		Viewing Angle 2 θ 1/2
				min.	typ.	
XZFRA45SBBA	Blue	InGaN	Water Clear	350	497	120°

Handling Precautions

Compare to epoxy encapsulant that is hard and brittle, silicone is softer and flexible. Although its characteristic significantly reduces thermal stress, it is more susceptible to damage by external mechanical force.

As a result, special handling precautions need to be observed during assembly using silicone encapsulated LED products. Failure to comply might lead to damage and premature failure of the LED.

1. Handle the component along the side surfaces by using forceps or appropriate tools.

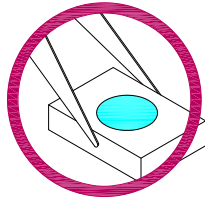

2. Do not directly touch or handle the silicone lens surface. It may damage the internal circuitry.

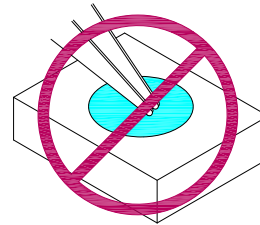
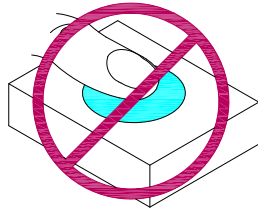

3. Do not stack together assembled PCBs containing exposed LEDs. Impact may scratch the silicone lens or damage the internal circuitry.

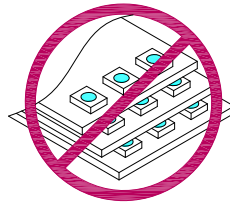

4.1. The outer diameter of the SMD pickup nozzle should not exceed the size of the LED to prevent air leaks. The inner diameter of the nozzle should be as large as possible.

4.2. A pliable material is suggested for the nozzle tip to avoid scratching or damaging the LED surface during pickup.

4.3. The dimensions of the component must be accurately programmed in the pick-and-place machine to insure precise pickup and avoid damage during production.

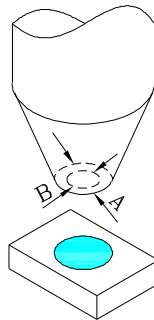

5. As silicone encapsulation is permeable to gases, some corrosive substances such as H₂S might corrode silver plating of leadframe. Special care should be taken if an LED with silicone encapsulation is to be used near such substances.

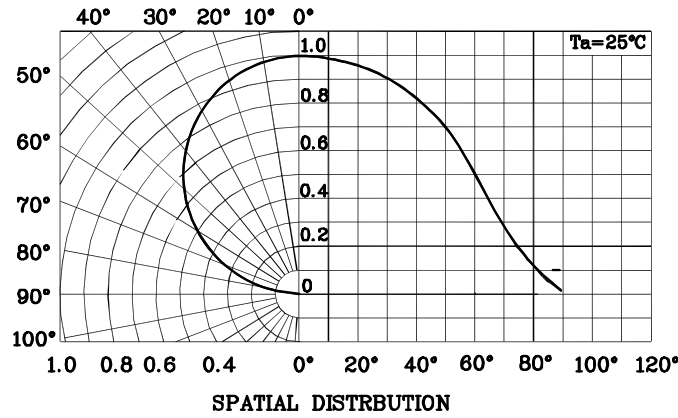

❖ FRA

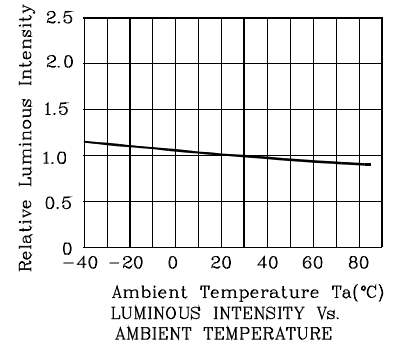
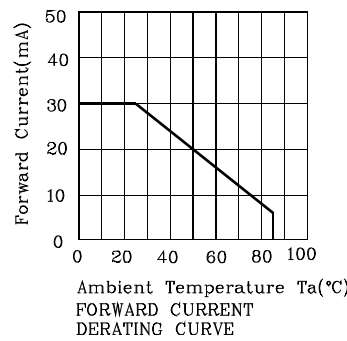
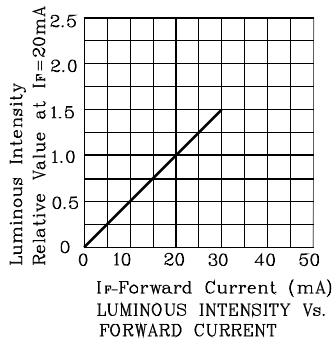
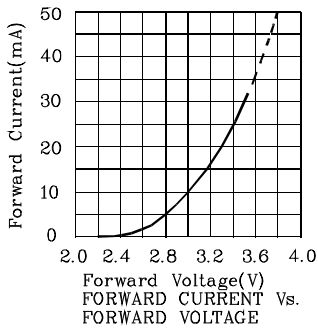

LED is recommended for reflow soldering and soldering profile is shown below.

Reflow Soldering Profile for SMD Products (Pb-Free Components)

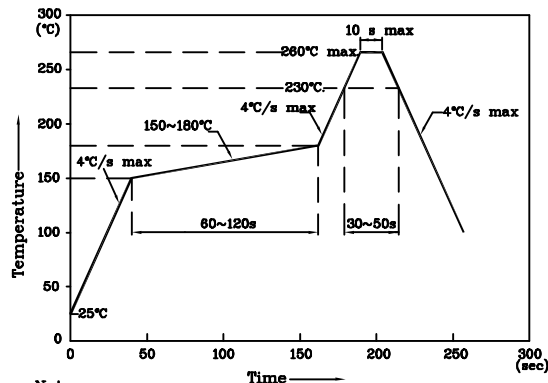

Notes:

1. Maximum soldering temperature should not exceed 260°C
2. Recommended reflow temperature: 145°C-260°C
3. Do not put stress to the epoxy resin during high temperatures conditions

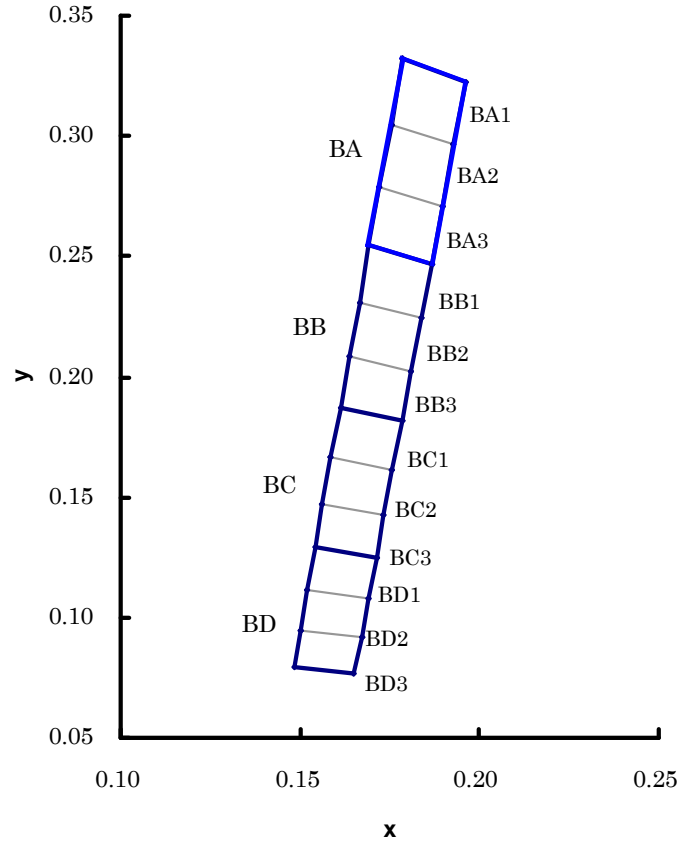

Bin code	x	y	Bin code	x	y	Bin code	x	y	Bin code	x	y
BA1	0.1786	0.3318	BB1	0.1693	0.2543	BC1	0.1612	0.1870	BD1	0.1542	0.1288
	0.1754	0.3048		0.1665	0.2308		0.1587	0.1666		0.1521	0.1114
	0.1928	0.2964		0.1837	0.2241		0.1758	0.1615		0.1691	0.1077
	0.1961	0.3228		0.1866	0.2471		0.1783	0.1814		0.1712	0.1247
BA2	0.1754	0.3048	BB2	0.1665	0.2308	BC2	0.1587	0.1666	BD2	0.1521	0.1114
	0.1723	0.2790		0.1638	0.2084		0.1564	0.1473		0.1501	0.0948
	0.1896	0.2712		0.1810	0.2022		0.1735	0.1427		0.1670	0.0917
	0.1928	0.2964		0.1837	0.2241		0.1758	0.1615		0.1691	0.1077
BA3	0.1723	0.2790	BB3	0.1638	0.2084	BC3	0.1564	0.1473	BD3	0.1501	0.0948
	0.1693	0.2543		0.1612	0.1870		0.1542	0.1288		0.1482	0.0791
	0.1866	0.2471		0.1783	0.1814		0.1712	0.1247		0.1651	0.0765
	0.1896	0.2712		0.1810	0.2022		0.1735	0.1427		0.1670	0.0917

Notes:
 Shipment may contain more than one chromaticity regions.
 Orders for single chromaticity region are generally not accepted.
 Measurement tolerance of the chromaticity coordinates is ± 0.01 .



❖ The device has a single mounting surface.
The device must be mounted according to the specifications.

❖ Recommended Soldering Pattern
(Units : mm; Tolerance: ± 0.1)

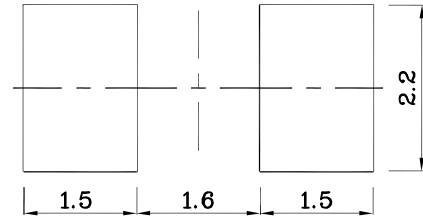
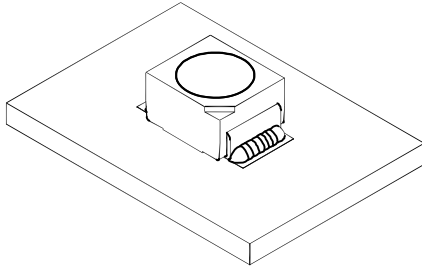

❖ Reel Dimension

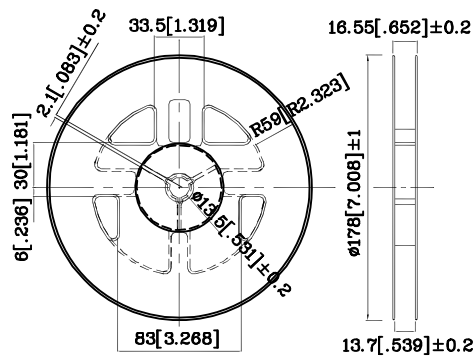

❖ Tape Specification (Units : mm)

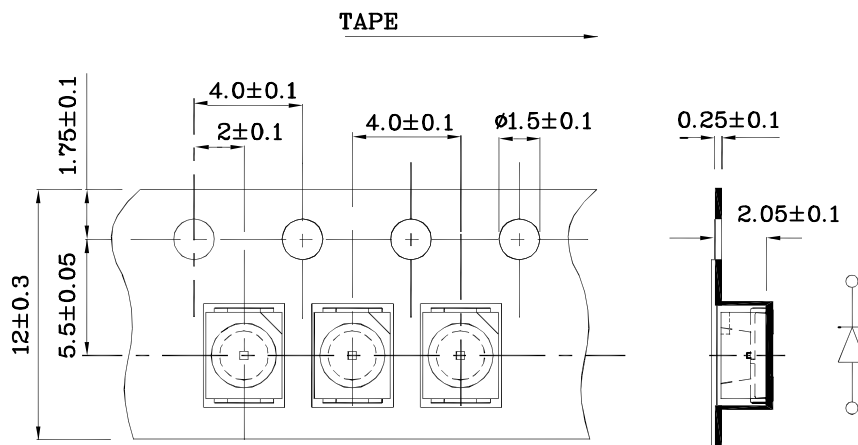

Remarks:



If special sorting is required (e.g. binning based on forward voltage, luminous intensity/ luminous flux or chromaticity), the typical accuracy of the sorting process is as follows:



1. Measurement tolerance of the chromaticity coordinates is ± 0.01 .
2. Luminous Intensity/ Luminous Flux: $\pm 15\%$
3. Forward Voltage: $\pm 0.1V$

Note: Accuracy may depend on the sorting parameters.

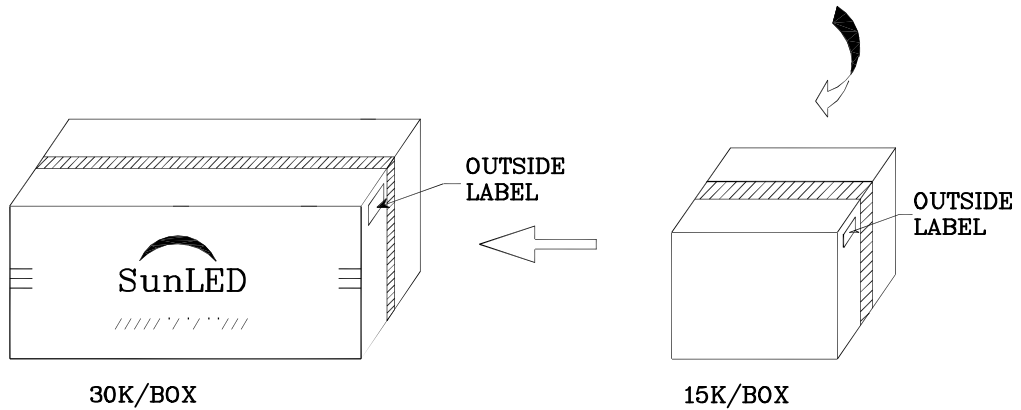
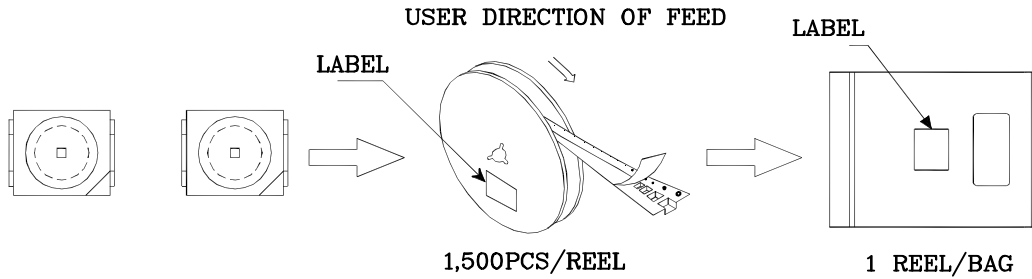

PACKING & LABEL SPECIFICATIONS

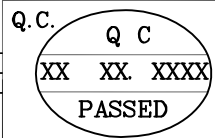
	
P/NO : XZxxx45x	
QTY : 1,500 pcs	CODE: XXX
S/N : XX	
LOT NO:	
 XXXXXXXXXXXXXXXXXXXXXXXX	
RoHS Compliant	