

Features

- PRE-TRIMMED LEADS FOR PC MOUNTING.
- I.C. COMPATIBLE.
- BLACK CASE ENHANCES CONTRAST RATIO.
- WIDE VIEWING ANGLE.
- HIGH RELIABILITY - LIFE MEASURED IN YEARS.
- UL RATING : 94V-0.
- HOUSING MATERIAL: TYPE 66 NYLON.
- RoHS COMPLIANT.

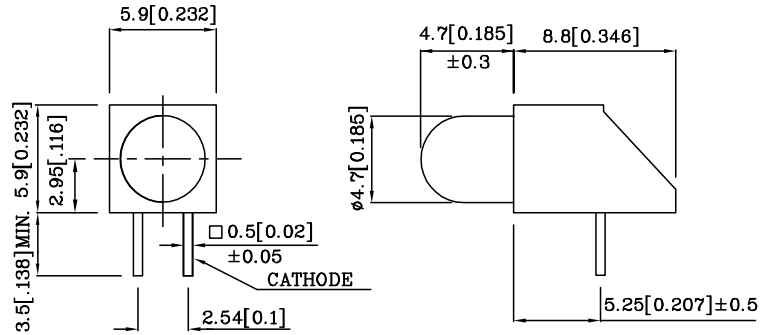

Notes:

1. All dimensions are in millimeters (inches).
2. Tolerance is $\pm 0.25(0.01)$ unless otherwise noted.

| Absolute Maximum Ratings (TA=25°C) | | UY (GaAsP/GaP) | Unit |
|--|---------------------|-------------------|------|
| Reverse Voltage | V _R | 5 | V |
| Forward Current | I _F | 30 | mA |
| Forward Current (Peak) 1/10 Duty Cycle 0.1ms Pulse Width | i _{FS} | 140 | mA |
| Power Dissipation | P _T | 105 | mW |
| Operating Temperature | T _A | -40 ~ +85 | °C |
| Storage Temperature | T _{stg} | -40 ~ +85 | |
| Lead Solder Temperature [2mm Below Package Base] | 260°C For 3 Seconds | | |
| Lead Solder Temperature [5mm Below Package Base] | 260°C For 5 Seconds | | |

| Operating Characteristics (TA=25°C) | | UY (GaAsP/GaP) | Unit |
|---|----------------|-------------------|------|
| Forward Voltage (Typ.) (I _F =10mA) | V _F | 1.95 | V |
| Forward Voltage (Max.) (I _F =10mA) | V _F | 2.5 | V |
| Reverse Current (V _R =5V) | I _R | 10 | uA |
| Wavelength of Peak Emission (I _F =10mA) | λ _P | 590 | nm |
| Wavelength of Dominant Emission (I _F =10mA) | λ _D | 588 | nm |
| Spectral Line Full Width At Half-Maximum (I _F =10mA) | Δλ | 35 | nm |
| Capacitance (V _F =0V, f=1MHz) | C | 20 | pF |

| Part Number | Emitting Color | Emitting Material | Lens-color | Luminous Intensity (I _F =10mA) mcd | | Wavelength nm λ _P | Viewing Angle 2θ 1/2 |
|---|----------------|-------------------|-----------------|---|------|------------------------------------|-------------------------|
| | | | | min. | typ. | | |
| XVR1LUY69D | Yellow | GaAsP/GaP | Yellow Diffused | 5 | 17 | 590 | 60° |
| Published Date : MAY 30,2005 Drawing No : XDSA2825 V3 Checked : B.L.LIU P.1/3 | | | | | | | |

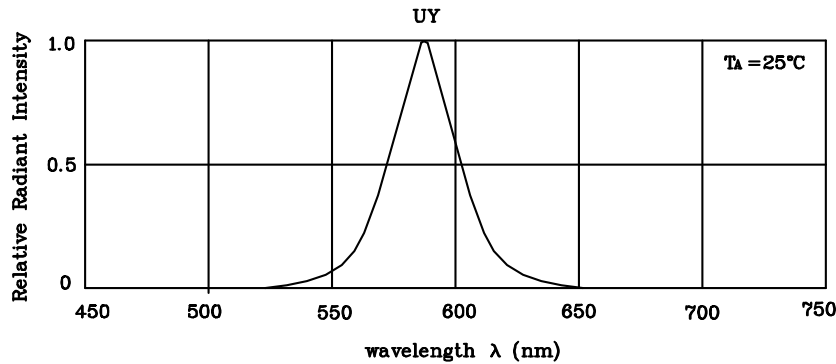

RELATIVE INTENSITY Vs. WAVELENGTH

❖ UY

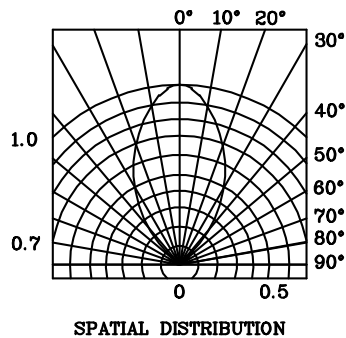
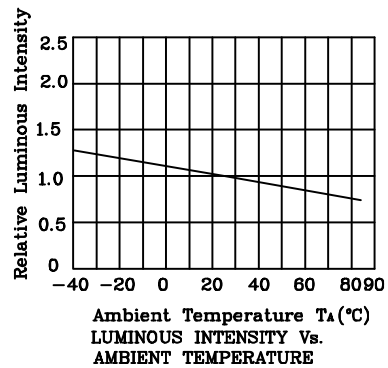
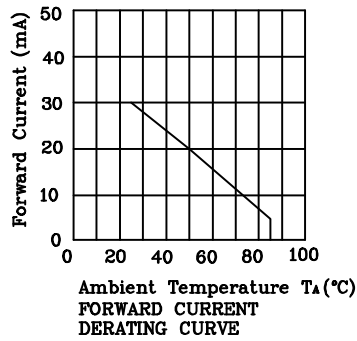
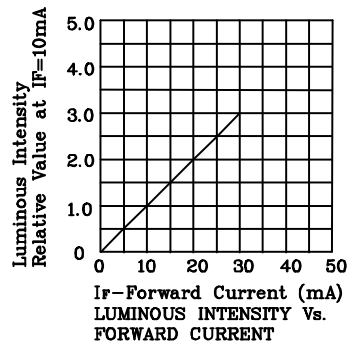
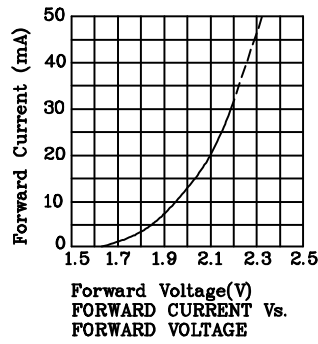

Wave Soldering Profile For Lead-free Through-hole LED.

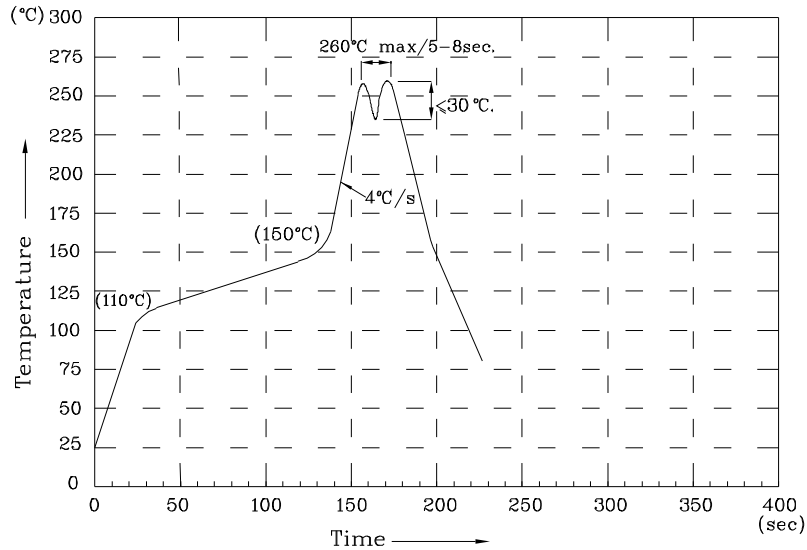

NOTES:

- 1.Recommend the wave temperature 245°C~260°C.The maximum soldering temperature should be less than 260°C.
- 2.Do not apply stress on epoxy resins when temperature is over 85 degree°C.
- 3.The soldering profile apply to the lead free soldering (Sn/Cu/Ag alloy).
- 4.No more than once.

Remarks:

If special sorting is required (e.g. binning based on forward voltage, luminous intensity, or wavelength), the typical accuracy of the sorting process is as follows:

1. Wavelength: +/-1nm
2. Luminous Intensity: +/-15%
3. Forward Voltage: +/-0.1V

Note: Accuracy may depend on the sorting parameters.