

Features

- PRE-TRIMMED LEADS FOR PC BOARD MOUNTING.
- 3 LEADS WITH COMMON CATHODE LEAD.
- THIRD COLOR (MIXED COLOR) AVAILABLE.
- I.C. COMPATIBLE.
- BLACK CASE ENHANCES CONTRAST RATIO.
- WIDE VIEWING ANGLE.
- HIGH RELIABILITY - LIFE MEASURED IN YEARS.
- UL RATING : 94V-0.
- HOUSING MATERIAL: TYPE 66 NYLON.
- RoHS COMPLIANT.

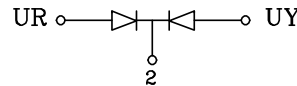
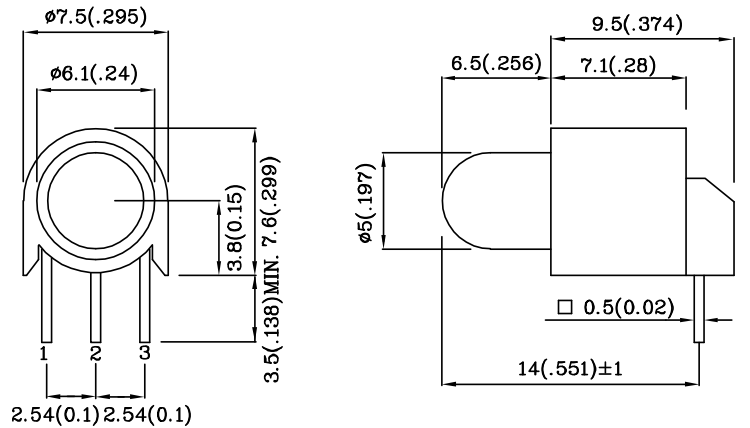

- 1 ANODE RED
- 2 COMMON CATHODE
- 3 ANODE YELLOW

Notes:

1. All dimensions are in millimeters (inches).
2. Tolerance is $\pm 0.25(0.01)$ unless otherwise noted.

Absolute Maximum Ratings (TA=25°C)		UR (GaAsP/ GaP)	UY (GaAsP/ GaP)	Unit
Reverse Voltage	VR	5	5	V
Forward Current	IF	30	30	mA
Forward Current (peak) 1/10Duty Cycle 0.1ms Pulse Width	iFS	160	140	mA
Power Dissipation	PT	105	105	mW
Operating Temperature	TA	-40 ~ +85		°C
Storage Temperature	Tstg	-40 ~ +85		
Lead Solder Temperature [2mm below package base]	260°C For 3 Seconds			
Lead Solder Temperature [5mm below package base]	260°C For 5 Seconds			

Operating Characteristics (TA=25°C)		UR (GaAsP/ GaP)	UY (GaAsP/ GaP)	Unit
Forward Voltage (typ.) (IF=20mA)	VF	2.0	2.1	V
Forward Voltage (max.) (IF=20mA)	VF	2.5	2.5	V
Reverse Current (VR=5V)	IR	10	10	uA
Wavelength of Peak Emission (IF=20mA)	λP	627	590	nm
Wavelength of Dominant Emission (IF=20mA)	λD	625	588	nm
Spectral Line Full Width At Half-Maximum (IF=20mA)	$\Delta\lambda$	45	35	nm
Capacitance (VF=0V, f=1MHz)	C	15	20	pF

Part Number	Emitting Color	Emitting Material	Lens-color	Luminous Intensity (IF=20mA) mcd		Wavelength nm λP	Viewing Angle 2 θ 1/2
				min.	typ.		
XVB1LUYR59M	Red	GaAsP/GaP	White Diffused	18	59	627	60°
	Yellow	GaAsP/GaP		18	39	590	60°

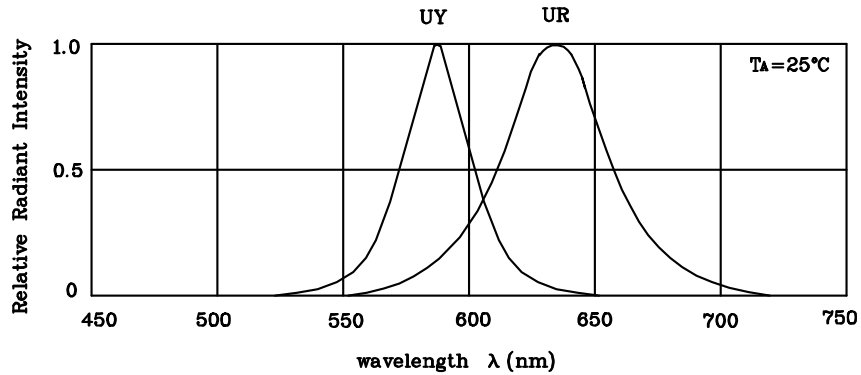

RELATIVE INTENSITY Vs. WAVELENGTH

❖ UR

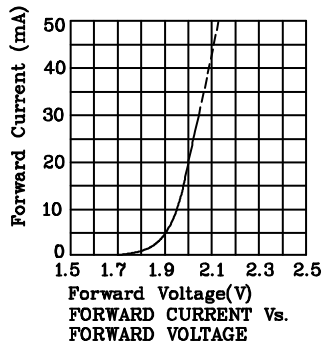

FORWARD CURRENT Vs. FORWARD VOLTAGE

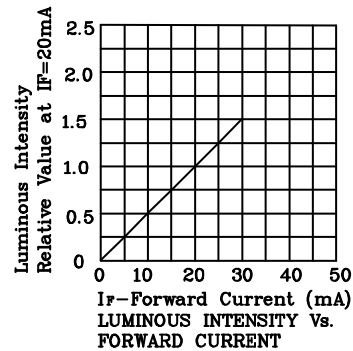

LUMINOUS INTENSITY Vs. FORWARD CURRENT

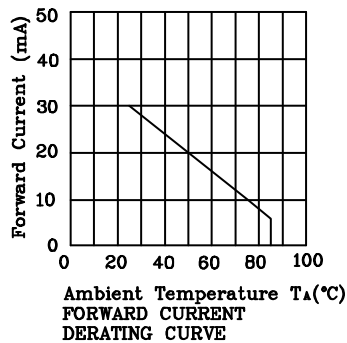

FORWARD CURRENT DERATING CURVE

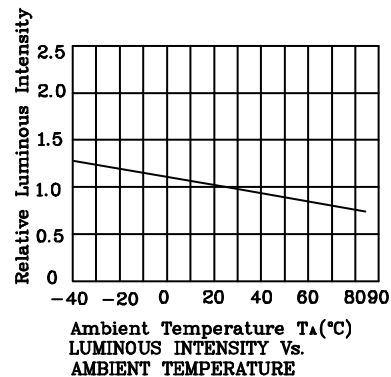

LUMINOUS INTENSITY Vs. AMBIENT TEMPERATURE

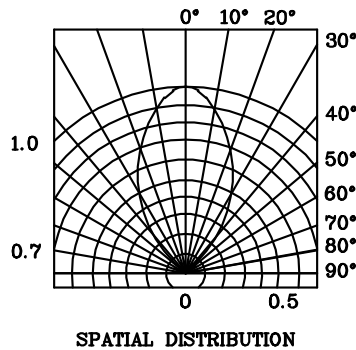

SPATIAL DISTRIBUTION

❖ UY

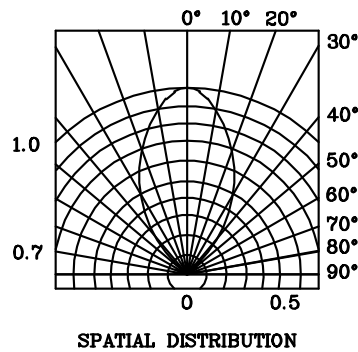
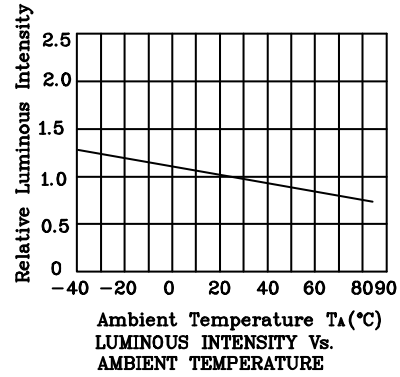
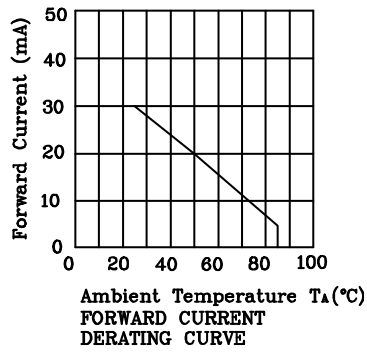
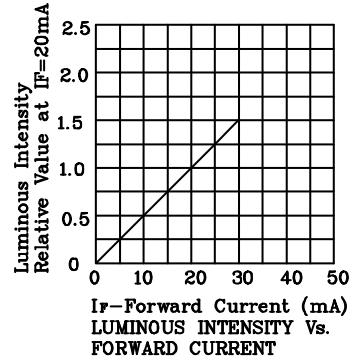
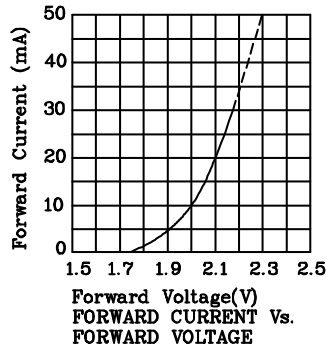

Wave Soldering Profile For Lead-free Through-hole LED.

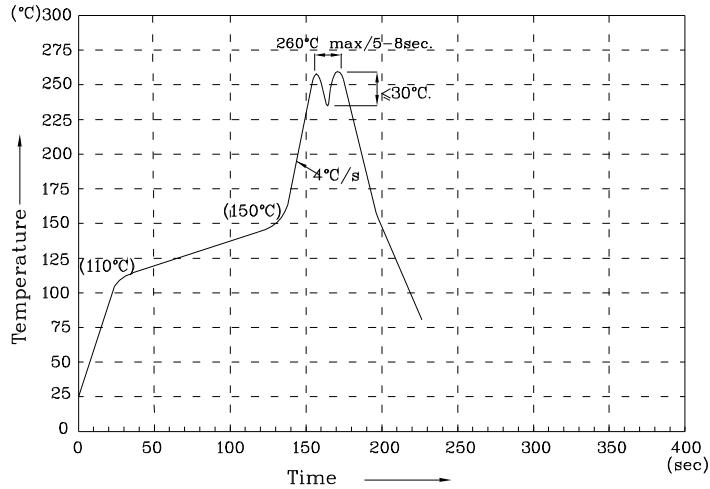

NOTES:

1. Recommend the wave temperature 245°C~260°C. The maximum soldering temperature should be less than 260°C.
2. Do not apply stress on epoxy resins when temperature is over 85 degree°C.
3. The soldering profile apply to the lead free soldering (Sn/Cu/Ag alloy).
4. No more than once.

Remarks:

If special sorting is required (e.g. binning based on forward voltage, luminous intensity, or wavelength), the typical accuracy of the sorting process is as follows:

1. Wavelength: +/-1nm
2. Luminous Intensity: +/-15%
3. Forward Voltage: +/-0.1V

Note: Accuracy may depend on the sorting parameters.