

Features

- PRE-TRIMMED LEADS FOR PC BOARD MOUNTING.
- 3 LEADS WITH COMMON CATHODE LEAD.
- THIRD COLOR (MIXED COLOR) AVAILABLE.
- I.C. COMPATIBLE.
- BLACK CASE ENHANCES CONTRAST RATIO.
- WIDE VIEWING ANGLE.
- HIGH RELIABILITY - LIFE MEASURED IN YEARS.
- UL RATING : 94V-0.
- HOUSING MATERIAL: TYPE 66 NYLON.
- RoHS COMPLIANT.

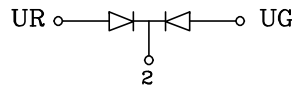
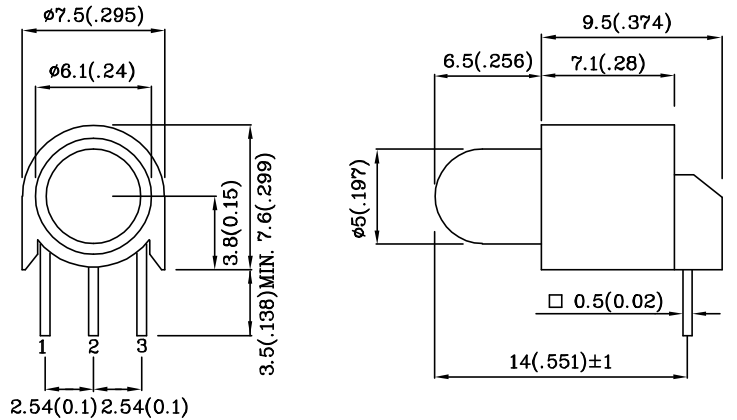

- 1 ANODE RED
- 2 COMMON CATHODE
- 3 ANODE GREEN

Notes:

- 1. All dimensions are in millimeters (inches).
- 2. Tolerance is $\pm 0.25(0.01)$ " unless otherwise noted.

Absolute Maximum Ratings ($T_A=25^\circ\text{C}$)		UR (GaAsP/ GaP)	UG (GaP)	Unit
Reverse Voltage	V_R	5	5	V
Forward Current	I_F	30	25	mA
Forward Current (peak) 1/10Duty Cycle 0.1ms Pulse Width	i_{FS}	160	140	mA
Power Dissipation	P_T	105	105	mW
Operating Temperature	T_A	-40 ~ +85		°C
Storage Temperature	T_{stg}	-40 ~ +85		
Lead Solder Temperature [2mm below package base]	260°C For 3 Seconds			
Lead Solder Temperature [5mm below package base]	260°C For 5 Seconds			

Operating Characteristics ($T_A=25^\circ\text{C}$)		UR (GaAsP/ GaP)	UG (GaP)	Unit
Forward Voltage (typ.) ($I_F=20\text{mA}$)	V_F	2.0	2.2	V
Forward Voltage (max.) ($I_F=20\text{mA}$)	V_F	2.5	2.5	V
Reverse Current ($V_R=5\text{V}$)	I_R	10	10	μA
Wavelength of Peak Emission ($I_F=20\text{mA}$)	λ_P	627	565	nm
Wavelength of Dominant Emission ($I_F=20\text{mA}$)	λ_D	625	568	nm
Spectral Line Full Width At Half-Maximum ($I_F=20\text{mA}$)	$\Delta\lambda$	45	30	nm
Capacitance ($V_F=0\text{V}$, $f=1\text{MHz}$)	C	15	15	pF

Part Number	Emitting Color	Emitting Material	Lens-color	Luminous Intensity ($I_F=20\text{mA}$) mcd		Wavelength nm λ_P	Viewing Angle 2θ 1/2
				min.	typ.		
XVB1LUGR59M	Red	GaAsP/GaP	White Diffused	18	59	627	60°
	Green	GaP		18	49	565	60°
Published Date : MAY 25, 2005							
Drawing No : XDSA2862							
V3							
Checked : B.L.LIU							
P.1/4							

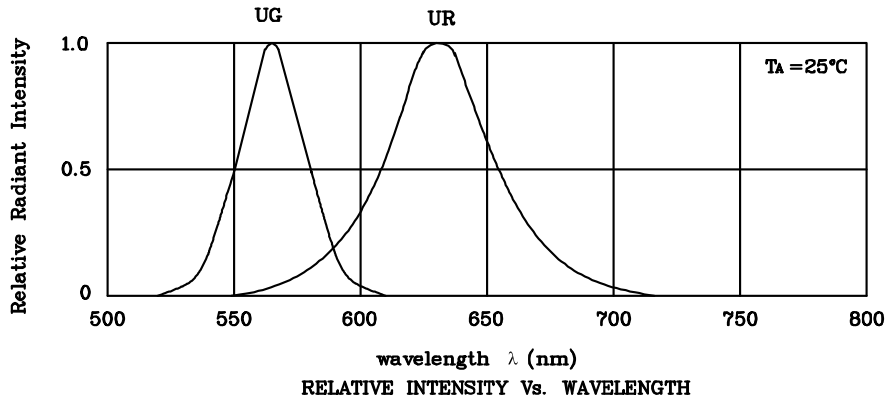

❖ UR

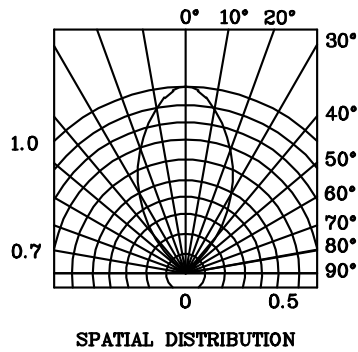
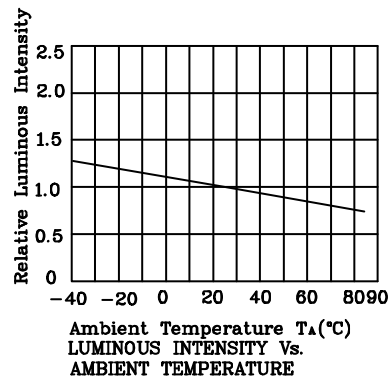
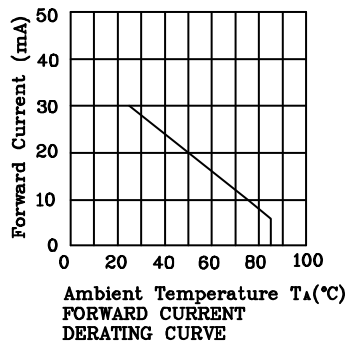
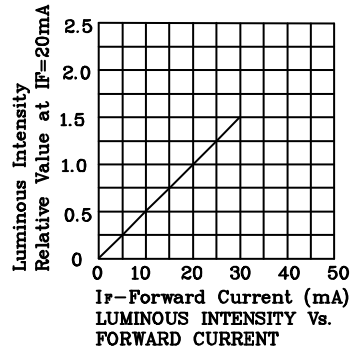
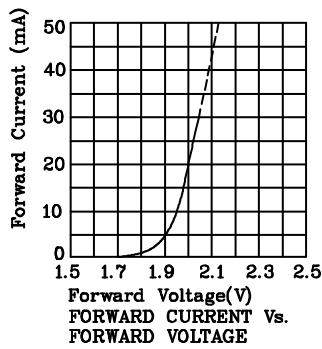

❖ UG

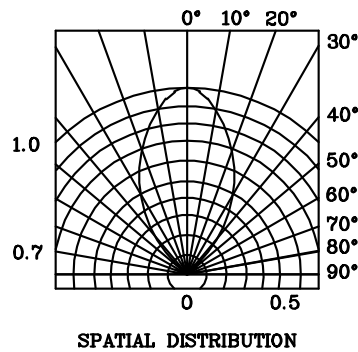
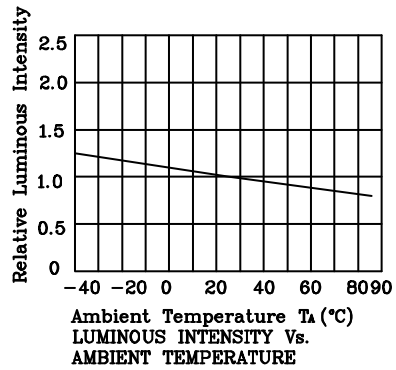
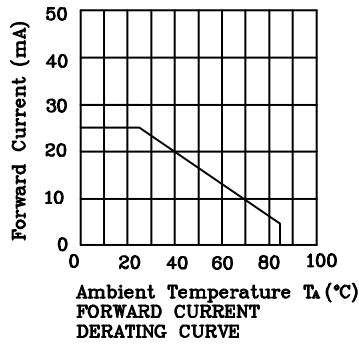
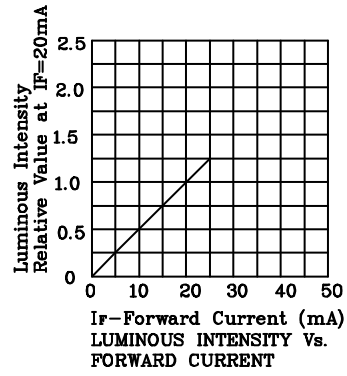
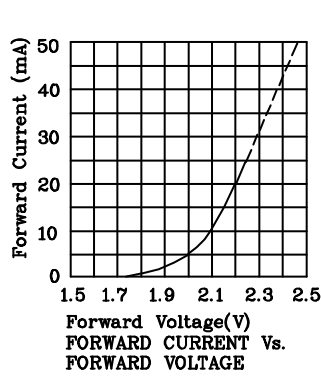

Wave Soldering Profile For Lead-free Through-hole LED.

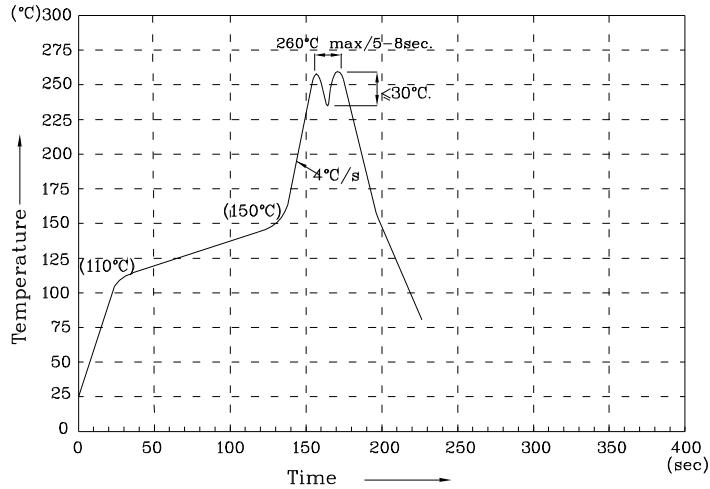

NOTES:

1. Recommend the wave temperature 245°C~260°C. The maximum soldering temperature should be less than 260°C.
2. Do not apply stress on epoxy resins when temperature is over 85 degree°C.
3. The soldering profile apply to the lead free soldering (Sn/Cu/Ag alloy).
4. No more than once.

Remarks:

If special sorting is required (e.g. binning based on forward voltage, luminous intensity, or wavelength), the typical accuracy of the sorting process is as follows:

1. Wavelength: +/-1nm
2. Luminous Intensity: +/-15%
3. Forward Voltage: +/-0.1V

Note: Accuracy may depend on the sorting parameters.