

Features

- I.C. COMPATIBLE
- BLACK CASE ENHANCES CONTRAST RATIO
- HOUSING MATERIAL: PPA
- HIGH TEMPERATURE RESISTANT HOUSING
- PACKAGE: 500PCS / REEL .
- RoHS COMPLIANT.

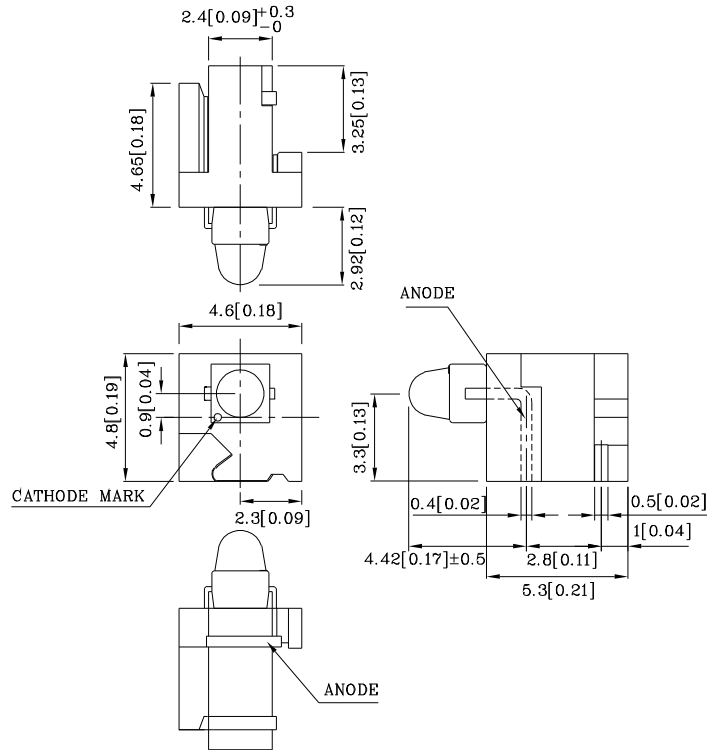

Notes:

1. All dimensions are in millimeters (inches).
2. Tolerance is ± 0.1(0.004") unless otherwise noted.

Absolute maximum ratings (TA=25°C)		UY (GaAsP/GaP)	Unit
Reverse Voltage	V _R	5	V
Forward Current	I _F	30	mA
Forward Current (Peak) 1/10 Duty Cycle 0.1ms Pulse Width	i _{FS}	140	mA
Power Dissipation	P _T	105	mW
Operating Temperature	T _A	-40 ~ +85	°C
Storage Temperature	T _{stg}	-40 ~ +85	

Operating Characteristics (TA=25°C)		UY (GaAsP/GaP)	Unit
Forward Voltage (Typ.) (I _F =20mA)	V _F	2.1	V
Forward Voltage (Max.) (I _F =20mA)	V _F	2.5	V
Reverse Current (V _R =5V)	I _R	10	uA
Wavelength of Peak Emission (I _F =20mA)	λ _p	590	nm
Wavelength of Dominant Emission (I _F =20mA)	λ _D	588	nm
Spectral Line Full Width At Half-Maximum (I _F =20mA)	Δλ	35	nm
Capacitance (V _F =0V, f=1MHz)	C	20	pF

Part Number	Emitting Color	Emitting Material	Lens-color	Luminous Intensity (I _F =20mA) mcd		Wavelength nm λ _P	Viewing Angle 2 θ 1/2
				min.	typ.		
XRP1LUY103D	Yellow	GaAsP/GaP	Yellow Diffused	2.6	9	590	40°

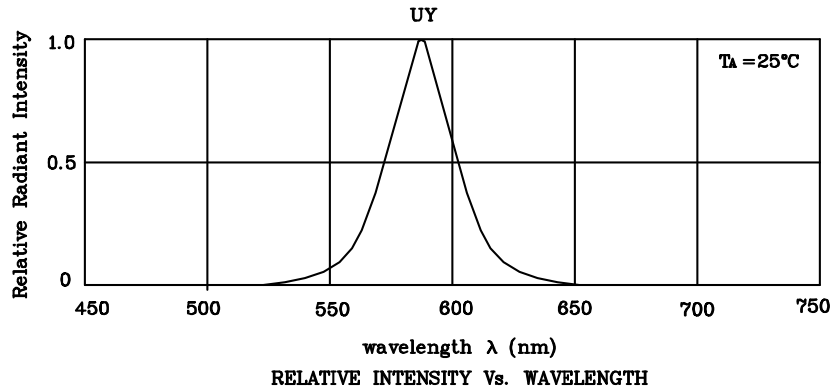

❖ UY

