

Features

- BLACK CASE ENHANCES CONTRAST.
- VIBRATION AND SHOCK RESISTANT.
- UL RATING : 94V-0.
- HOUSING MATERIAL: TYPE 66 NYLON.
- 5V INTERNAL RESISTOR.
- RoHS COMPLIANT.

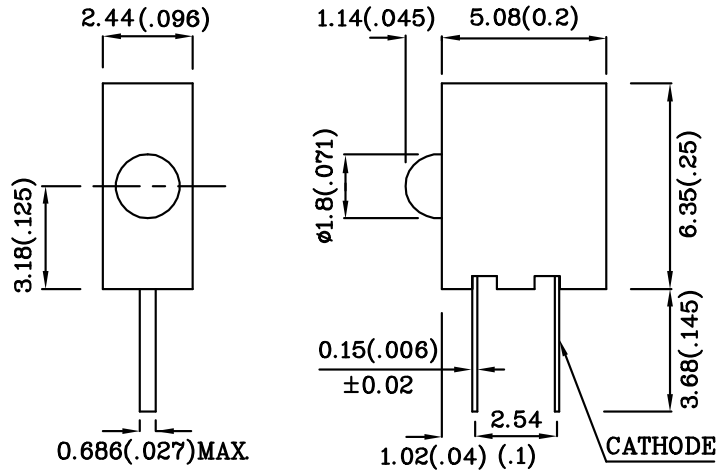

Notes:

1. All dimensions are in millimeters (inches).
2. Tolerance is $\pm 0.25(0.01)$ " unless otherwise noted.

Absolute maximum ratings (TA=25°C)		UY (GaAsP/ GaP)	Unit
Reverse Voltage	V _R	5	V
Forward Voltage	V _F	6	V
Power Dissipation	P _T	85	mW
Operating Temperature	T _A	-40 ~ +70	°C
Storage Temperature	T _{stg}	-40 ~ +85	
Lead Solder Temperature [2mm Below Package Base]	260°C For 3 Seconds		
Lead Solder Temperature [5mm Below Package Base]	260°C For 5 Seconds		

Operating Characteristics (TA=25°C)		UY (GaAsP/ GaP)	Unit
Forward Current (Typ.) (V _F =5V)	I _F	13	mA
Forward Current (Max.) (V _F =5V)	I _F	17.5	mA
Reverse Current (V _R =5V)	I _R	10	uA
Wavelength of Peak Emission (V _F =5V)	λ P	590	nm
Wavelength of Dominant Emission (V _F =5V)	λ D	588	nm
Spectral Line Full Width At Half-Maximum (V _F =5V)	$\Delta\lambda$	35	nm

Part Number	Emitting Color	Emitting Material	Lens-color	Luminous Intensity (V=5V) mcd		Wavelength nm λ P	Viewing Angle 2 θ 1/2
				min.	typ.		
XNH1ZUY46D5V	Yellow	GaAsP/GaP	Yellow Diffused	1.0	2.8	590	40°
Published Date : MAY 29,2005 Drawing No : XDSA2716 V3 Checked : B.L.LIU P.1/3							

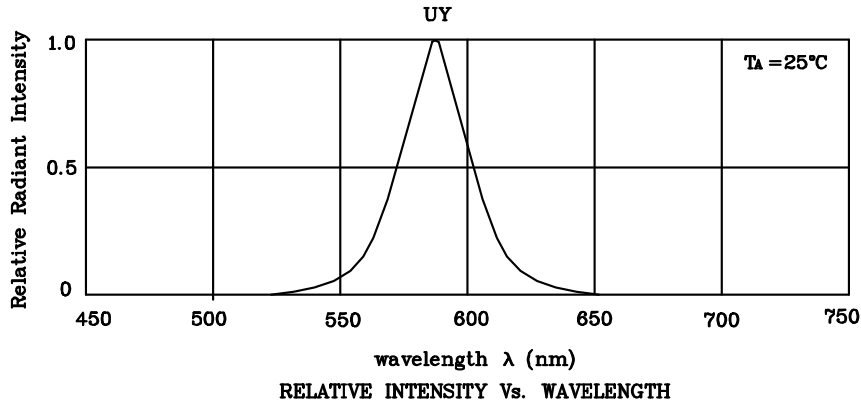

❖ UY

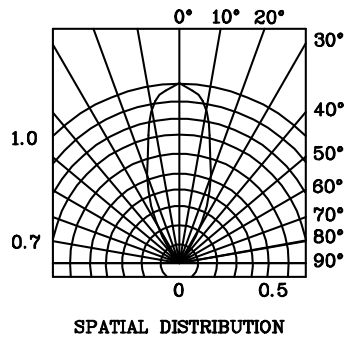
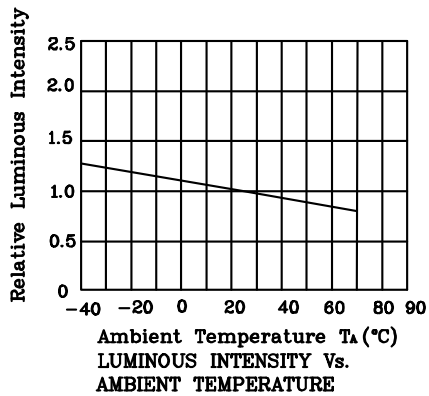
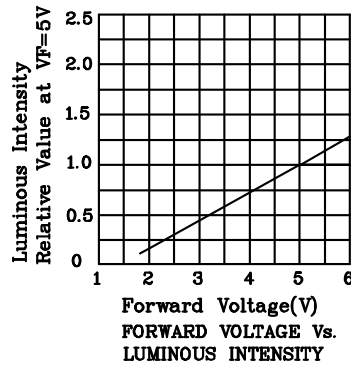
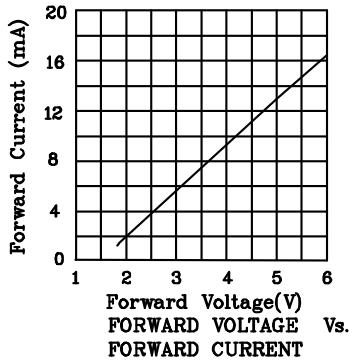

Remarks:

If special sorting is required (e.g. binning based on luminous intensity or wavelength), the typical accuracy of the sorting process is as follows:

1. Wavelength: +/-1nm
2. Luminous Intensity: +/-15%

Note: Accuracy may depend on the sorting parameters.

XNH1ZUY46D5V

Wave Soldering Profile For Lead-free Through-hole LED.

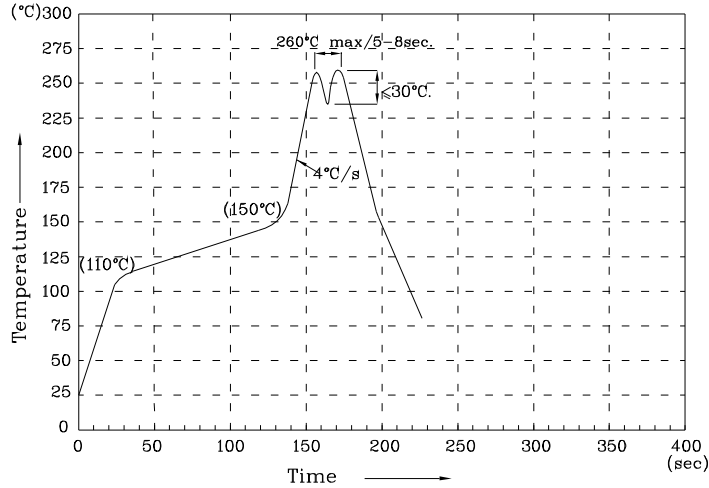

NOTES:

1. Recommend the wave temperature 245°C~260°C. The maximum soldering temperature should be less than 260°C.
2. Do not apply stress on epoxy resins when temperature is over 85 degree°C.
3. The soldering profile apply to the lead free soldering (Sn/Cu/Ag alloy).
4. No more than once.