

**Features**

- LOW POWER CONSUMPTION.
- I.C. COMPATIBLE.
- LONG LIFE - SOLID STATE RELIABILITY.
- RoHS COMPLIANT.

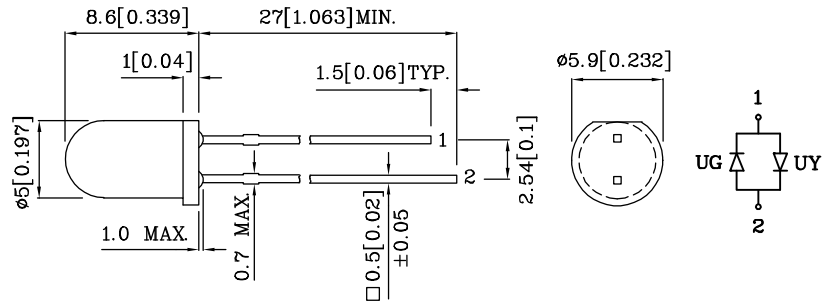

Notes:

1. All dimensions are in millimeters (inches).
2. Tolerance is  $\pm 0.25(0.01)$  unless otherwise noted.

Absolute maximum ratings ( $T_A=25^\circ\text{C}$ )		UG (GaP)	UY (GaAsP/ GaP)	Unit
Forward Current	$I_F$	25	30	mA
Forward Current (Peak) 1/10 Duty Cycle 0.1ms Pulse Width	$i_{FS}$	140	140	mA
Power Dissipation	$P_T$	105	105	mW
Operating Temperature	$T_A$	-40 ~ +85		°C
Storage Temperature	$T_{stg}$	-40 ~ +85		
Lead Solder Temperature [2mm Below Package Base]	260°C For 3 Seconds			
Lead Solder Temperature [5mm Below Package Base]	260°C For 5 Seconds			

Operating Characteristics ( $T_A=25^\circ\text{C}$ )		UG (GaP)	UY (GaAsP /GaP)	Unit
Forward Voltage (Typ.) ( $I_F=20\text{mA}$ )	$V_F$	2.2	2.1	V
Forward Voltage (Max.) ( $I_F=20\text{mA}$ )	$V_F$	2.5	2.5	V
Wavelength of Peak Emission ( $I_F=20\text{mA}$ )	$\lambda_P$	565	590	nm
Wavelength of Dominant Emission ( $I_F=20\text{mA}$ )	$\lambda_D$	568	588	nm
Spectral Line Full Width At Half-Maximum ( $I_F=20\text{mA}$ )	$\Delta\lambda$	30	35	nm
Capacitance ( $V_F=0\text{V}$ , $f=1\text{MHz}$ )	$C$	15	20	pF

Part Number	Emitting Color	Emitting Material	Lens-color	Luminous Intensity ( $I_F=20\text{mA}$ ) mcd		Wavelength nm $\lambda_P$	Viewing Angle $2\theta$ 1/2
				min.	typ.		
XLUGY58M	Green	GaP	White Diffused	10	19	565	60°
	Yellow	GaAsP/GaP		4	9	590	

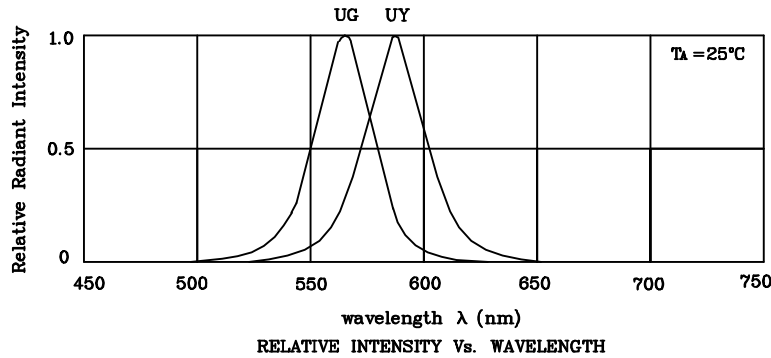

❖ UG

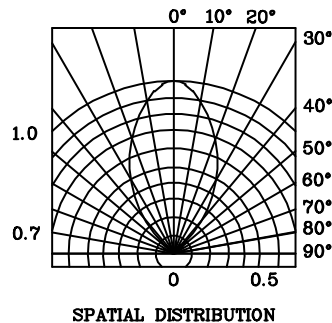
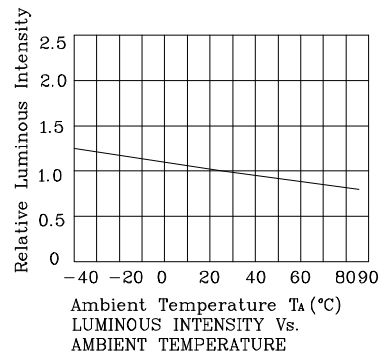
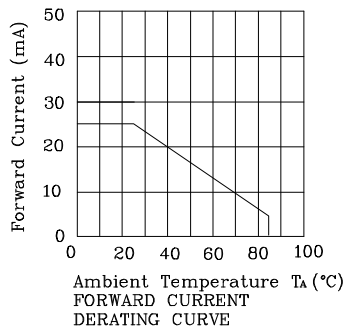
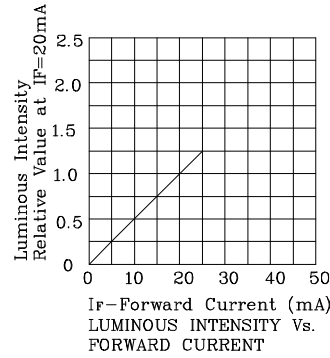
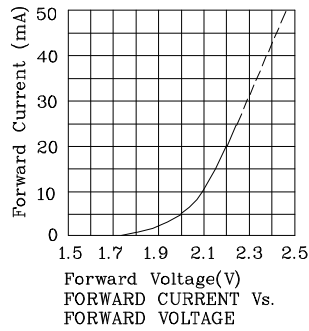

❖ UY

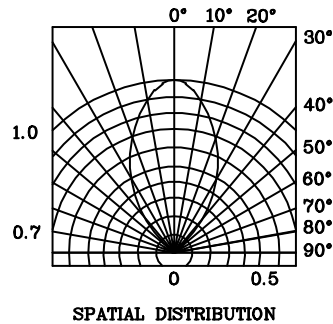
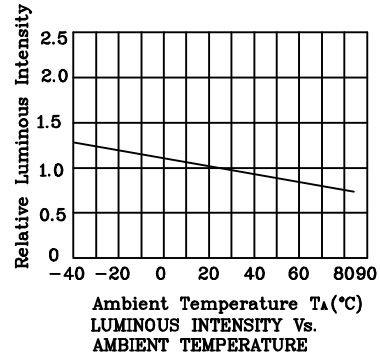
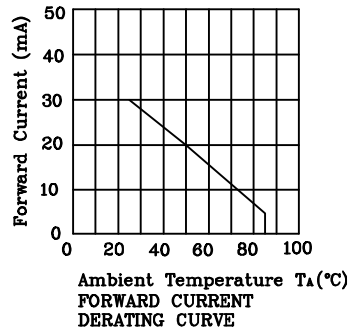
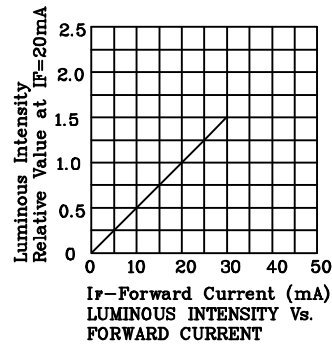
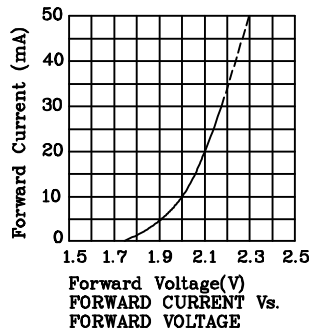

Remarks:

If special sorting is required (e.g. binning based on forward voltage, luminous intensity or wavelength), the typical accuracy of the sorting process is as follows:

1. Wavelength: +/-1nm
2. Luminous Intensity: +/-15%
3. Forward Voltage: +/-0.1V

Note: Accuracy may depend on the sorting parameters.

**XLUGY58M**

Wave Soldering Profile For Lead-free Through-hole LED.

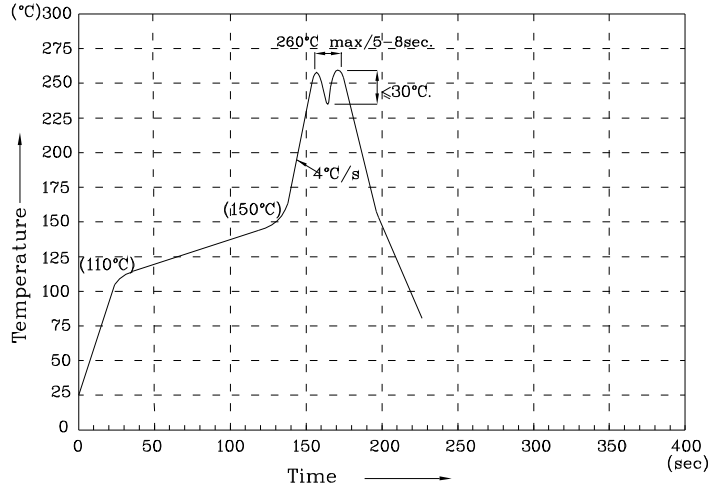

NOTES:

1. Recommend the wave temperature 245°C~260°C. The maximum soldering temperature should be less than 260°C.
2. Do not apply stress on epoxy resins when temperature is over 85 degree°C.
3. The soldering profile apply to the lead free soldering (Sn/Cu/Ag alloy).
4. No more than once.