

Features

- 12 PINS.
- HIGH LUMINOUS INTENSITY.
- LOW POWER CONSUMPTION.
- WIDE VIEWING ANGLE.
- CATEGORIZED FOR LUMINOUS INTENSITY.
- EXCELLENT ON/OFF CONTRAST.
- EASY MOUNTING ON P.C. BOARD OR SOCKETS.
- SOLID STATE RELIABILITY.
- RoHS COMPLIANT.

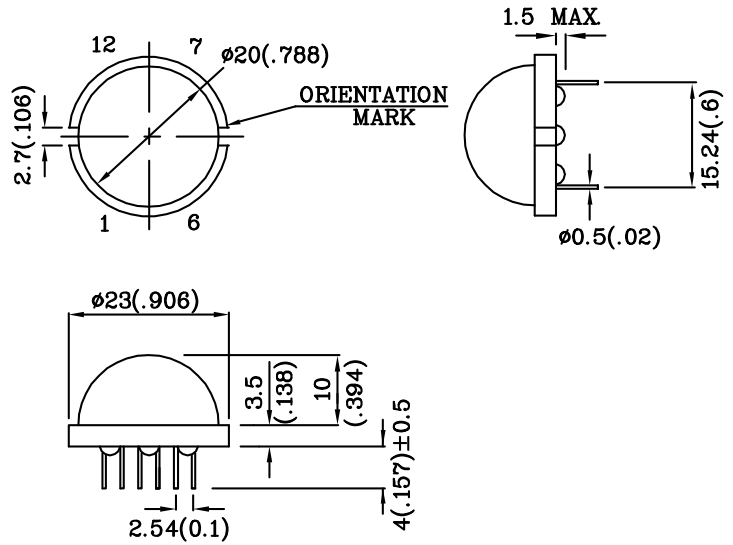
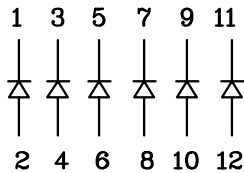

Notes:

1. All dimensions are in millimeters (inches).
2. Tolerance is ± 0.25(0.01") unless otherwise noted.

Absolute Maximum Ratings (TA=25°C)		MG (GaP)	Unit
Reverse Voltage	VR	5	V
Forward Current	IF	25	mA
Forward Current (peak) 1/10 Duty Cycle 0.1ms Pulse Width	iFS	140	mA
Power Dissipation	PT	105	mW
Operating Temperature	TA	-40 ~ +85	°C
Storage Temperature	Tstg	-40 ~ +85	
Lead Solder Temperature [2mm below package base]	260°C For 3 Seconds		
Lead Solder Temperature [5mm below package base]	260°C For 5 Seconds		

Operating Characteristics (TA=25°C)		MG (GaP)	Unit
Forward Voltage (typ.) (IF=20mA)	VF	2.2	V
Forward Voltage (max.) (IF=20mA)	VF	2.5	V
Reverse Current (VR=5V)	IR	10	uA
Wavelength of Peak Emission (IF=20mA)	λ P	565	nm
Wavelength of Dominant Emission (IF=20mA)	λ D	568	nm
Spectral Line Full Width At Half-Maximum (IF=20mA)	Δλ	30	nm
Capacitance (VF=0V, f=1MHz)	C	15	pF

Part Number	Emitting Color	Emitting Material	Lens-color	Luminous Intensity (IF=20mA) mcd		Wavelength nm λ P	Viewing Angle 2 θ 1/2
				min.	typ.		
XFMG20D6C	Green	GaP	Green Diffused	70	198	565	120°
Published Date : JUN 01,2005 Drawing No :XDSA2073 V3 Checked : Shin Chi P.1/3							

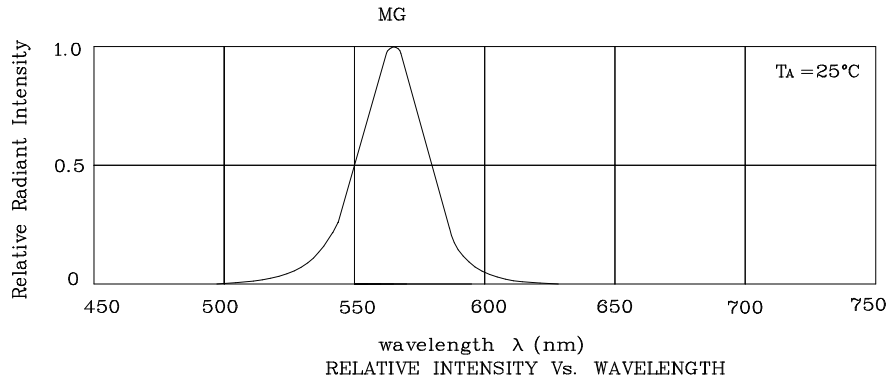

❖ MG

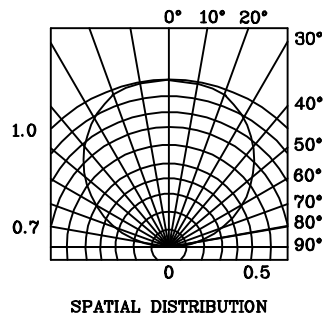
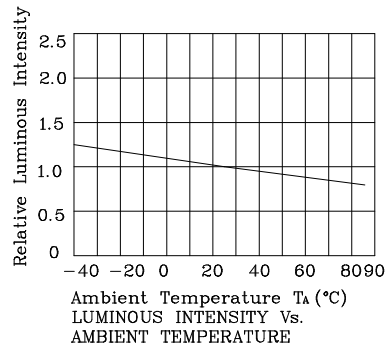
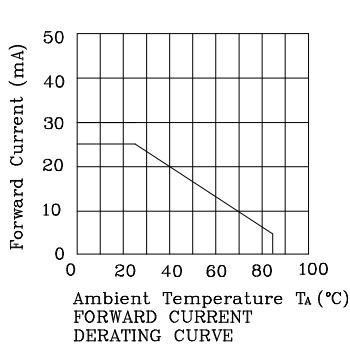
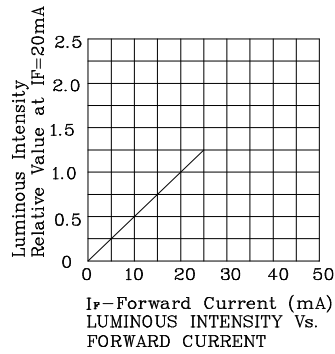
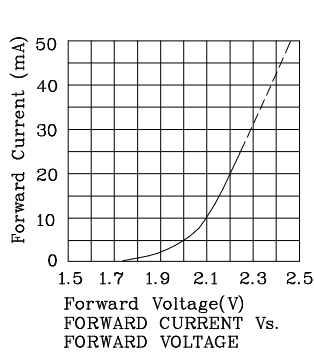

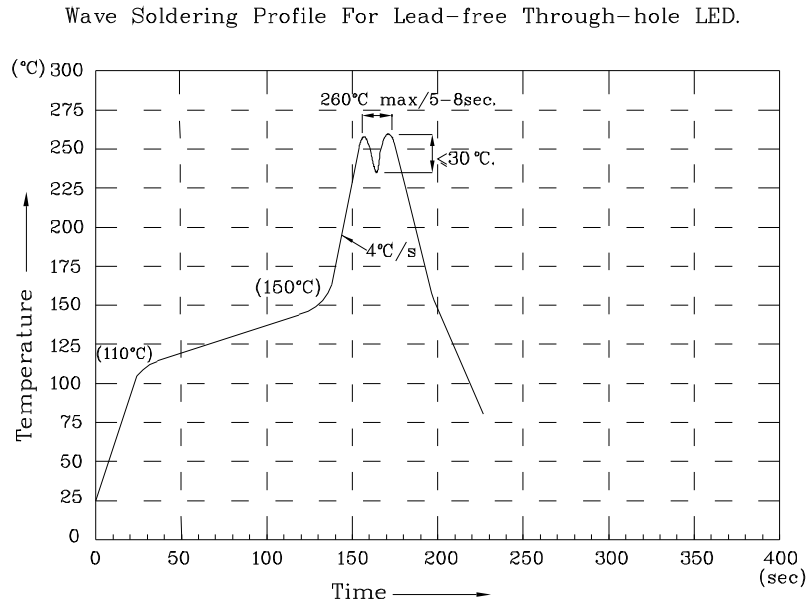

NOTES:

- 1.Recommend the wave temperature 245°C~260°C.The maximum soldering temperature should be less than 260°C.
- 2.Do not apply stress on epoxy resins when temperature is over 85 degree°C.
- 3.The soldering profile apply to the lead free soldering (Sn/Cu/Ag alloy).
- 4.No more than once.

Remarks:

If special sorting is required (e.g. binning based on forward voltage, luminous intensity, or wavelength), the typical accuracy of the sorting process is as follows:

1. Wavelength: +/-1nm
2. Luminous Intensity: +/-15%
3. Forward Voltage: +/-0.1V

Note: Accuracy may depend on the sorting parameters.