

Features

- 0.54 INCH CHARACTER HEIGHT.
- LOW CURRENT OPERATION.
- HIGH CONTRAST AND LIGHT OUTPUT.
- EASY MOUNTING ON P.C. BOARDS OR SOCKETS.
- CATEGORIZED FOR LUMINOUS INTENSITY.
- MECHANICALLY RUGGED.
- STANDARD: GRAY FACE, WHITE SEGMENT.
- RoHS COMPLIANT.

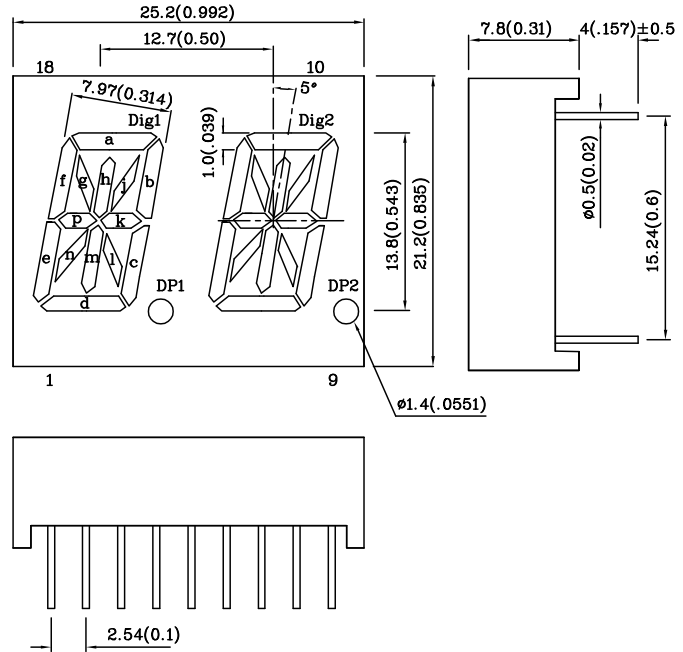
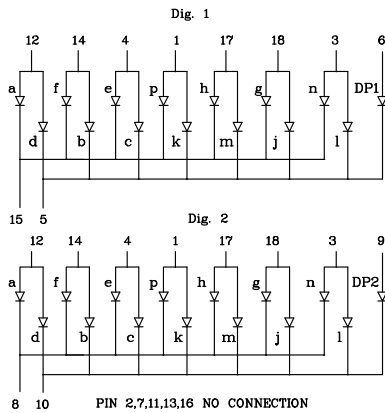

Notes:

1. All dimensions are in millimeters (inches).
2. Tolerance is $\pm 0.25(0.01)$ " unless otherwise noted.

Absolute maximum ratings ($T_A=25^\circ\text{C}$)		UG (GaP)	Unit
Reverse Voltage (Per Segment or DP)	V_R	5	V
Forward Current (Per Segment or DP)	I_F	25	mA
Forward Current (Peak) 1/10 Duty Cycle 0.1ms Pulse Width (Per Segment or DP)	i_{FS}	140	mA
Power Dissipation (Per Segment or DP)	P_T	105	mW
Operating Temperature	T_A	-40 ~ +85	°C
Storage Temperature	T_{stg}	-40 ~ +85	
Lead Solder Temperature [2mm Below Package Base]	260°C For 5 Seconds		

Operating Characteristics ($T_A=25^\circ\text{C}$)		UG (GaP)	Unit
Forward Voltage (Typ.) (Per Segment or DP) ($I_F=10\text{mA}$)	V_F	2.0	V
Forward Voltage (Max.) (Per Segment or DP) ($I_F=10\text{mA}$)	V_F	2.5	V
Reverse Current (Per Segment or DP) ($V_R=5\text{V}$)	I_R	10	μA
Wavelength of Peak Emission ($I_F=10\text{mA}$)	λ_P	565	nm
Wavelength of Dominant Emission ($I_F=10\text{mA}$)	λ_D	568	nm
Spectral Line Full Width At Half-Maximum ($I_F=10\text{mA}$)	$\Delta\lambda$	30	nm
Capacitance ($V_F=0\text{V}$, $f=1\text{MHz}$)	C	15	pF

Part Number	Emitting Color	Emitting Material	Luminous Intensity ($I_F=10\text{mA}$) ucd	Wavelength nm λ_P	Description	
			min.	typ.		
XAUG14A2-A	Green	GaP	1900	7990	565	Common Anode, Rt. Hand Decimal

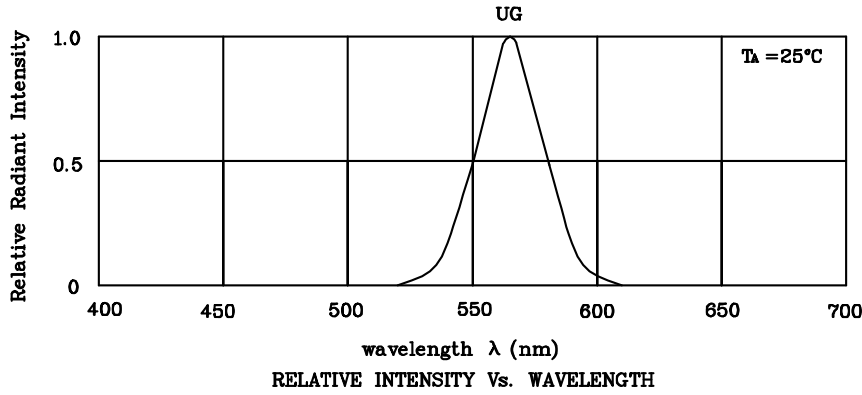

❖ UG

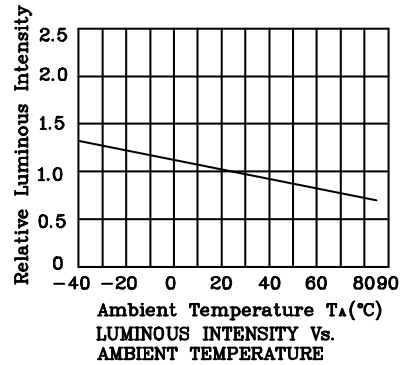
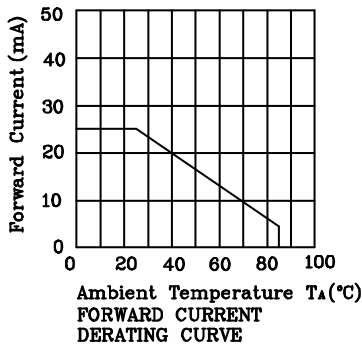
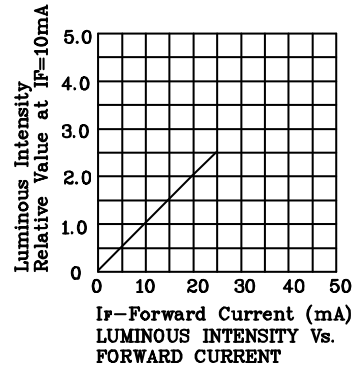
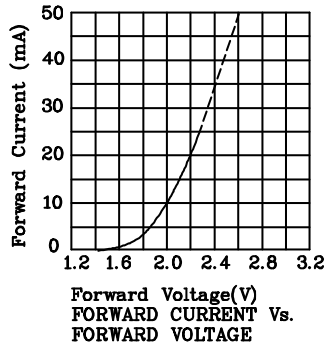

Remarks:

If special sorting is required (e.g. binning based on forward voltage, luminous intensity or wavelength), the typical accuracy of the sorting process is as follows:

1. Wavelength: +/-1nm
2. Luminous Intensity: +/-15%
3. Forward Voltage: +/-0.1V

Note: Accuracy may depend on the sorting parameters.

XAUG14A2-A

Wave Soldering Profile For Lead-free Through-hole LED.

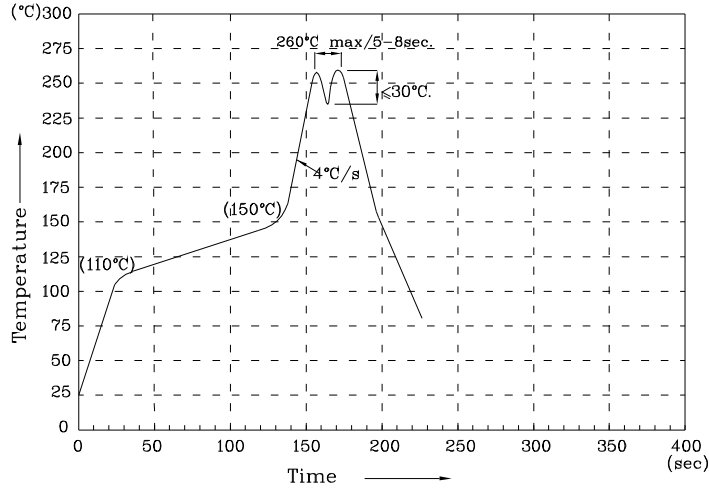

NOTES:

1. Recommend the wave temperature 245°C~260°C. The maximum soldering temperature should be less than 260°C.
2. Do not apply stress on epoxy resins when temperature is over 85 degree°C.
3. The soldering profile apply to the lead free soldering (Sn/Cu/Ag alloy).
4. No more than once.