

SPECIFICATION

Part No.	:	WS.01.B.305151
Product Name	:	Heavy Duty Screw Mount Antenna - Dual-Band 2.4~5.2GHz
Description	:	2.4GHz~5.2GHz suitable for ISM Bands/ZigBee/WLAN/Bluetooth IEEE.802.11/IEEE.802.15 UV and Vandal Resistant ABS Housing IP67 & IP69K Waterproof Rating 3M NFC-200 RP-SMA(M) – Standard RoHS Compliant



1. Introduction

WS.01 Hercules is a high efficiency, high gain thread mount dual band wireless antenna for external use on vehicles and outdoor assets worldwide. Omni-directional gain across both bands ensures constant reception and transmission making the WS.01 an ideal solution for a Zigbee Wireless Mesh for remote applications e.g. – remote metering.

It has been designed for heavy duty work with extra thick threads; with durable UV-resistant PVC housing is resistant to vandalism and direct attack. At only 29mm high it complies with the latest EU height restrictions directives for roof-mounted objects, whilst also enabling covert operation with a diameter of 49mm.

Many module manufacturers specify peak gain limits for any antennas that are to be connected to that module. Those peak gain limits are based on free-space conditions. In practice, the peak gain of an antenna tested in free-space can degrade by at least 1 or 2dBi when put inside a device. So ideally you should go for a slightly higher peak gain antenna than mentioned on the module specification to compensate for this effect, giving you better performance.

Upon testing of any of our antennas with your device and a selection of appropriate layout, integration technique, or cable, Taoglas can make sure any of our antennas' peak gain will be below the peak gain limits. Taoglas can then issue a specification and/or report for the selected antenna in your device that will clearly show it complying with the peak gain limits, so you can be assured you are meeting regulatory requirements for that module.

For example, a module manufacturer may state that the antenna must have less than 2dBi peak gain, but you don't need to select an embedded antenna that has a peak gain of less than 2dBi in free-space. This will give you a less optimized solution. It is better to go for a slightly higher free-space peak gain of 3dBi or more if available. Once that antenna gets integrated into your device, performance will degrade below this 2dBi peak gain due to the effects of GND plane, surrounding components, and device housing. If you want to be absolutely sure, contact Taoglas and we will test. Choosing a Taoglas antenna with a higher peak gain than what is specified by the module manufacturer and enlisting our help will ensure you are getting the best performance possible without exceeding the peak gain limits.

The antenna housing is completely waterproof to IP67, and also to IP69K, which means it is waterproof against high pressure water jets used in industrial environments for cleaning.

2. Specifications

ELECTRICAL						
Frequency (GHz)	2.4	2.45	2.5	5.15	5.25	5.35
VSWR	1.46	1.66	1.6	1.76	1.41	1.48
Return Loss (dB)	-14.5	-12.1	-12.7	-11.1	-15.3	-14.2
Impedance	50Ω					
Polarization	Linear - Horizontal					
Radiation Pattern	Omni					
Cable/Connectors	3M NFC-200/RP-SMA(M)					
Recommended Mounting Torque	24.5N·m					
Maximum Mounting Torque	29.4N·m					
MECHANICAL						
Dimensions	Height 29mm x Diameter 49mm					
Casing	UV resistant PC					
Base and thread	Nickel plated steel					
Thread diameter	18mm					
Weather proof gasket	CR4305 foam with 3M9448B double-side adhesive					
ENVIRONMENTAL						
Waterproof	IP67 & IP69K					
Corrosion	5% NaCl for 48hrs - Nickel plated steel base and thread					
Temperature Range	-40°C to +85°C					
Thermal Shock	100 cycles -40°C to +80°C					
Humidity	Non-condensing 65°C 95% RH					
Shock (drop test)	1m drop on concrete 6 axes					
Cable pull	8 KGf					

3. Antenna S11 Parameters

3.1. Return Loss



3.2. VSWR



4. Antenna Radiation

4.1. 3D Radiation Pattern

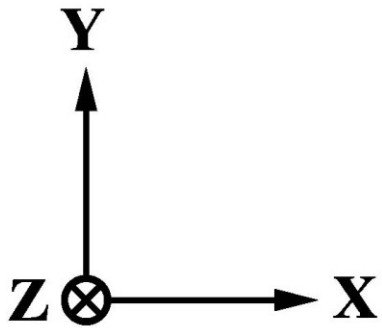

2.4GHz

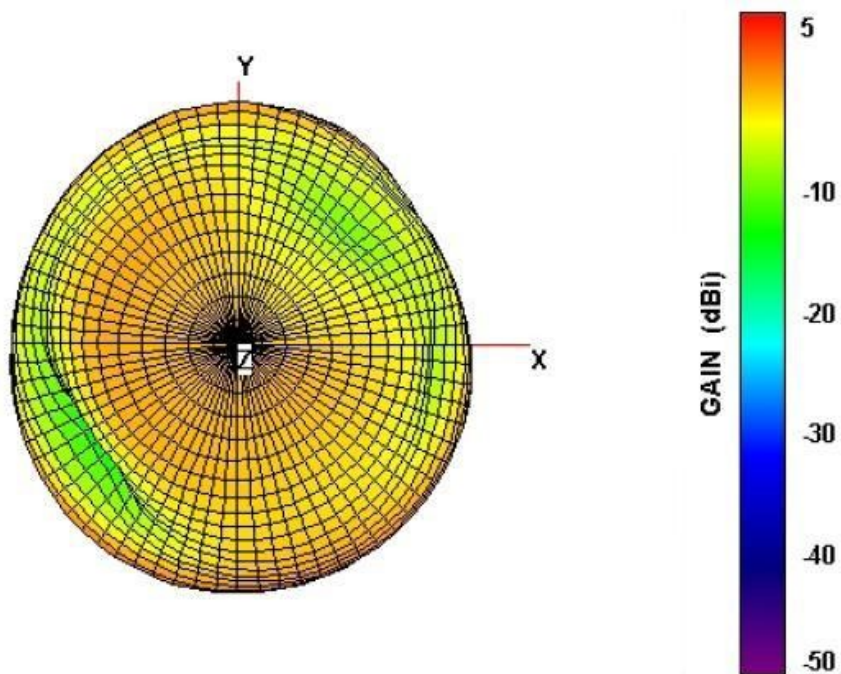

2.45GHz

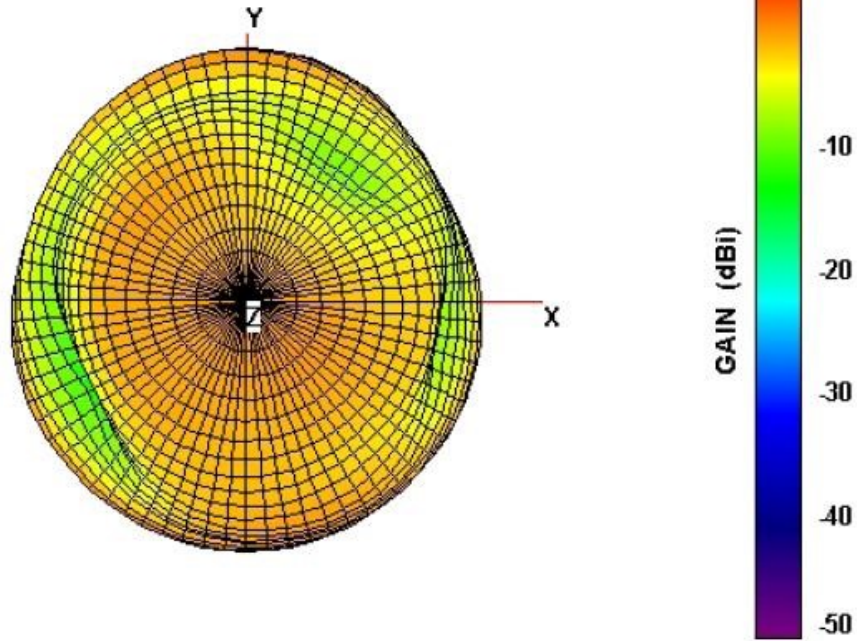

2.5GHz

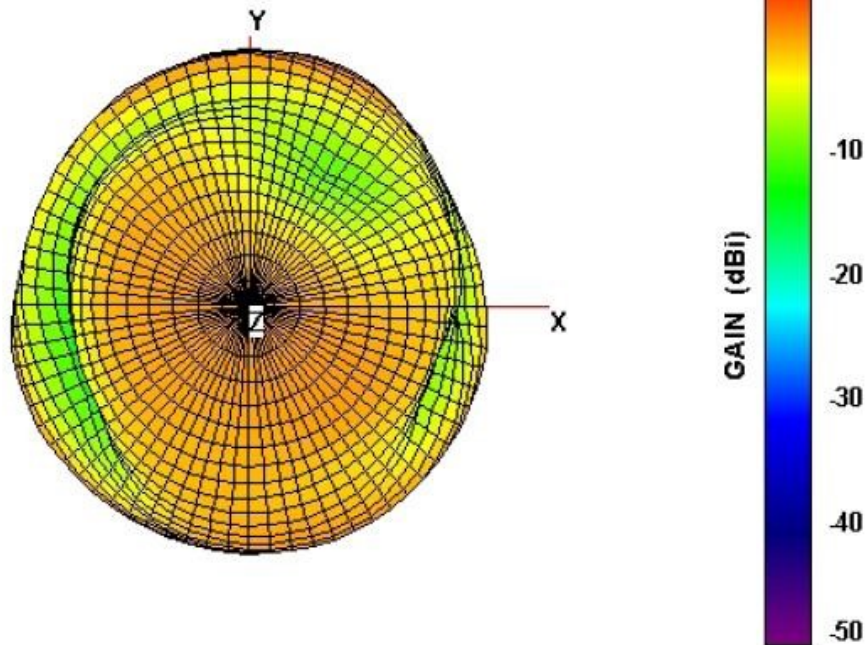

5.15GHz

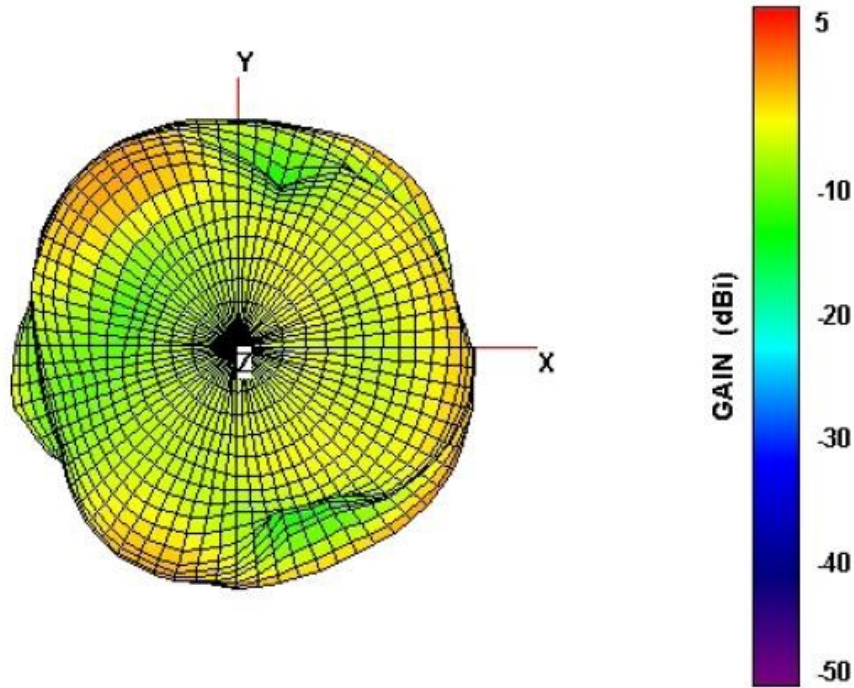

5.25GHz

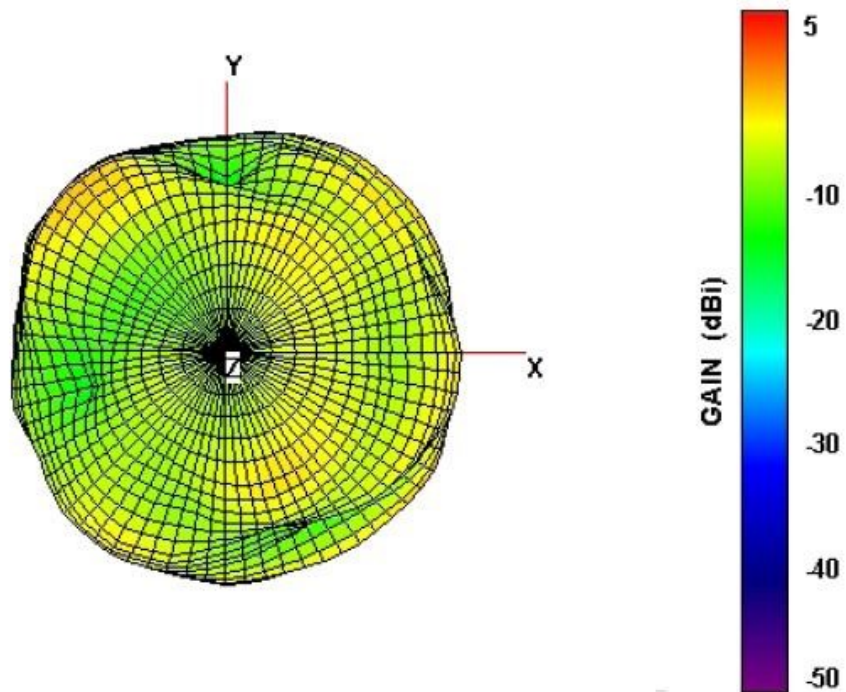

5.35GHz

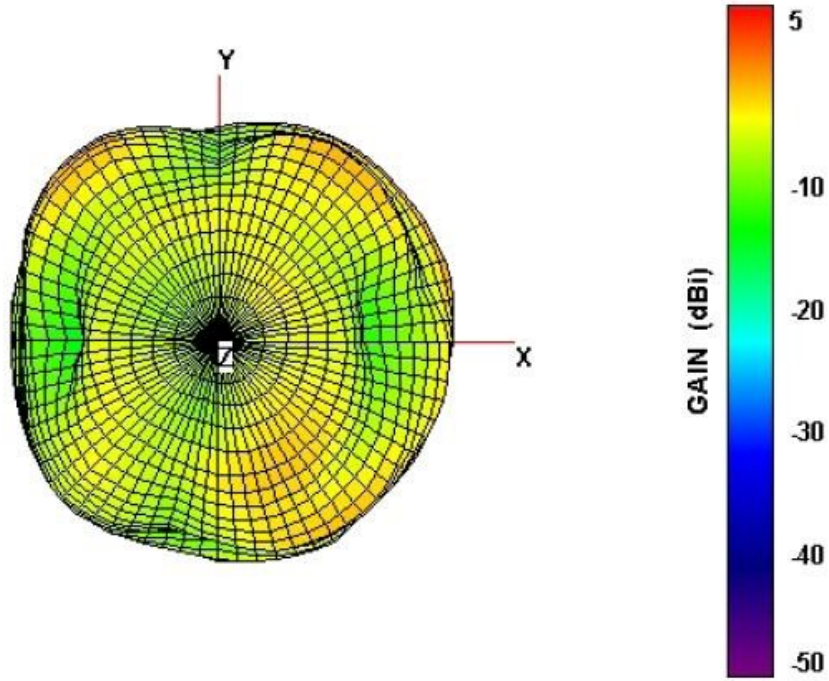

4.2. Result Summary

Channel	2400	2450	2500	5150	5250	5350
Note						
Ant. Port Input Pwr. [dBm]	0	0	0	0	0	0
Tot. Rad. Pwr. [dBm]	-1.98761	-1.61782	-1.77651	-3.01447	-3.8051	-3.23583
Peak EIRP [dBm]	3.0513	4.05447	4.1152	4.7407	4.37813	4.71773
Directivity [dBi]	5.03891	5.67229	5.89171	7.75517	8.18322	7.95356
Efficiency [dB]	-1.98761	-1.61782	-1.77651	-3.01447	-3.8051	-3.23583
Efficiency [%]	63.276	68.8997	66.4276	49.952	41.638	47.4698
Gain [dBi]	3.0513	4.05447	4.1152	4.7407	4.37813	4.71773
NHPRP ±Pi/4 [dBm]	-3.25016	-2.86259	-3.02232	-4.67614	-5.69757	-5.29538
NHPRP ±Pi/6 [dBm]	-4.39266	-4.02363	-4.19465	-6.60698	-7.70604	-7.19484
NHPRP ±Pi/8 [dBm]	-5.32364	-5.01353	-5.19258	-7.87659	-8.98205	-8.37507
Upper Hem. PRP [dBm]	-6.08301	-5.80993	-5.86805	-7.71601	-8.71586	-8.08409
Lower Hem. PRP [dBm]	-4.13045	-3.70008	-3.92182	-4.81064	-5.49788	-4.95872
NHPRP4 / TRP Ratio [dB]	-1.26255	-1.24477	-1.2458	-1.66167	-1.89247	-2.05955
NHPRP4 / TRP Ratio [%]	74.773	75.0798	75.062	68.2076	64.6774	62.2365
NHPRP6 / TRP Ratio [dB]	-2.40505	-2.4058	-2.41814	-3.59251	-3.90094	-3.95901
NHPRP6 / TRP Ratio [%]	57.4771	57.4672	57.3041	43.7269	40.7292	40.1882
NHPRP8 / TRP Ratio [dB]	-3.33604	-3.39571	-3.41607	-4.86212	-5.17695	-5.13924
NHPRP8 / TRP Ratio [%]	46.387	45.754	45.54	32.6428	30.3602	30.625
UHPRP / TRP Ratio [dB]	-4.0954	-4.19211	-4.09154	-4.70155	-4.91076	-4.84826
UHPRP / TRP Ratio [%]	38.9457	38.0881	38.9804	33.8723	32.2793	32.7472
LHPRP / TRP Ratio [dB]	-2.14284	-2.08226	-2.1453	-1.79617	-1.69279	-1.7229
LHPRP / TRP Ratio [%]	61.0543	61.9119	61.0196	66.1277	67.7207	67.2528
Front/Back Ratio [dB]	3.42725	3.56765	3.94055	10.1253	13.1799	10.9587
Phi BW [°]	112	96	86	42	40	42
+ Phi BW [°]	66	58	52	17	19	24
- Phi BW [°]	46	38	34	25	21	18
Theta BW [°]	49	35	35	36	34	32
+ Th. BW [°]	25	20	24	23	23	12
- Th. BW [°]	24	15	11	13	11	20
Boresight Phi [°]	270	270	270	75	75	60
Boresight Th. [°]	105	105	105	135	135	150
Maximum Power [dBm]	3.0513	4.05447	4.1152	4.7407	4.37813	4.71773
Minimum Power [dBm]	-15.0552	-14.2956	-14.3893	-15.5291	-16.4014	-15.3489
Average Power [dBm]	-2.26887	-1.84221	-2.02397	-3.4037	-4.13521	-3.4448
Max/Min Ratio [dB]	18.1065	18.3501	18.5045	20.2699	20.7795	20.0666
Max/Avg Ratio [dB]	5.32018	5.89668	6.13917	8.14441	8.51333	8.16253
Max/Avg Ratio [dB]	-12.7863	-12.4534	-12.3653	-12.1254	-12.2662	-11.9041
Average Gain [dB]	-1.98761	-1.61782	-1.77651	-3.01447	-3.8051	-3.23583
E-Plane BW [°]	45	33	34	32	31	35
+ E-Plane BW [°]	20	18	22	19	20	12
- E-Plane BW [°]	25	15	12	13	11	23
H-Plane BW [°]	115	105	93	51	45	39
+ H-Plane BW [°]	69	70	65	16	16	20
- H-Plane BW [°]	46	35	28	35	29	19

5. Technical Drawing

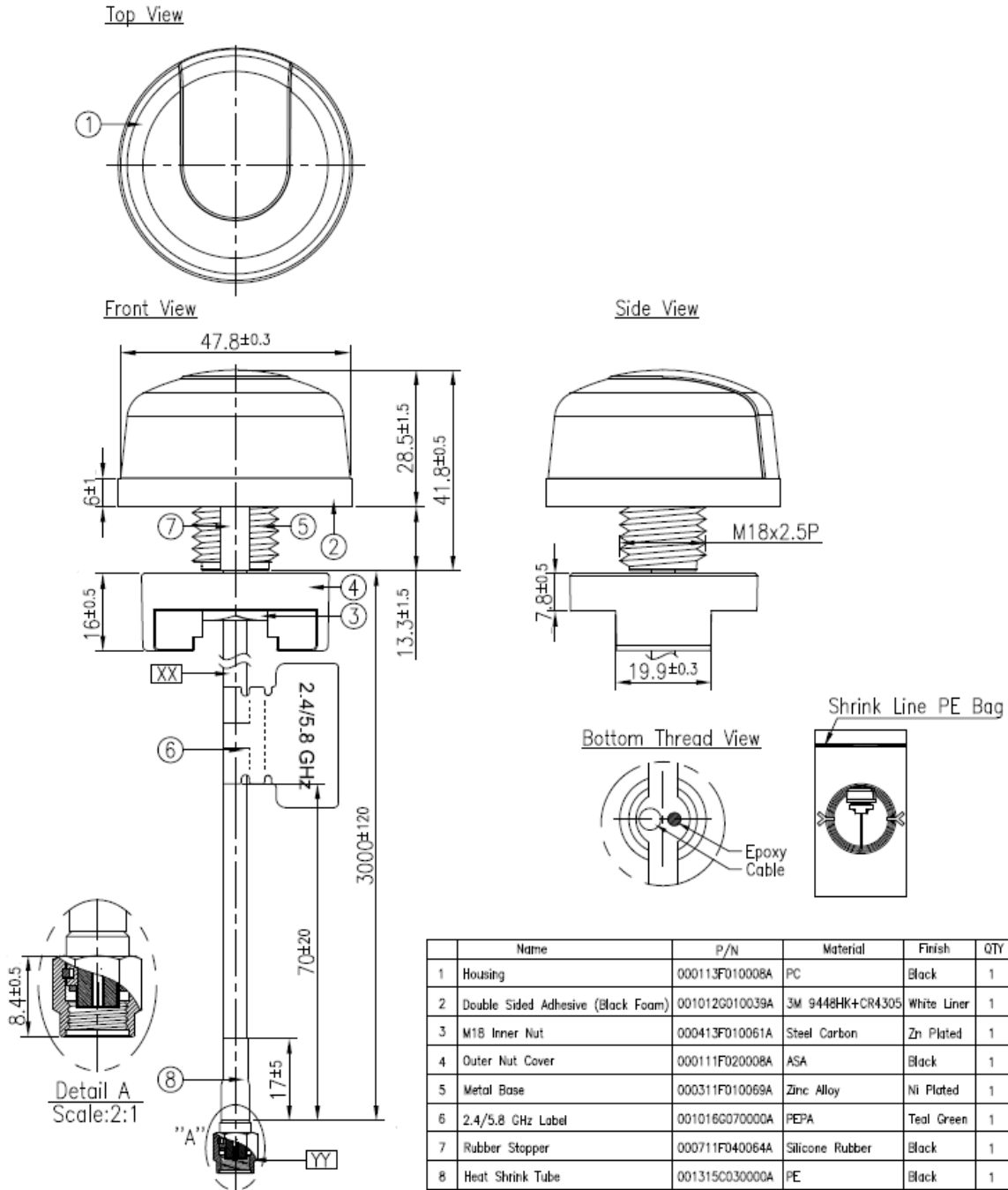

Name	P/N	Material	Finish	QTY
1 Housing	000113FD10008A	PC	Black	1
2 Double Sided Adhesive (Black Foam)	001012G010039A	3M 9448HK+CR4305	White Liner	1
3 M18 Inner Nut	000413FD10061A	Steel Carbon	Zn Plated	1
4 Outer Nut Cover	000111FD20008A	ASA	Black	1
5 Metal Base	000311FD10069A	Zinc Alloy	Ni Plated	1
6 2.4/5.8 GHz Label	001016G070000A	PEPA	Teal Green	1
7 Rubber Stopper	000711FD40064A	Silicone Rubber	Black	1
8 Heat Shrink Tube	001315C030000A	PE	Black	1

Name	P/N	Spec	Finish	QTY
XX Cable Type	301415C030000A	NFC200	Black	1
YY Connector Type	200211G010013A	RP-SMA(M)ST	Au Plated	1

6. Installation

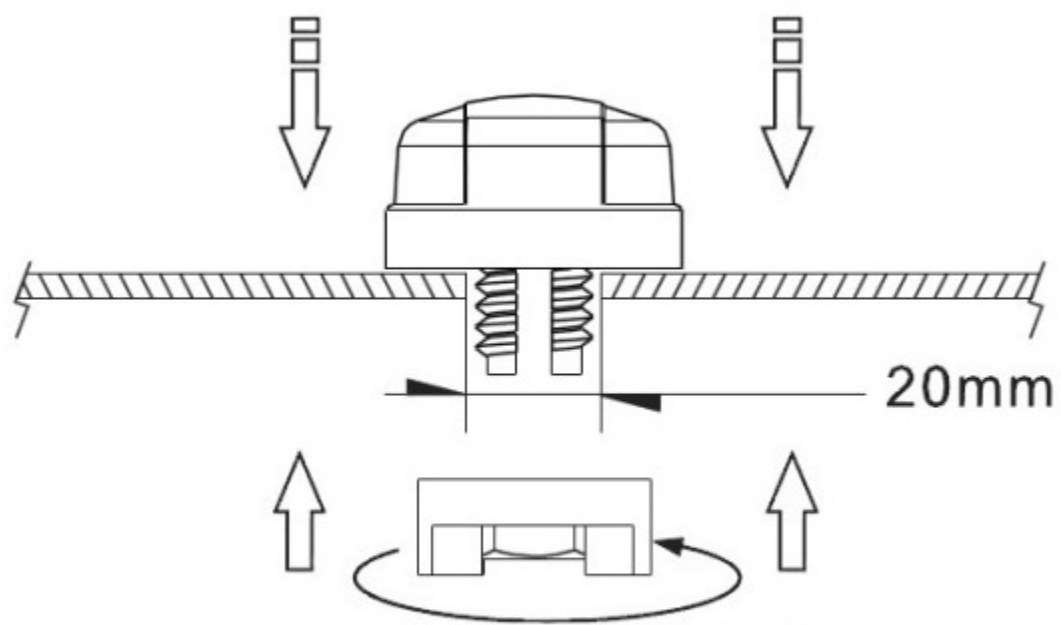

Recommended torque for Mounting is 24.5N·m
Maximum torque for mounting is 29.4N·m



7. Packaging

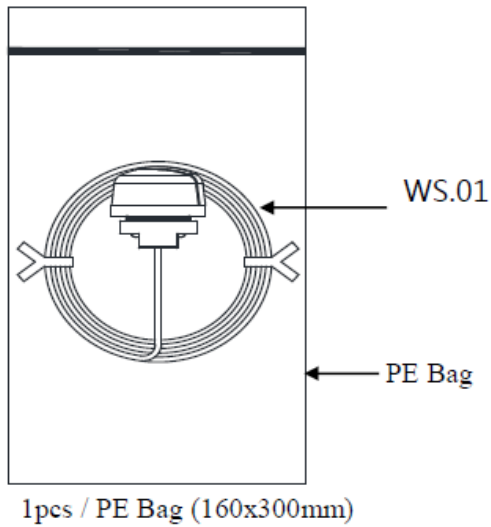

SPQ: 50pcs / Carton
(390x260x330mm)

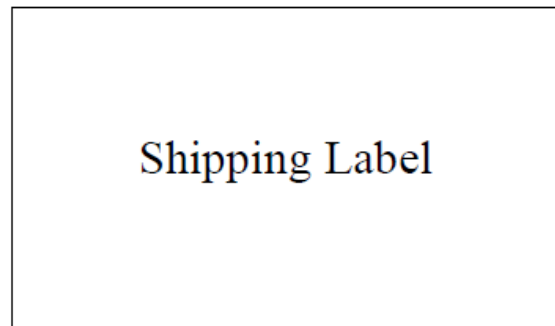



Taoglas makes no warranties based on the accuracy or completeness of the contents of this document and reserves the right to make changes to specifications and product descriptions at any time without notice. Taoglas reserves all rights to this document and the information contained herein.

Reproduction, use or disclosure to third parties without express permission is strictly prohibited.

Copyright © Taoglas Ltd.