

# WLB72I Inspection LED Light Bar (AC)



## Datasheet

Banner's WLB72 Inspection is a very bright LED luminaire that features an even light output for a no glare glow. The WLB72 Inspection product is designed specifically for use in paint and surface inspection tunnels in motor vehicle, construction machinery, and aerospace manufacturing. The WLB72 Inspection uses advanced LED lighting technology to provide a high-quality and maintenance free industrial lighting solution. The unique lensing provides a dark-to-light-to-dark transition on a vehicle surface suitable for detailed inspection tasks.

- Increases worker recognition of surface defects of varying types
- Bright, high-quality, uniform LED light
- Exceptionally energy efficient for overall cost savings
- Durable light with a metal housing and shatter-resistant window
- Intensity can be controlled from 5% to 100% using a compatible dimmer
- Rated for use at 120 V AC to 277 V AC
- Fast installation with multiple integrated mounting options or accessory brackets

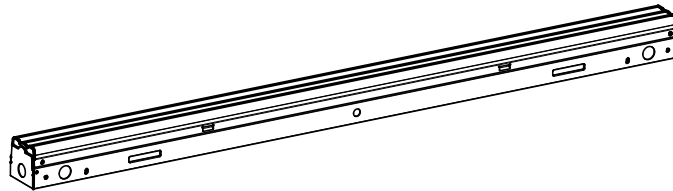

The WLB72 Inspection LED Light Bars are continuous run models that come with 1/2-inch conduit knockouts on the side, back, and both end caps that allow for lights to be cascaded or "daisy-chained" for a continuous length of light. WLB72 Inspection models come with a one year, limited warranty. To view or download the latest technical information about this product, including specifications, dimensions, accessories, and wiring, see [www.bannerengineering.com](http://www.bannerengineering.com).



**Important:** Read the following instructions before operating the light. Please download the complete WLB72I Inspection LED Light Bar technical documentation, available in multiple languages, from [www.bannerengineering.com](http://www.bannerengineering.com) for details on the proper use, applications, Warnings, and installation instructions of this device.



**Important:** Lea el siguiente instructivo antes de operar el luminario. Por favor descargue desde [www.bannerengineering.com](http://www.bannerengineering.com) toda la documentación técnica de los WLB72I Inspection LED Light Bar, disponibles en múltiples idiomas, para detalles del uso adecuado, aplicaciones, advertencias, y las instrucciones de instalación de estos dispositivos.



**Important:** Lisez les instructions suivantes avant d'utiliser le luminare. Veuillez télécharger la documentation technique complète des WLB72I Inspection LED Light Bar sur notre site [www.bannerengineering.com](http://www.bannerengineering.com) pour les détails sur leur utilisation correcte, les applications, les notes de sécurité et les instructions de montage.

## Models

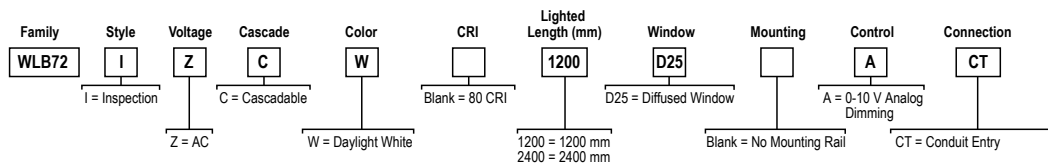

## Installation Instructions

### Install the Light

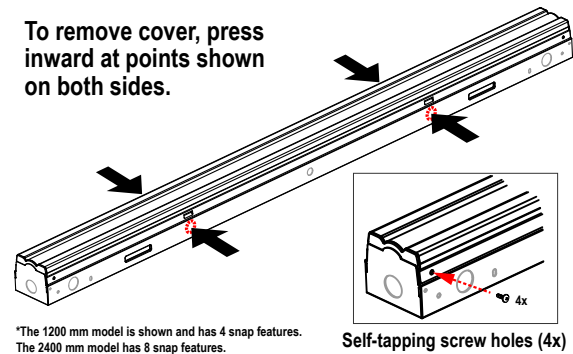

Figure 1. Removing the cover



#### WARNING:

- **Risk of Electric Shock**
- Failure to follow these instructions could result in serious injury or death.
- Installation and service of luminaires should be performed by a qualified licensed electrician.
- Disconnect or turn off power before installing, removing, or servicing luminaire. Luminaire must be installed and connected in accordance with the National Electrical Code (NEC) and any applicable local code requirements. Luminaire must be supplied with a 120–277 V ac 50/60 Hz fuse box or circuit breaker.

To mount the WLB72I Inspection LED Light Bar, follow these steps.

1. Remove luminaire from packaging and inspect for damage before installing.
2. Determine the mounting method and location. The WLB72 is rated for wall, ceiling, or under cabinet mounting. Optional mounting brackets are available, see [Accessories](#) on p. 6.
3. Remove the cover from the housing by pressing inward at the snap features on the housing, starting at one end and progressing to the other.
4. Place the light in the mounting location and mark the positions of the light mounting holes.
5. Drill the holes and use the appropriate screws to secure the luminaire to the mounting location.

### Wire the Light

Follow these steps to wire your WLB72I Inspection LED Light Bar.

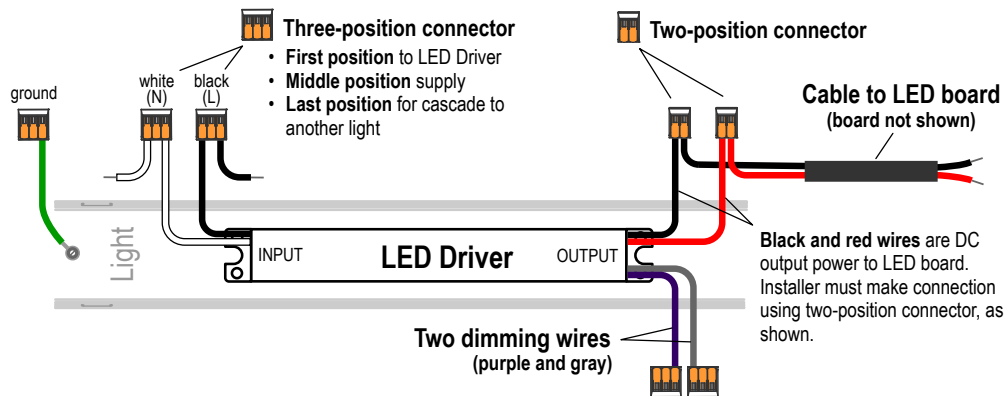

Figure 2. 1200 mm Model

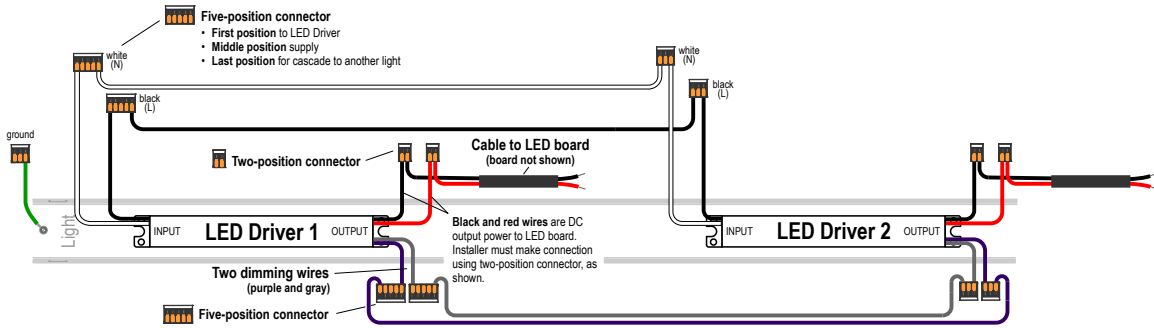

Figure 3. 2400 mm Model

1. Remove the cover from the housing by pressing inward at the snap locations on the housing, starting at one end and progressing to the other.
2. Connect the power by removing the selected knockout and installing either 1/2-inch conduit or an AC power cord with supplied cord grip strain relief. If you are using rigid conduit, the conduit hub/connector must be approved for use in dry or damp locations and must be connected to the conduit before the hub/connector is connected to the luminaire. The supplied cord grip diameter range is 4.3 mm to 11.4 mm.
3. Connect the incoming supply wires to the LED Driver input connectors according to the wiring diagram.
  - a. For 2400 mm models, connect the LED Driver input wires together using supplied wiring.
4. Connect the ground wire to the three-position ground connector.
5. If you are using 0-10 V analog dimming, connect to the LED Driver dimming connectors according to the wiring diagram.
  - a. For 2400 mm models, connect the LED Driver dimming wires together using supplied wiring.
6. Attach the red and black wires from the cover LED board to the output connectors on each Driver.
  - a. For 2400 mm models, there are two Drivers, and two sets of red and black wires.
7. Re-attach the cover to the housing by snapping it into place. Secure the cover to the housing by using a minimum of one self tapping screw on each end of the housing (four screws are provided).
8. Repeat these steps if you are connecting more than one luminaire in a continuous run.

### Wiring Diagram

Diagram	Wire	Connection
	L - Black	Line/Hot
	N - White	Neutral
	- Green/Yellow	Earth ground
	Dim (+) - Purple	0-10 V dc analog dimming
	Dim (-) - Gray	Return analog dimming

## Specifications

### Supply Voltage

Nominal voltage: 120 V AC to 277 V AC, 60 Hz in North America  
 Nominal voltage: 120 V AC to 277 V AC, 50/60 Hz outside North America  
 Power factor: > 0.95 at 120 V AC and > 0.90 at 277 V AC  
 Total harmonic distortion (THD): < 20%  
 See electrical characteristics on product label

### Supply Current

Lighted Length (mm)	Max. Current Draw (A) at 90 V AC	Typical Current Draw (A)		
		120 V AC	230 V AC	277 V AC
1200	0.850	0.43	0.22	0.18
2400	1.700	0.86	0.44	0.36

### Supply Protection Circuitry

Protected against transient voltages

### LED Lifetime

When operating within specifications, output will decrease less than 30% after 50,000 hours.

### Light Characteristics

CRI: 82, typical

Model	Color	Color Temperature (CCT)	Lumens (Typical at 25 °C)
1200	Daylight White	5000 K (±300 K)	4225
2400	Daylight White	5000 K (±300 K)	8350

### Dimming

Compatible with 0-10 V analog LED dimming, dimmable to 5% intensity  
 Shielded wiring required for dimming control

### Application Notes

When connecting continuous run/cascadable lights in series, it is important not to exceed maximum current limitations of 14 AWG, 75 °C wire, in accordance with the National Electrical Code (NEC) and any applicable local code requirements.

Two or more lights installed in parallel must maintain a 150 mm (6 in) spacing to maintain a 50 °C operation temperature.

### Certifications and Approvals



UL/cULus E470122

### Construction

Galvanized steel with corrosion resistant polyester powder coat, polycarbonate window and end caps

### Mounting

Compatible with a variety of common mounting methods. Housing includes mounting holes for surface mounting.

1200 mm model requires two mounting locations

2400 mm model requires four mounting locations

Several optional mounting brackets are available (see [Accessories](#) on p. 6)

### Connections

1/2-inch trade size conduit knockout in nine locations

### Weight

1200 model: 2.8 kg (6.2 lbs)

2400 model: 5.6 kg (12.3 lbs)

### Environmental Rating

IEC IP20

### Operating Temperature

Surface Mount Installation: -20 °C to +50 °C (-4 °F to +122 °F)

85% at +50 °C maximum relative humidity (non-condensing)

### Storage Temperature

-40 °C to +70 °C (-40 °F to +158 °F)

### Vibration and Mechanical Shock

Vibration: 10 Hz to 55 Hz, 0.5 mm peak-to-peak amplitude per IEC 60068-2-6 (5 minute sweep, 30 minute dwell)

Shock: 5G 11 ms duration, half sine wave per IEC 60068-2-27

Impact: IK07 (IEC 60068-2-75)

### Required Overcurrent Protection



**WARNING:** Electrical connections must be made by qualified personnel in accordance with local and national electrical codes and regulations.

Overcurrent protection is required to be provided by end product application per the supplied table.

Overcurrent protection may be provided with external fusing or via Current Limiting, Class 2 Power Supply.

Supply wiring leads < 24 AWG shall not be spliced.

For additional product support, go to [www.bannerengineering.com](http://www.bannerengineering.com).

Supply Wiring (AWG)	Required Overcurrent Protection (Amps)
20	5.0
22	3.0
24	2.0
26	1.0
28	0.8
30	0.5

## Performance Curves

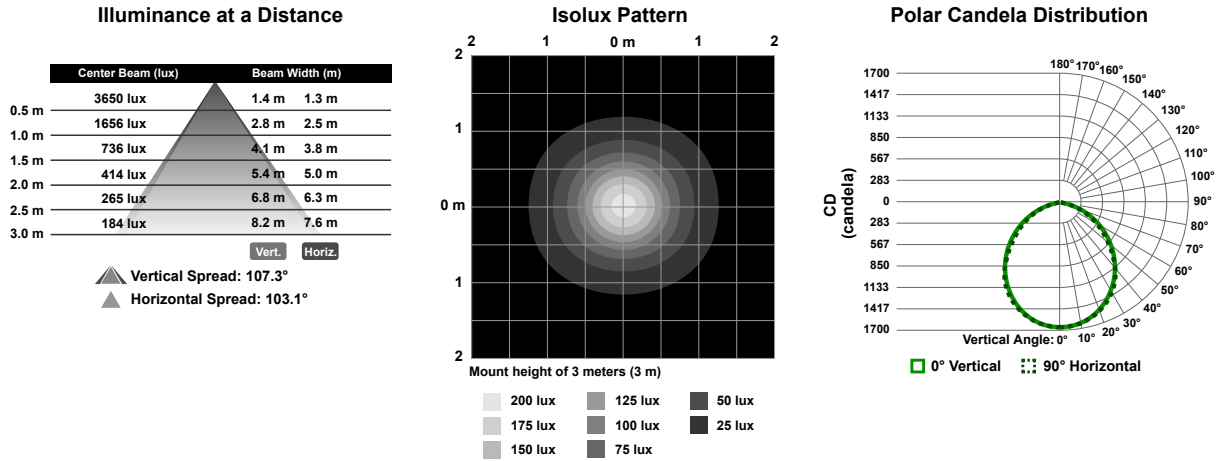

Figure 4. 1200 mm Model

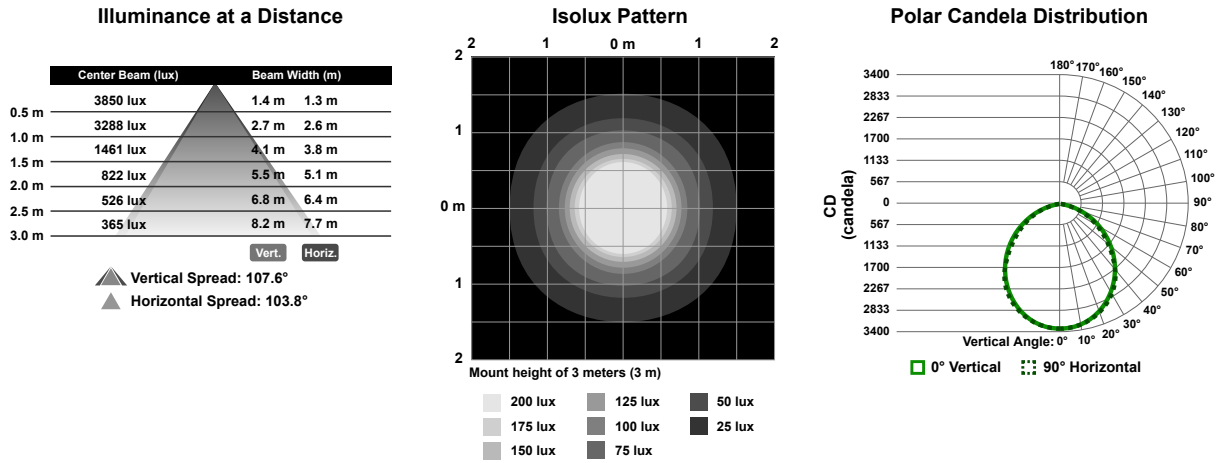

Figure 5. 2400 mm Model

## Dimensions

All measurements are listed in millimeters [inches], unless noted otherwise.

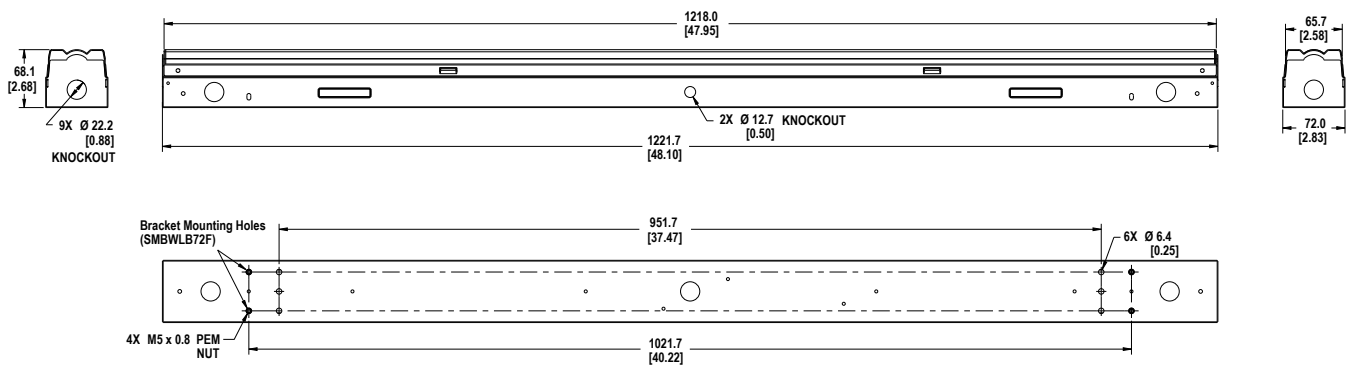

Figure 6. 1200 mm Model

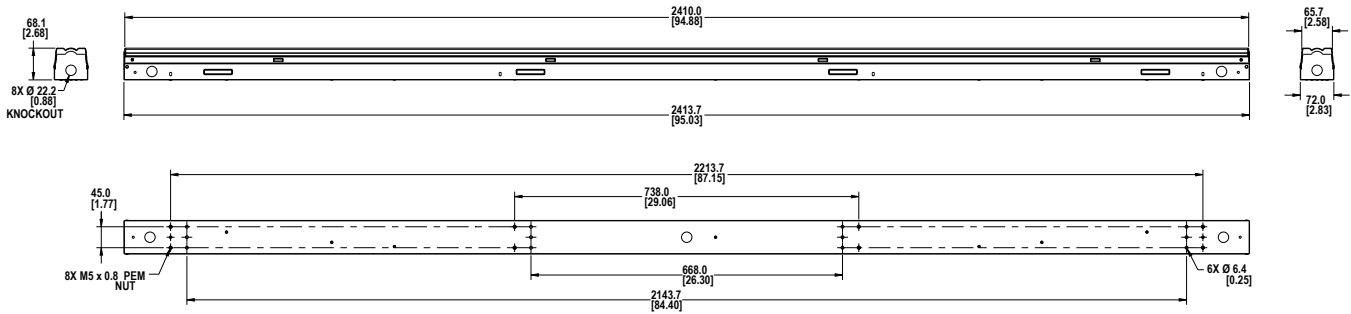

Figure 7. 2400 mm Model

## Accessories

### Brackets

All measurements are listed in millimeters, unless noted otherwise.

#### LMBWLB72F

- Stainless steel
- Includes two surface mount brackets and four screws for mounting onto the housing

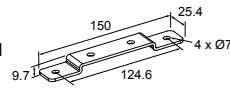

#### LMBWLB72RAS

- Swivel brackets allow for 180° of movement in seven fixed positions
- Stainless steel
- Includes two swivel bracket assemblies and eight screws

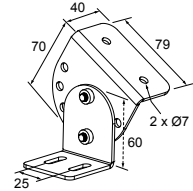

**Note:** The 2400 mm model requires four brackets for mounting. Order two of the above bracket model numbers.

### Other Accessories

#### ACC-WLB72-CSR-5 Cord Grip Accessory (5 pack with nuts)

- One strain relief is included with each WLB72 light
- Cable diameter: 4.3 mm to 11.4 mm (0.17 in to 0.45 in)
- For use in clearance holes 22.2 mm (0.875 in) or threaded holes ½ NPT
- Nylon 6/6 construction with TPE sealing gland resists common solvents
- IEC IP68 rated (70 psi, 5 Bar)
- Flammability Rating 94V-2
- Temperature: -40 °C to 115 °C (-40 °F to 239 °F)

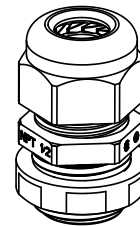

## Banner Engineering Corp. Limited Warranty

Banner Engineering Corp. warrants its products to be free from defects in material and workmanship for one year following the date of shipment. Banner Engineering Corp. will repair or replace, free of charge, any product of its manufacture which, at the time it is returned to the factory, is found to have been defective during the warranty period. This warranty does not cover damage or liability for misuse, abuse, or the improper application or installation of the Banner product.

**THIS LIMITED WARRANTY IS EXCLUSIVE AND IN LIEU OF ALL OTHER WARRANTIES WHETHER EXPRESS OR IMPLIED (INCLUDING, WITHOUT LIMITATION, ANY WARRANTY OF MERCHANTABILITY OR FITNESS FOR A PARTICULAR PURPOSE), AND WHETHER ARISING UNDER COURSE OF PERFORMANCE, COURSE OF DEALING OR TRADE USAGE.**

This Warranty is exclusive and limited to repair or, at the discretion of Banner Engineering Corp., replacement. **IN NO EVENT SHALL BANNER ENGINEERING CORP. BE LIABLE TO BUYER OR ANY OTHER PERSON OR ENTITY FOR ANY EXTRA COSTS, EXPENSES, LOSSES, LOSS OF PROFITS, OR ANY INCIDENTAL, CONSEQUENTIAL OR SPECIAL DAMAGES RESULTING FROM ANY PRODUCT DEFECT OR FROM THE USE OR INABILITY TO USE THE PRODUCT, WHETHER ARISING IN CONTRACT OR WARRANTY, STATUTE, TORT, STRICT LIABILITY, NEGLIGENCE, OR OTHERWISE.**

Banner Engineering Corp. reserves the right to change, modify or improve the design of the product without assuming any obligations or liabilities relating to any product previously manufactured by Banner Engineering Corp. Any misuse, abuse, or improper application or installation of this product or use of the product for personal protection applications when the product is identified as not intended for such purposes will void the product warranty. Any modifications to this product without prior express approval by Banner Engineering Corp will void the product warranties. All specifications published in this document are subject to change; Banner reserves the right to modify product specifications or update documentation at any time. Specifications and product information in English supersede that which is provided in any other language. For the most recent version of any documentation, refer to: [www.bannerengineering.com](http://www.bannerengineering.com).

For patent information, see [www.bannerengineering.com/patents](http://www.bannerengineering.com/patents).