

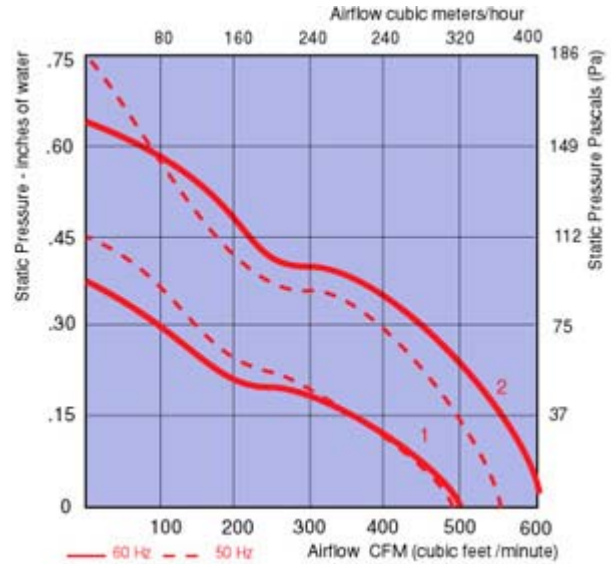

## W2E200T Series Tubeaxial

AC fan, metal housing, metal impeller, terminal block. Air exhaust over struts. UL, CSA, VDE approvals

Part Number	CFM @ 0	Curve	Volts	Hertz	Power (W)	Power dBA	Max Ambient Temp C	Wgt. (lbs)	Type Of Bearing	Features	Size
W2E200-HH64-05	500	1	230	50/60	60	56	75	4.38	Ball	Terminal Block	225 x 225 x 80 mm
W2E200-HH82-01	500	1	115	50/60	60	56	75	4.38	Ball	Terminal Block	225 x 225 x 80 mm
W2E200-HH38-01	607	2	230	50/60	80	61	75	4.38	Ball	Terminal Block	225 x 225 x 80 mm
W2E200-HH86-01	607	2	115	50/60	80	61	75	4.38	Ball	Terminal Block	225 x 225 x 80 mm

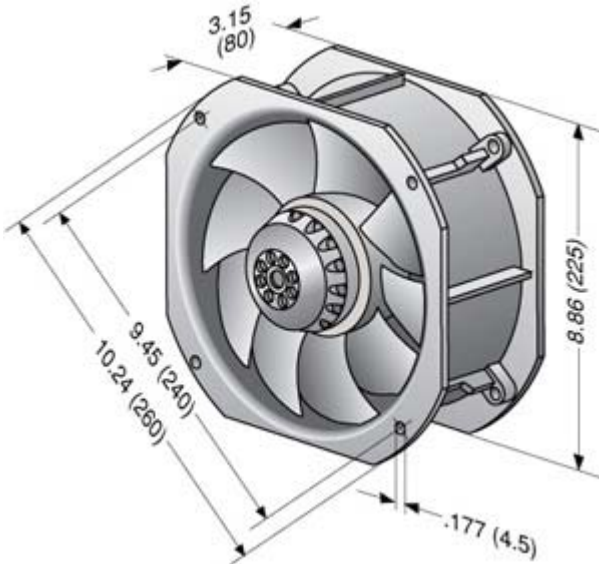

Options  
Accessories  
Features

DXF (2-D)  
CAD Drawing  
(to download)

DWG (2-D)  
CAD Drawing  
(to download)

IGES (3-D)  
CAD Drawing  
(to download)

E-mail: [sales@ebm.com](mailto:sales@ebm.com) • TEL: 860-674-1515 • FAX: 860-674-8536  
 ebm Industries Inc., 100 Hyde Road, Farmington, CT 06034 USA  
 ebm Industries, Inc., 2000-2002 • ebm Industries, Inc. reserves the right to change any specifications or data without notice

Page Reference  
W2E200T-12/18/2002