

W2D300-CP02-31

AC axial fan

sickled blades (S series)

with full round nozzle



ebm-papst Mulfingen GmbH & Co. KG

Bachmühle 2

74673 Mulfingen

Phone: +49 7938 81-0

Fax: +49 7938 81-110

www.ebmpapst.com

info1@de.ebmpapst.com

Nominal data

Type	W2D300-CP02-31		
Motor	M2D074-DF		
Phase		3~	3~
Nominal voltage	[V]	230	400
Connection		D	Y
Frequency	[Hz]	50	50
Type of data definition		rfa	rfa
Valid for approval / standard		CE	CE
Speed	[min ⁻¹]	2580	2580
Power input	[W]	210	210
Current draw	[A]	0.62	0.36
Max. back pressure	[Pa]	200	200
Max. ambient temperature	[°C]	55	55

ml = max. load · me = max. efficiency · rfa = running at free air · cs = customer specs · cu = customer unit
Subject to alterations

AC axial fan

sickled blades (S series)

with full round nozzle

Technical features

Leakage current	< 0,75 mA
Size	300 mm
Operation mode	S1
Direction of rotation	Clockwise, seen on rotor
Mounting position	Shaft horizontal or rotor on bottom; rotor on top on request
Humidity class	F1-2
Direction of air flow	"A"
Insulation class	"B"
Cable exit	Variable
Condensate discharge holes	Rotor-side
Bearing motor	Ball bearing
Mass	5.3 kg
Material of blades	Sheet steel, coated in black
Material of guard grille	Steel, phosphated and coated in black plastic
Material of wall ring	Sheet steel, pre-galvanized and coated in black plastic
Product conforming to standard	EN 60335-1
Surface of rotor	Coated in black
Option	With terminal box
Number of blades	5
Type of protection	IP 44
Protection class	I
Max. permissible ambient motor temp. (transp./ storage)	+ 80 °C
Min. permissible ambient motor temp. (transp./storage)	- 40 °C
Approval	CCC

AC axial fan

sickled blades (S series)
with full round nozzle

Product drawing

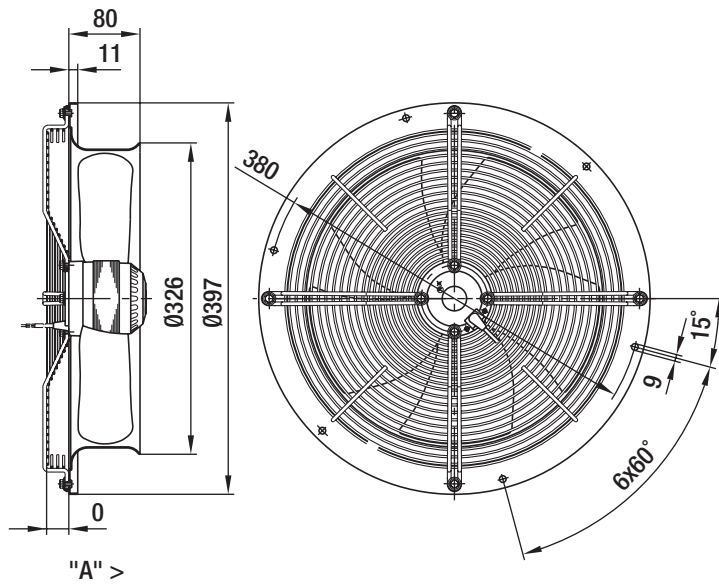

AC axial fan

sickled blades (S series)

with full round nozzle

Connection screen

Delta (3~ 230 VAC)

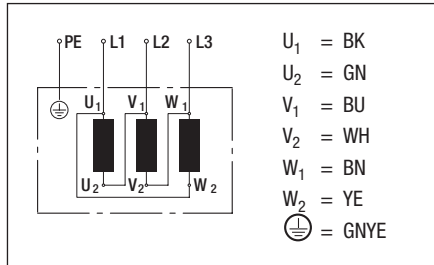

Star (3~ 400 VAC)

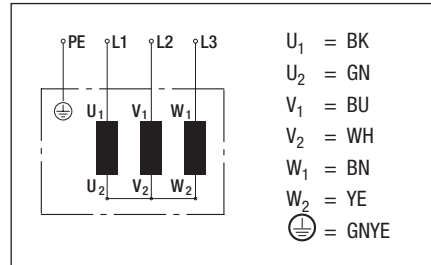

AC axial fan

sickled blades (S series)

with full round nozzle

Charts: Air flow 50 Hz

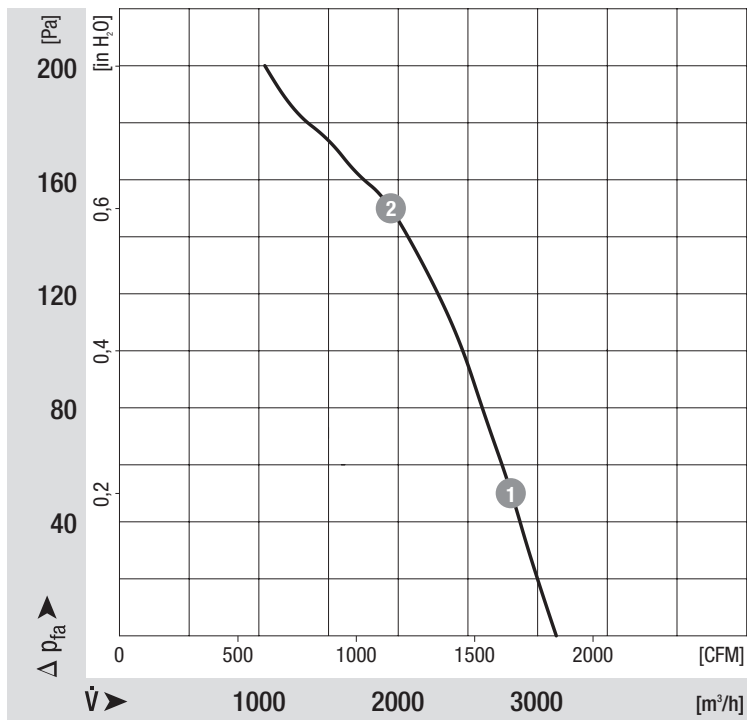

Measured values

	n	P ₁	I
	[min ⁻¹]	[W]	[A]
1	2530	228	0.39
2	2400	273	0.45

AC axial fan

sickled blades (S series)

with full round nozzle

Charts: Air flow 60 Hz

