

# 5 Port Solenoid Valve

## VQC4000/5000 Series

Metal Seal

Rubber Seal

### ■ Compact and large flow capacity

**VQC4000** Possible to drive cylinders up to  $\varnothing 160$

**VQC5000** Possible to drive cylinders up to  $\varnothing 180$  \* When the average speed is 200 mm/s. Refer to page 608 for actual conditions.

**VQC4000: 25 mm pitch**

$C[dm^3/(s\cdot bar)]: 7.3^*$

**VQC5000: 41 mm pitch**

$C[dm^3/(s\cdot bar)]: 17^*$

\* 2-position single, rubber seal: 4/2 → 5/3 (A/B → R1/R2)

### ■ Extensive range of protocols available



  
 EtherNet/IP 



■ EtherNet/IP™ and PROFINET are compatible with wireless systems.

### ■ Connector type manifold

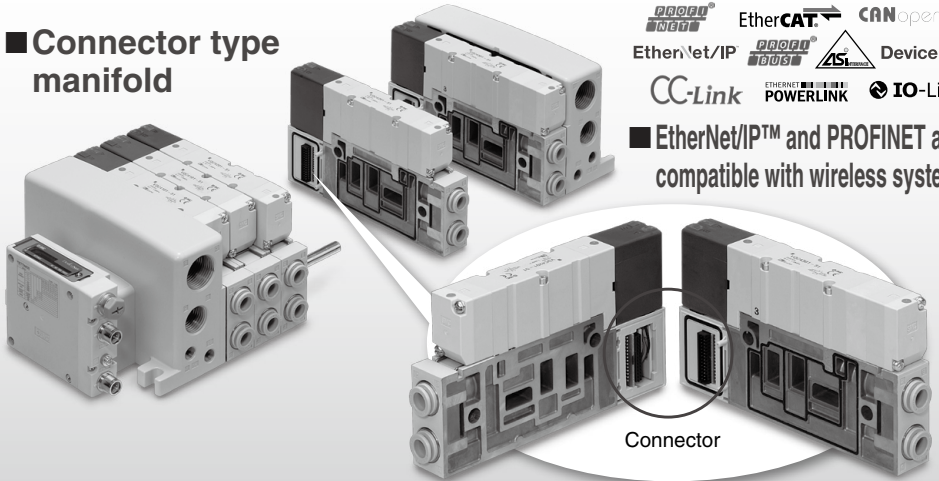

Connector

### ■ Power saving

|                 | Power consumption [W] | Maximum operating pressure [MPa] |
|-----------------|-----------------------|----------------------------------|
| <b>VQC</b>      | <b>0.4</b> (0.95)     | <b>1.0</b>                       |
| Current product | <b>0.5</b> (1.0)      | <b>0.7</b>                       |

\* Low wattage type ( ): Standard

■ Long service life **100 million cycles**  
\* According to SMC life test conditions

■ Enclosure **IP67** compliant

\* Except F and P kits

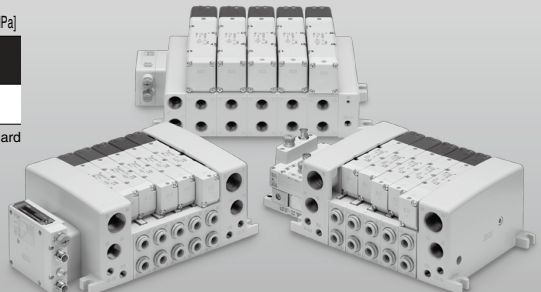

|         |
|---------|
| SV      |
| SYJ     |
| SZ      |
| VF      |
| VP4     |
| VQ 1/2  |
| VQ 4/5  |
| VQC 1/2 |
| VQC 4/5 |
| VQZ     |
| SQ      |
| VFS     |
| VFR     |
| VQ7     |

## ■ Compact and large flow

| Model<br>(Series) | Valve pitch<br>[mm] | Flow rate characteristics <small>(Note)</small> |      |     |                              |      |     |
|-------------------|---------------------|---|------|-----|------------------------------|------|-----|
|                   |                     | Metal seal                                      |      |     | Rubber seal                  |      |     |
|                   |                     | C [dm <sup>3</sup> /(s·bar)]                    | b    | Cv  | C [dm <sup>3</sup> /(s·bar)] | b    | Cv  |
| <b>VQC4000</b>    | 25                  | 6.9   | 0.17 | 1.7 | 7.3                          | 0.38 | 2.0 |
| <b>VQC5000</b>    | 41                  | 14  | 0.18 | 3.4 | 17                           | 0.31 | 4.7 |

Note) Flow rate characteristics: 2-position single, 4/2 → 5/3 (A/B → R1/R2)

## ■ Applicable to EX600 (Input/Output) serial transmission system (Fieldbus system)

### ■ Compatible Protocols

CC-Link **V2**

DeviceNet

**PROFINET**

EtherNet/IP

EtherCAT

**PROFINET**

■ EtherNet/IP™ and PROFINET are compatible with wireless systems.

Reduction in wiring time with SPEEDCON (Phoenix Contact). Just insert and make 1/2 rotation!

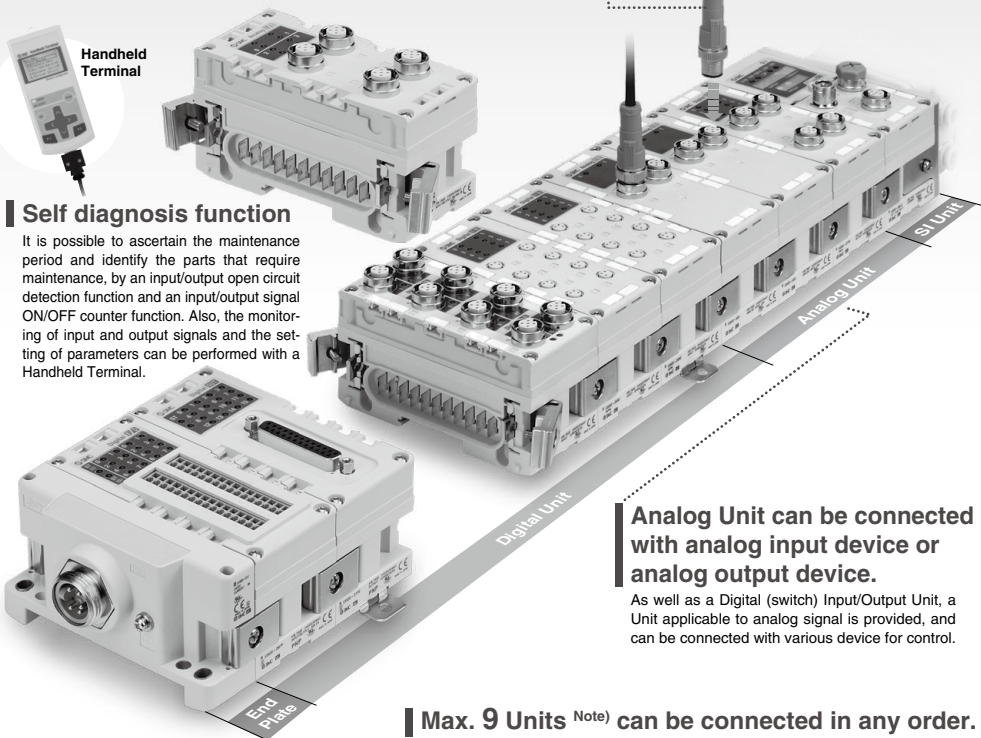

### Self diagnosis function

It is possible to ascertain the maintenance period and identify the parts that require maintenance, by an input/output open circuit detection function and an input/output signal ON/OFF counter function. Also, the monitoring of input and output signals and the setting of parameters can be performed with a Handheld Terminal.

**Analog Unit can be connected with analog input device or analog output device.**

As well as a Digital (switch) Input/Output Unit, a Unit applicable to analog signal is provided, and can be connected with various device for control.

■ **Max. 9 Units** (Note) can be connected in any order.

The Input Unit to connect input device such as an auto switch, pressure switch and flow switch, and the Output Unit to connect output device such as a solenoid valve, relay and indicator light can be connected in any order.

Note) Except SI Unit

## ■ EX260 (Output device for driving 5 port solenoid valves)

### Compatible Protocols



DeviceNet

EtherNet/IP



Compact  
28 mm



|                                      |   |
|--------------------------------------|---|
| <b>Number of outputs</b>             | Each 32/16 digital output type available in the series.<br>(Only the 32 point digital output type is available for IO-Link compatible units.)   |
| <b>Output polarity</b>               | Each negative common (PNP)/positive common (NPN) type available in the series.<br>(Only the negative common (PNP) type is available for Ethernet POWERLINK and IO-Link compatible units.) |
| <b>Enclosure</b>                     | IP67 (For Units with D-sub connector, and when connected with S0700 manifolds, it is IP40.)   |
| <b>Internal terminating resistor</b> | ON/OFF switching is possible with an internal terminating resistor for communication.<br>(Only for Units compatible with M12 PROFIBUS DP, CC-Link communication connectors)               |

## ■ A wide variety of prepackaged wiring configurations

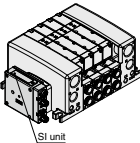
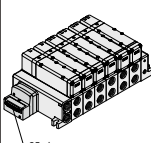
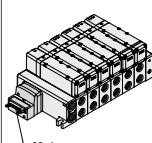
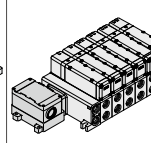
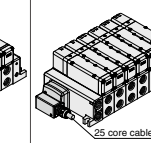
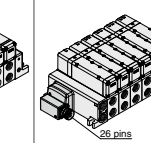
|   |  |  |   |  |  |
|---|--|--|---|--|--|
| <b>S</b> Kit<br>(Serial transmission)<br><br>IP67 enclosure compliant | <b>F</b> Kit<br>(D-sub connector)<br><br>IP40 enclosure compliant | <b>P</b> Kit<br>(Flat ribbon cable)<br><br>IP40 enclosure compliant | <b>T</b> Kit<br>(Terminal block box)<br><br>IP67 enclosure compliant | <b>L</b> Kit<br>(Lead wire)<br><br>IP67 enclosure compliant | <b>M</b> Kit<br>(Circular connector)<br><br>IP67 enclosure compliant |
|---|--|--|---|--|--|

- Our six standard wiring packages bring a world of ease to wiring and maintenance work, while the protective enclosures of four of them conform to IP67 standards.
- The S kit is compatible with a combined I/O Unit. (Not applicable to Gateway Unit)

## ■ Connector type manifold

- The use of multi-pin connectors to replace wiring inside manifold blocks provides flexibility when adding stations or changing manifold configuration.
- All kits use multi-pin connectors, so switching from the F kit (D-sub connector) to the S kit (serial transmission) can be done simply by changing the kit section.

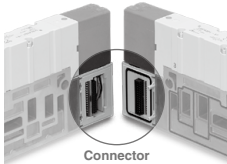

Connector

(Refer to the connector wiring diagram.)  
Printed circuit board patterns between connectors are shifted at every station. This allows for viable connections to take place without necessarily specifying whether the manifold station is double, single, or mixed wiring.

### Connector Wiring Diagram (Mixed wiring)

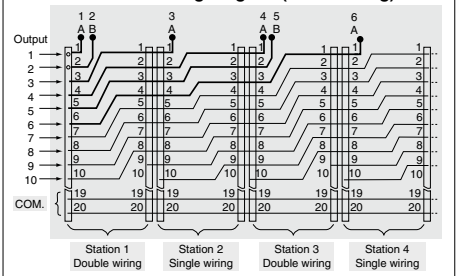

## ■ Connector entry direction can be changed with a single push. (F/P kit)





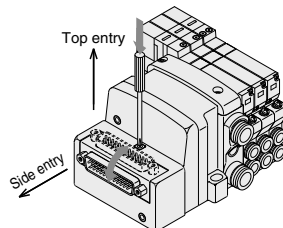

The connector entry direction can be changed from the top to the side by simply pressing the manual release button.

It is not necessary to use the manual release button when switching from the side to the top.



# VQC4000/5000 Series

## Sub-plate/Base Mounted: Variations

|   |   | Sonic conductance C [dm <sup>3</sup> /(s·bar)] | S Kit  |   |  |   |  |   |               |               |
|---|---|--|--|---|--|---|--|---|---------------|---------------|
|   |   |  | Serial transmission  |   |  |   |  |   |               |               |
|   |   |  | EX600  | EX500   | EX260  | EX250   | EX126  |   |               |               |
| <br><b>Sub-plate</b> | <br><b>Base mounted</b> | Values:<br>(CYL → EXH)<br>(4/2 → 5/3)          | Compatible protocol<br>· PROFINET®<br>· EtherCAT<br>· EtherNet/IP™ <sup>※</sup><br>· PROFIBUS DP<br>· DeviceNet™<br>· CC-Link<br>I/O | Compatible protocol<br>· EtherNet/IP™<br>· PROFINET<br>· PROFIBUS DP<br>· DeviceNet™<br>Gateway decentralized type <sup>(Note)</sup><br>I/O | Compatible protocol<br>· PROFINET<br>· EtherCAT<br>· EtherNet/IP™<br>· PROFIBUS DP<br>· DeviceNet™<br>· CC-Link<br>· EtherNet POWERLINK<br>· IO-Link<br>Output | Compatible protocol<br>· EtherNet/IP™<br>· PROFIBUS DP<br>· DeviceNet™<br>· AS-Interface<br>· CANopen<br>I/O                        | Compatible protocol<br>· CC-Link<br>Output   |   |               |               |
|   |   |  | * Compatible with wireless systems   | <br><b>IP67 compliant</b>                                  | <br><b>IP67 compliant</b>   | <br><b>IP67 compliant</b><br><b>IP40 compliant</b> | <br><b>IP67 compliant</b> | <br><b>IP67 compliant</b> |               |               |
|   |   | Single/Double<br>3-position (Closed center)    |  |   |  |   |  |   |               |               |
| Sub-plate   | VQC 4000 Series   | Rubber seal                                    | VQC4□00  | 6.9   | 6.3  |   |  |   |               |               |
|   |   | Metal seal                                     | VQC4□01  | 7.3   | 6.4  |   |  |   |               |               |
|   | VQC 5000 Series   | Rubber seal                                    | VQC5□00  | 14  | 11   | —   | —  | —   | —             | —             |
|   |   | Metal seal                                     | VQC5□01  | 17  | 13   |   |  |   |               |               |
|   | Base Mounted  | VQC 4000 Series                                | Rubber seal  | VQC4□00   | 6.9  | 6.3   | ●<br>Page 614  | ●<br>Page 614   | ●<br>Page 614 | ●<br>Page 614 |
| Metal seal  |   |  | VQC4□01  | 7.3   | 6.4  |   |  |   |               |               |
| VQC 5000 Series   |   | Rubber seal                                    | VQC5□00  | 14  | 11   | ●<br>Page 652   | ●<br>Page 652  | ●<br>Page 652   | ●<br>Page 652 | ●<br>Page 652 |
|   |   | Metal seal                                     | VQC5□01  | 17  | 13   |   |  |   |               |               |

Note) A separate GW Unit and communication cable are required. For details, refer to page 845 in Best Pneumatics No. 1-1.

Manifold options are the same as those for the VQ4000/5000 series. Refer to page 445.

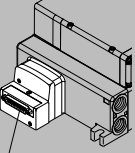
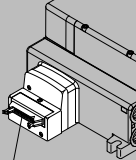
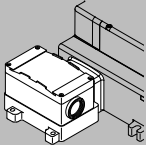
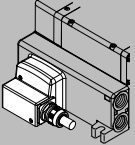
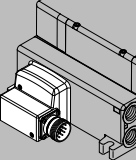
| F Kit   | P Kit  | T Kit  | L Kit   | M Kit   | Port size   |   |
|---|--|--|---|---|---|---|
| D-sub connector   | Flat ribbon cable  | Terminal block box   | Electrical entry  | Circular connector  | SUP EXH port  | Cylinder port   |
| <p><b>D-sub connector</b><br/>(Compatible with D-sub connector that complies with MIL standard.)</p>  <p>25 pins<br/>IP40 compliant</p> | <p><b>Flat ribbon cable</b><br/>(Compatible with flat ribbon cable connector that complies with MIL standard.)</p>  <p>26 pins/20 pins<br/>IP40 compliant</p> | <p><b>Terminal block box</b><br/>(Terminal blocks)<br/>Terminals are concentrated in compact clusters within the terminal block box.</p>  <p>IP67 compliant</p> | <p><b>Lead wire</b><br/>(IP67 enclosure with use of multiple wire cable with sheath and waterproof connector)</p>  <p>IP67 compliant</p> | <p><b>Circular connector</b><br/>(IP67 enclosure with use of waterproof multiple connector)</p>  <p>IP67 compliant</p> | <p>1, 3<br/>(P, R)</p>  | <p>2, 4<br/>(A, B)</p>  |
| —   | —  | —  | —   | —   |   |   |
| <p>●<br/>Page 626</p>   | <p>●<br/>Page 628</p>  | <p>●<br/>Page 630</p>  | <p>●<br/>Page 632</p>   | <p>●<br/>Page 634</p>   | <p>&lt;SUP port&gt;<br/>1/2<br/>(Rc, NPT, NPTF, G)</p>  | <p>C6 (for ø6)<br/>C8 (for ø8)<br/>C10 (for ø10)<br/>C12 (for ø12)<br/>N7 (ø1/4")<br/>N9 (ø5/16")<br/>N11 (ø3/8")</p> |
| <p>●<br/>Page 664</p>   | <p>●<br/>Page 666</p>  | <p>●<br/>Page 668</p>  | <p>●<br/>Page 670</p>   | <p>●<br/>Page 672</p>   | <p>&lt;EXH port&gt;<br/>3/4<br/>(Rc, NPT, NPTF, G)</p>  | <p>1/4<br/>3/8<br/>1/4 (Bottom ported)<br/>(Rc, NPT, NPTF, G)</p>   |
| <p>●<br/>Page 664</p>   | <p>●<br/>Page 666</p>  | <p>●<br/>Page 668</p>  | <p>●<br/>Page 670</p>   | <p>●<br/>Page 672</p>   | <p>&lt;SUP port&gt;<br/>D side 1/2<br/>(Rc, NPT, NPTF, G)<br/>U side 3/8<br/>(Rc, NPT, NPTF, G)</p> | <p>3/8<br/>1/2<br/>1/2 (Bottom ported)<br/>(Rc, NPT, NPTF, G)</p>   |
| <p>●<br/>Page 664</p>   | <p>●<br/>Page 666</p>  | <p>●<br/>Page 668</p>  | <p>●<br/>Page 670</p>   | <p>●<br/>Page 672</p>   | <p>&lt;EXH port&gt;<br/>D side 1/2<br/>(Rc, NPT, NPTF, G)<br/>U side 3/8<br/>(Rc, NPT, NPTF, G)</p> | <p>3/8<br/>1/2<br/>1/2 (Bottom ported)<br/>(Rc, NPT, NPTF, G)</p>   |

- SV
- SYJ
- SZ
- VF
- VP4
- VQ 1/2
- VQ 4/5
- VQC 1/2
- VQC 4/5
- VQZ
- SQ
- VFS
- VFR
- VQ7

# Cylinder Speed Chart

## VQC4000

This chart is provided as guidelines only.  
For performance under various conditions, use SMC's Model Selection Software before making a judgment.

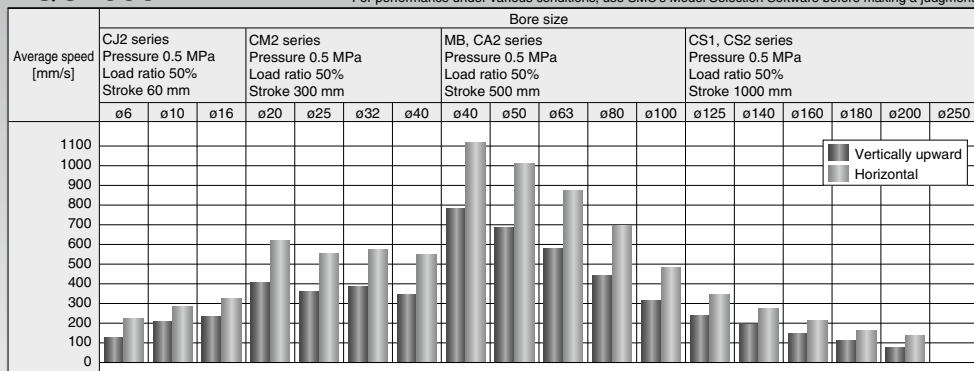

- \* Values at extension of a directly coupled cylinder when meter-out speed controllers are used with the needle full open.
- \* The average speed of the cylinder is obtained by dividing the stroke by the total stroke time.
- \* The load ratio is obtained by the following formula:  $((\text{Load mass} \times 9.8) / \text{Theoretical output}) \times 100\%$

### Conditions

| Base mounted     | CJ2 series  | CM2 series  | MB, CA2 series | CS1, CS2 series |
|------------------|-------------|-------------|----------------|-----------------|
| Tube x Length    | T0604 x 1 m | T1075 x 1 m | T1209 x 1 m    |                 |
| Speed controller | AS3002F-06  | AS4002F-10  | AS4002F-12     |                 |
| Silencer         | AN40-04     |             |                | AN40-04         |

### Conditions [With SGP (Steel Pipe)]

| Body ported      | MB, CA2 series | CS1, CS2 series |
|------------------|----------------|-----------------|
| Tube x Length    | SGP10A x 1 m   |                 |
| Speed controller | AS420-03       |                 |
| Silencer         | AN40-04        |                 |

## VQC5000

This chart is provided as guidelines only.  
For performance under various conditions, use SMC's Model Selection Software before making a judgment.

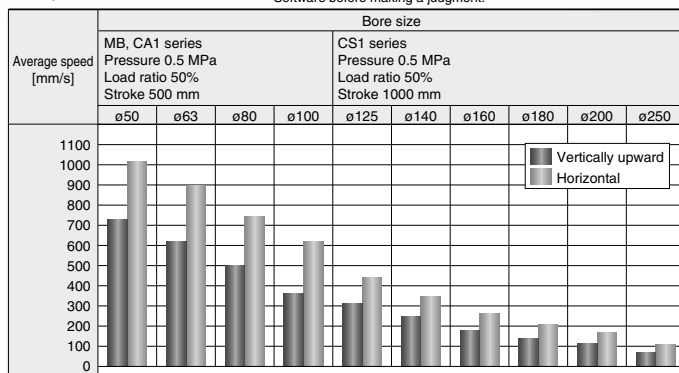

- \* Values at extension of a directly coupled cylinder when meter-out speed controllers are used with the needle full open.
- \* The average speed of the cylinder is obtained by dividing the stroke by the total stroke time.
- \* The load ratio is obtained by the following formula:  $((\text{Load mass} \times 9.8) / \text{Theoretical output}) \times 100\%$

### Conditions

| Speed controller | Silencer | SPG (Steel pipe) dia. x Length |
|------------------|----------|--------------------------------|
| AS420-04         | AN40-04  | 10A x 1 m                      |

# INDEX

|  |          |
|--|----------|
| Sub-plate/Base Mounted: Variations ..... | Page 606 |
| Cylinder Speed Chart .....               | Page 608 |

## VQC4000 Series

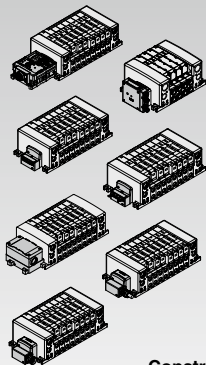

|  |          |
|--|----------|
| <b>Plug-in: Single Unit</b> .....  | Page 610 |
| <b>Plug-in Unit: Manifold</b> .....  | Page 614 |
| S Kit (Serial transmission kit): EX600 [IP67]/<br>EX500 [IP67]/EX260 [IP40/IP67]/<br>EX250 [IP67]/EX126 [IP67] ..... | Page 618 |
| F Kit (D-sub connector kit) [IP40] .....   | Page 626 |
| P Kit (Flat ribbon cable kit) [IP40] .....   | Page 628 |
| T Kit (Terminal block box kit) [IP67] .....  | Page 630 |
| L Kit (Lead wire kit) [IP67] .....   | Page 632 |
| M Kit (Circular connector kit) [IP67] .....  | Page 634 |
| <b>Construction</b> .....  | Page 636 |
| <b>Exploded View of Manifold</b> .....   | Page 637 |
| <b>Specific Product Precautions</b> .....  | Page 642 |

## VQC5000 Series

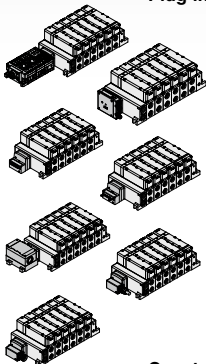

|  |          |
|--|----------|
| <b>Plug-in: Single Unit</b> .....  | Page 648 |
| <b>Plug-in Unit: Manifold</b> .....  | Page 652 |
| S Kit (Serial transmission kit): EX600 [IP67]/<br>EX500 [IP67]/EX260 [IP40/IP67]/<br>EX250 [IP67]/EX126 [IP67] ..... | Page 656 |
| F Kit (D-sub connector kit) [IP40] .....   | Page 664 |
| P Kit (Flat ribbon cable kit) [IP40] .....   | Page 666 |
| T Kit (Terminal block box kit) [IP67] .....  | Page 668 |
| L Kit (Lead wire kit) [IP67] .....   | Page 670 |
| M Kit (Circular connector kit) [IP67] .....  | Page 672 |
| <b>Construction</b> .....  | Page 674 |
| <b>Exploded View of Manifold</b> .....   | Page 675 |
| <b>Specific Product Precautions</b> .....  | Page 680 |

|         |
|---------|
| SV      |
| SYJ     |
| SZ      |
| VF      |
| VPA     |
| VQ 1/2  |
| VQ 4/5  |
| VQC 1/2 |
| VQC 4/5 |
| VQZ     |
| SQ      |
| VFS     |
| VFR     |
| VQ7     |

# Base Mounted

## Plug-in: Single Unit

# VQC4000 Series

### Model

| Series  | Configuration | Model           |             | Port size | Flow rate characteristics   |     |      |                             |     |      | Response time [ms] |                         | Weight [kg] |      |      |
|---------|---------------|-----------------|-------------|-----------|-----------------------------|-----|------|-----------------------------|-----|------|--------------------|-------------------------|-------------|------|------|
|         |               |                 |             |           | 1 → 4/2 (P → A/B)           |     |      | 4/2 → 5/3 (A/B → EA/EB)     |     |      | Standard: 0.95 W   | Low wattage type: 0.4 W |             |      |      |
|         |               |                 |             |           | C [dm <sup>3</sup> (s-bar)] | b   | Cv   | C [dm <sup>3</sup> (s-bar)] | b   | Cv   |                    |                         |             |      |      |
| VQC4000 | 2-position    | Single          | Metal seal  | VQC4100   | 3/8                         | 6.2 | 0.19 | 1.5                         | 6.9 | 0.17 | 1.7                | 20                      | 22          | 0.23 |      |
|         |               |                 | Rubber seal | VQC4101   |                             | 7.2 | 0.43 | 2.1                         | 7.3 | 0.38 | 2.0                | 25                      | 27          |      |      |
|         |               | Double          | Metal seal  | VQC4200   |                             | 6.2 | 0.19 | 1.5                         | 6.9 | 0.17 | 1.7                | 12                      | 16          |      | 0.26 |
|         |               |                 | Rubber seal | VQC4201   |                             | 7.2 | 0.43 | 2.1                         | 7.3 | 0.38 | 2.0                | 15                      | 17          |      |      |
|         | 3-position    | Closed center   | Metal seal  | VQC4300   |                             | 5.9 | 0.23 | 1.5                         | 6.3 | 0.18 | 1.6                | 45                      | 47          | 0.28 |      |
|         |               |                 | Rubber seal | VQC4301   |                             | 7.0 | 0.34 | 1.9                         | 6.4 | 0.42 | 1.9                | 50                      | 52          |      |      |
|         |               | Exhaust center  | Metal seal  | VQC4400   |                             | 6.2 | 0.18 | 1.5                         | 6.9 | 0.17 | 1.7                | 45                      | 47          | 0.28 |      |
|         |               |                 | Rubber seal | VQC4401   |                             | 7.0 | 0.38 | 1.9                         | 7.3 | 0.38 | 2.0                | 50                      | 52          |      |      |
|         |               | Pressure center | Metal seal  | VQC4500   |                             | 6.2 | 0.18 | 1.6                         | 6.4 | 0.18 | 1.6                | 45                      | 47          | 0.28 |      |
|         |               |                 | Rubber seal | VQC4501   |                             | 7.0 | 0.38 | 1.9                         | 7.1 | 0.38 | 2.0                | 50                      | 52          |      |      |
|         |               | Double check    | Metal seal  | VQC4600   |                             | 2.7 | —    | —                           | 3.7 | —    | —                  | 55                      | 57          | 0.50 |      |
|         |               |                 | Rubber seal | VQC4601   |                             | 2.8 | —    | —                           | 3.9 | —    | —                  | 62                      | 64          |      |      |

Note 1) Cylinder port 3/8: Value for valve on sub-plate

Note 2) Based on JIS B 8419: 2010. (Supply pressure: 0.5 MPa, with indicator light and surge voltage suppressor, clean air. This will change depending on pressure and air quality.) The value when ON for the double type.

Note 3) Table: Without sub-plate, With sub-plate: Add 0.41 kg.



Plug-in unit

### Symbol

2-position single

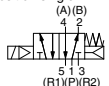

2-position double (Metal)

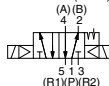

2-position double (Rubber)

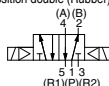

3-position closed center

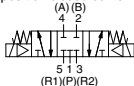

3-position exhaust center

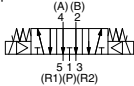

3-position pressure center

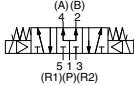

3-position double check

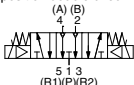

### Standard Specifications

| Valve specifications          | Valve construction   | Metal seal            | Rubber seal |
|-------------------------------|--|-----------------------|-------------|
|                               | Fluid  | Air/Inert gas         |             |
| Max. operating pressure       | 1.0 MPa  |                       |             |
| Min. operating pressure       | Single   | 0.15 MPa              | 0.20 MPa    |
|                               | Double<br>3-position   | 0.15 MPa              |             |
| Ambient and fluid temperature | -10 to 50°C (Note 1)   |                       |             |
| Lubrication                   | Not required   |                       |             |
| Manual override               | Push type/Locking type (Tool required)/Locking type (Manual) |                       |             |
| Impact/Vibration resistance   | 150/30 m/s <sup>2</sup> (Note 2)                             |                       |             |
| Enclosure                     | Dust-tight (IP67 compatible) (Note 3)                        |                       |             |
| Electrical specifications     | Coil rated voltage   | 12, 24 VDC            |             |
|                               | Allowable voltage fluctuation                                | ±10% of rated voltage |             |
|                               | Coil insulation type   | Class B or equivalent |             |
|                               | Power consumption [W]  | 24 VDC                | 0.95, 0.4   |
| 12 VDC                        |  | 0.95, 0.4             |             |

Note 1) Use dry air to prevent condensation when operating at low temperatures.

Note 2) Impact resistance: No malfunction occurred when it is tested with a drop tester in the axial direction and at the right angles to the main valve and armature in both energized and de-energized states every once for each condition. (Values at the initial period)

Vibration resistance: No malfunction occurred in a one-sweep test between 45 and 2000 Hz. Test was performed at both energized and de-energized states in the axial direction and at the right angles to the main valve and armature. (Values at the initial period)

Note 3) Only applicable to S, T, L and M kits



How to Order Valves

**Plug-in** **VQC4** **1** **0** **0** - - - **1** - - -

**Type of actuation**

|   |  |   |
|---|--|---|
| 1 | 2-position single<br>(A)(B)<br>4 2<br>1 3<br>(R1)(P)(R2) | 3-position closed center<br>(A)(B)<br>4 2<br>5 1 3<br>(R1)(P)(R2)   |
|   | 2-position double<br>(A)(B)<br>4 2<br>1 3<br>(R1)(P)(R2) | 3-position exhaust center<br>(A)(B)<br>4 2<br>5 1 3<br>(R1)(P)(R2)  |
| 2 | 2-position double<br>(A)(B)<br>4 2<br>1 3<br>(R1)(P)(R2) | 3-position pressure center<br>(A)(B)<br>4 2<br>5 1 3<br>(R1)(P)(R2) |
|   | 2-position double<br>(A)(B)<br>4 2<br>1 3<br>(R1)(P)(R2) | 3-position double check<br>(A)(B)<br>4 2<br>5 1 3<br>(R1)(P)(R2)    |

Note) For double check type, refer to page 478 of the VQ4000/5000 series.

**Thread type**

|     |      |
|-----|------|
| Nil | Rc   |
| N   | NPT  |
| T   | NPTF |
| F   | G    |

**Port size**

|     |                                  |
|-----|----------------------------------|
| Nil | Without sub-plate (For manifold) |
| 02  | 1/4                              |
| 03  | 3/8                              |

**Porting specifications**

|     |               |
|-----|---------------|
| Nil | Side ported   |
| B   | Bottom ported |

**Manual override**

**Nil:** Non-locking push type (Tool required)

**B:** Locking type (Tool required)

**C:** Locking type (Manual)

**Light/Surge voltage suppressor**

|     |  |
|-----|--|
| Nil | Yes  |
| E   | Without light, with surge voltage suppressor |

**Coil voltage**

|   |        |
|---|--------|
| 5 | 24 VDC |
| 6 | 12 VDC |

**Seal**

|   |             |
|---|-------------|
| 0 | Metal seal  |
| 1 | Rubber seal |

**Function**

|              |                          |
|--------------|--------------------------|
| Nil (Note 1) | Standard (0.95 W)        |
| Y            | Low wattage type (0.4 W) |
| R (Note 2)   | External pilot           |

**0: Plug-in sub-plate**

Note 1) When the power is energized continuously, refer to "Specific Product Precautions 1" on page 642.

Note 2) For details about external pilot type, refer to page 481 of the VQ4000/5000 series. In addition, external pilot type cannot be combined with a double check spacer.

Note 3) When multiple symbols are specified, indicate them alphabetically.

SV

SYJ

SZ

VF

VP4

VQ 1/2

VQ 4/5

VQC 1/2

VQC 4/5

VQZ

SQ

VFS

VFR

VQ7



How to Order Sub-plates

**VQ4000 - PW -** - **02** - - -

**Porting specifications**

|     |                      |
|-----|----------------------|
| Nil | Side ported          |
| B   | Bottom ported (Note) |

**Port size**

|    |     |
|----|-----|
| 02 | 1/4 |
| 03 | 3/8 |

Note) For bottom ported, port size is 1/4 only.

**Thread type**

|     |      |
|-----|------|
| Nil | Rc   |
| N   | NPT  |
| T   | NPTF |
| F   | G    |

**CE-compliant**

|     |              |
|-----|--------------|
| Nil | -            |
| Q   | CE-compliant |

**Replacement of pilot valve assembly (Voltage)**

- Refer to page 640 for pilot valve assembly part numbers.
- Refer to page 643 for replacement method.



# VQC4000 Series

## Dimensions: Plug-in Type

### Conduit terminal

#### 2-position single: VQC410<sup>0</sup>-□

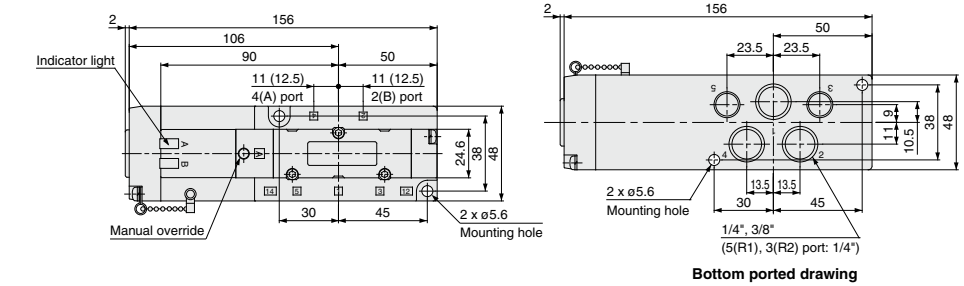

( ) : Values for 3/8"

#### 2-position double: VQC420<sup>0</sup>-□

#### 3-position closed center: VQC430<sup>0</sup>-□

#### 3-position exhaust center: VQC440<sup>0</sup>-□

#### 3-position pressure center: VQC450<sup>0</sup>-□

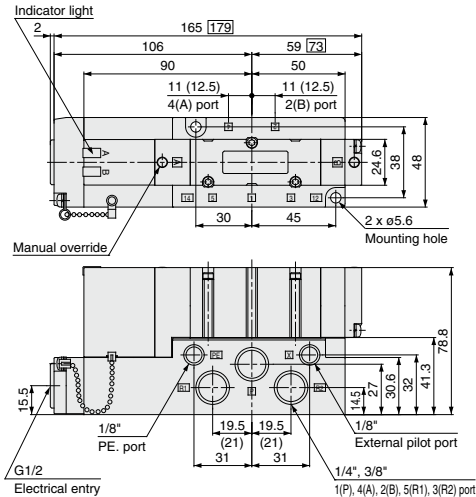

#### 3-position double check: VQC460<sup>0</sup>-□

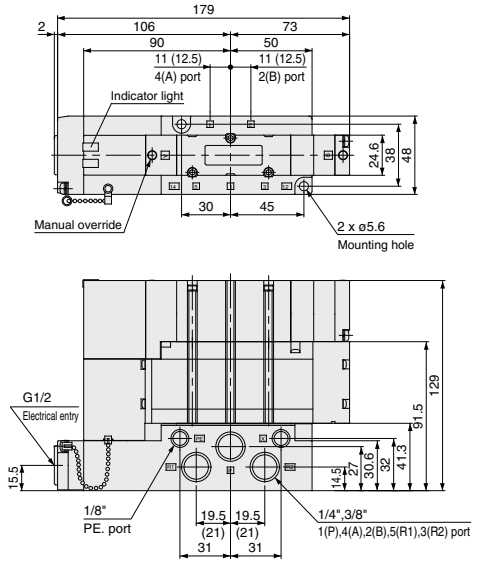

□ : Values for 3-position  
( ) : Values for 3/8"



**4 Kit type/Electrical entry/Cable length**

\* The number in parentheses indicates the maximum number of stations and the maximum number of solenoids that can be used in the case of mixed single and double wiring. The total number of solenoids determines the maximum number of stations. When ordering mixed wiring, please add the option symbol "K".

**S** Kit  
(Serial transmission kit (Fieldbus system)  
: EX600 integrated-type (for I/O))

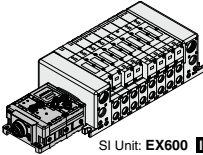

SI Unit: EX600 IP67 compliant

|       |   |                  |                          |
|-------|---|------------------|--------------------------|
| SD60  | Serial kit without SI Unit                              |                  |                          |
| SD6Q  | DeviceNet™  |                  |                          |
| SD6N  | PROFIBUS DP   |                  |                          |
| SD6V  | CC-Link   |                  |                          |
| SD6F  | PROFINET  |                  |                          |
| SD6ZE | EtherNet/IP™ (1 port)                                   | 1 to 12 stations | (16 stations, 24 points) |
| SD6EA | EtherNet/IP™ (2 port)                                   |                  |                          |
| SD6D  | EtherCAT  |                  |                          |
| SD6WE | EtherNet/IP™ compatible wireless base <sup>Non 5)</sup> |                  |                          |
| SD6EA | PROFINET compatible wireless base <sup>Non 5)</sup>     |                  |                          |
| SD6WS | Wireless remote <sup>Note 5)</sup>                      |                  |                          |

**S** Kit  
(Serial transmission kit: EX500 gateway-type)

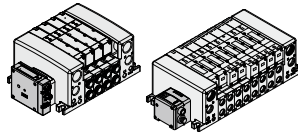

SI Unit: EX500

Note) A separate Gateway Unit and communication cable are required. IP67 compliant

|      |  |                              |  |
|------|--|------------------------------|--|
| SD0A | Serial kit without SI Unit   | —                            | —  |
| SDA3 | EX500 Gateway Decentralized System 2 (128 points)<br>EtherNet/IP™, PROFINET                | 32 outputs <sup>Non 1)</sup> | 1 to 12 stations<br>(16 stations, 24 points) |
| SDA2 | EX500 Gateway Decentralized System (64 points)<br>DeviceNet™, PROFIBUS DP,<br>EtherNet/IP™ | 16 outputs                   | 1 to 8 stations<br>(16 stations, 16 points)  |

**S** Kit  
(Serial transmission kit: EX260 integrated-type (for output))

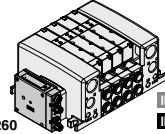

SI Unit: EX260

IP40 compliant

IP67 compliant

| Symbol | Protocol                   | Number of outputs | Communication connector  | Stations                                     |
|--------|----------------------------|-------------------|--------------------------|--|
| SD0A   | Serial kit without SI Unit |                   |                          | 1 to 12 stations<br>(16 stations, 24 points) |
| SQA    | DeviceNet™                 | 32                | M12                      | 1 to 8 stations (16 stations, 16 points)     |
| SQB    |                            | 16                |                          | 1 to 4 stations (8 stations, 4 points)       |
| SNA    |                            | 32                | M12                      | 1 to 8 stations (16 stations, 24 points)     |
| SNB    |                            | 16                |                          | 1 to 4 stations (8 stations, 4 points)       |
| SNC    | PROFIBUS DP                | 32                |                          | 1 to 8 stations (16 stations, 24 points)     |
| SND    |                            | 16                | D-sub <sup>Note 3)</sup> | 1 to 8 stations (16 stations, 16 points)     |
| SVA    |                            | 32                |                          | 1 to 12 stations (16 stations, 24 points)    |
| SVB    |                            | 16                |                          | 1 to 8 stations (16 stations, 16 points)     |
| SDA    | CC-Link                    | 32                | M12                      | 1 to 12 stations (16 stations, 24 points)    |
| SDB    |                            | 16                |                          | 1 to 8 stations (16 stations, 16 points)     |
| SDF    | EtherCAT                   | 32                | M12                      | 1 to 12 stations (16 stations, 24 points)    |
| SDE    |                            | 16                |                          | 1 to 8 stations (16 stations, 16 points)     |
| SFA    | PROFINET                   | 32                | M12                      | 1 to 12 stations (16 stations, 24 points)    |
| SFB    |                            | 16                |                          | 1 to 8 stations (16 stations, 16 points)     |
| SEA    | EtherNet/IP™               | 32                | M12                      | 1 to 12 stations (16 stations, 24 points)    |
| SEB    |                            | 16                |                          | 1 to 8 stations (16 stations, 16 points)     |
| SGA    | Ethernet                   | 32                | M12                      | 1 to 12 stations (16 stations, 24 points)    |
| SGB    | POWERLINK                  | 16                |                          | 1 to 8 stations (16 stations, 16 points)     |
| SKA    | IO-Link                    | 32                | M12                      | 1 to 12 stations (16 stations, 24 points)    |

**S** Kit  
(Serial transmission kit: EX250 integrated-type (for I/O))

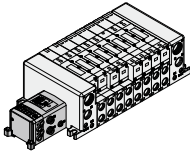

SI Unit: EX250

IP67 compliant

|                         |  |  |  |
|-------------------------|--|--|--|
| SD0                     | Serial kit without SI Unit                                     |  | 1 to 12 stations<br>(16 stations, 24 points) |
| SDQ                     | DeviceNet™   |  |  |
| SDN                     | PROFIBUS DP  |  |  |
| SDTA                    | AS-Interface, 8 in/out, 31 slave modes, 2 power supply systems |  | 1 to 4 stations (8 stations, 8 points)       |
| SDTB                    | AS-Interface, 4 in/out, 31 slave modes, 2 power supply systems |  | 1 to 2 stations (4 stations, 4 points)       |
| SDTC <sup>Note 2)</sup> | AS-Interface, 8 in/out, 31 slave modes, 1 power supply system  |  | 1 to 4 stations (8 stations, 8 points)       |
| SDTD <sup>Note 2)</sup> | AS-Interface, 4 in/out, 31 slave modes, 1 power supply system  |  | 1 to 2 stations (4 stations, 4 points)       |
| SDY                     | CANopen  |  | 1 to 12 stations<br>(16 stations, 24 points) |
| SDZEN                   | EtherNet/IP™   |  |  |

**S** Kit  
(Serial transmission kit: EX126 integrated-type (for output))

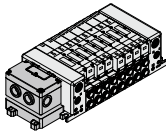

SI Unit: EX126

IP67 compliant

|      |                        |  |
|------|------------------------|--|
| SDVB | Serial kit for CC-Link | 1 to 8 stations (16 stations, 16 points) |
|------|------------------------|--|

**F** Kit  
(D-sub connector kit)

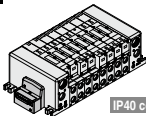

IP40 compliant

|     |  |                  |
|-----|--|------------------|
| FD0 | D-sub connector kit (25P) without cable    | 4 to 12 stations |
| FD1 | D-sub connector kit (25P) with 1.5 m cable | 16 stations      |
| FD2 | D-sub connector kit (25P) with 3.0 m cable | 24 points        |
| FD3 | D-sub connector kit (25P) with 5.0 m cable |                  |

**M** Kit  
(Circular connector kit)

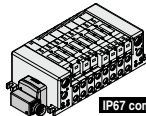

IP67 compliant

|     |   |                  |
|-----|---|------------------|
| MD0 | Circular connector kit (26P) without cable    | 1 to 12 stations |
| MD1 | Circular connector kit (26P) with 1.5 m cable | 16 stations      |
| MD2 | Circular connector kit (26P) with 3.0 m cable | 24 points        |
| MD3 | Circular connector kit (26P) with 5.0 m cable |                  |

**P** Kit  
(Flat ribbon cable kit)

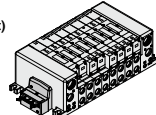

IP40 compliant

Note) For a 20P flat ribbon cable, the cable assembly must be ordered separately.

|     |  |  |
|-----|--|--|
| PD0 | Flat ribbon cable kit (26P) without cable                    |  |
| PD1 | Flat ribbon cable kit (26P) with 1.5 m cable                 | 1 to 12 stations                         |
| PD2 | Flat ribbon cable kit (26P) with 3.0 m cable                 | (16 stations, 24 points)                 |
| PD3 | Flat ribbon cable kit (26P) with 5.0 m cable                 |  |
| PDC | Flat ribbon cable kit (20P) without cable <sup>Note 4)</sup> | 1 to 9 stations (16 stations, 18 points) |

**T** Kit  
(Terminal block box kit)

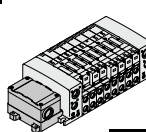

IP67 compliant

|     |                        |  |
|-----|------------------------|--|
| TD0 | Terminal block box kit | 1 to 10 stations<br>(16 stations, 20 points) |
|-----|------------------------|--|

**L** Kit  
(Lead wire kit)

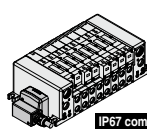

IP67 compliant

|     |                                |                          |
|-----|--------------------------------|--------------------------|
| LD0 | Lead wire kit, 0.6 m lead wire | 1 to 12 stations         |
| LD1 | Lead wire kit, 1.5 m lead wire | (16 stations, 24 points) |
| LD2 | Lead wire kit, 3.0 m lead wire | (24 points)              |

\* The maximum number of stations and the maximum number of solenoids indicated in parentheses are applied to special wiring specifications only (Option "K").

Note 1) When using the SI Unit with 32 outputs, use the GW Unit compatible with the EX500 Gateway Decentralized System 2 (128 points).

Note 2) When selecting SI Units with SDTC or SDTD specifications, there are limits to the supply current from the SI Unit to the input block or valve. For details, refer to page 805 in Best Pneumatics No. 1-1.

Note 3) When selecting D-sub 5 kit specifications only, IP40 is compatible. (All other SI Units are IP67 compliant.)

Note 4) For the SI Unit part no., refer to page 617.  
Note 5) The wireless system is suitable for use only in a country where it is in accordance with the Radio Act and regulations of that country.

SV  
SYJ  
SZ  
VF  
VP4  
VQ 1/2  
VQ 4/5  
VQC 1/2  
VQC 4/5  
VQZ  
SQ  
VFS  
VFR  
VQ7

# VQC4000 Series

## How to Order Valves

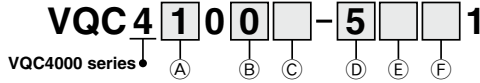

### (A) Type of actuation

|   |  |   |  |
|---|--|---|--|
| 1 | 2-position single<br>(A) (B)<br><br>(R1) (P) (R2)          | 4 | 3-position exhaust center<br>(A) (B)<br><br>(R1) (P) (R2)  |
|   | 2-position double (Metal)<br>(A) (B)<br><br>(R1) (P) (R2)  |   | 3-position pressure center<br>(A) (B)<br><br>(R1) (P) (R2) |
| 2 | 2-position double (Rubber)<br>(A) (B)<br><br>(R1) (P) (R2) | 6 | 3-position double check<br>(A) (B)<br><br>(R1) (P) (R2)    |
|   | 3-position closed center<br>(A) (B)<br><br>(R1) (P) (R2)   |   |  |

### (B) Seal type

|   |             |
|---|-------------|
| 0 | Metal seal  |
| 1 | Rubber seal |

### (C) Function

|                        |                          |
|------------------------|--------------------------|
| Nil <sup>Note 1)</sup> | Standard (0.95 W)        |
| Y                      | Low wattage type (0.4 W) |
| R <sup>Note 2)</sup>   | External pilot           |

Note 1) When the power is energized continuously, refer to "Specific Product Precautions 1" on page 642.

Note 2) For details about external pilot type, refer to page 481 of the VQ4000/5000 series.

\* When multiple symbols are specified, indicate them alphabetically.

### (D) Coil voltage

|   |                         |
|---|-------------------------|
| 5 | 24 VDC <sup>Note)</sup> |
| 6 | 12 VDC                  |

Note) S kit is only available for 24 VDC.

### (E) Light/Surge voltage suppressor

|     |  |
|-----|--|
| Nil | Yes  |
| E   | Without light, with surge voltage suppressor |

### (F) Manual override

|     |  |
|-----|--|
| Nil | Non-locking push type (Tool required)<br>  |
| B   | Push-turn locking type (Tool required)<br> |
| C   | Turn locking type (Manual)<br>             |

## How to Order Manifold Assembly

### Example (VV5QC41-□SD6□)

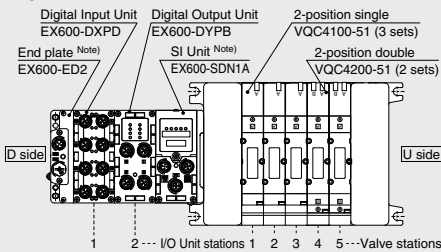

VV5QC41-0502SD6Q2N2---1 set (S kit 5-station manifold base part number)  
 \*VQC4100-51-.....3 sets (2-position single part number)  
 \*VQC4200-51-.....2 sets (2-position double part number)  
 \*EX600-DXPD-.....1 set I/O Unit part number (Station 1)  
 \*EX600-DYPB-.....1 set I/O Unit part number (Station 2)

\* The asterisk denotes the symbol for assembly.  
 \* Prefix it to the part numbers of the valve etc.

· The valve arrangement is numbered as the 1st station from the D side.  
 · Under the manifold part number, state the valves to be mounted, then the I/O Unit in order from the 1st station as shown in the figure above. If the arrangement becomes complicated, specify on a manifold specification sheet.

Note) Do not enter the SI Unit part number and the end plate part number together.

## Manifold Specifications

| Series  | Base model  | Connection type  | Piping specifications |                              | Note 2) Applicable stations   | Applicable solenoid valve   | 5-station weight [g]     |  |
|---------|-------------|--|-----------------------|------------------------------|---|---|--------------------------|--|
|         |             |  | Port direction        | Port size <sup>Note 1)</sup> |   |   |                          |  |
| VQC4000 | VV5QC41-□□□ | ■ F kit: D-sub connector<br>■ P kit: Flat ribbon cable<br>■ T kit: Terminal block box<br>■ S kit: Serial transmission<br>■ L kit: Lead wire<br>■ M kit: Circular connector | Side                  | P: 1/2<br>(Rc, G, NPT/NPTF)  | 2, 4 (A, B)<br>C6 (for ø6)<br>C8 (for ø8)<br>C10 (for ø10)<br>C12 (for ø12) | ( F, L, M, P kit<br>1 to 12 stations)<br>T kit<br>( 1 to 10 stations)<br>S kit<br>( 1 to 12 stations: EX250<br>1 to 12 stations: EX300) | VQC4□00-51<br>VQC4□01-51 | 2282<br>S kit<br>(Without Unit)<br>Not including valve weight. |
|         |             |  |                       | R: 3/4<br>(Rc, G, NPT/NPTF)  | 3/8 (Rc, G, NPT/NPTF)   |   |                          |  |
|         |             |  |                       | Bottom                       | 1/4<br>(Rc, G, NPT/NPTF)  |   |                          |  |

Note 1) One-touch fittings in inch sizes are also available.

Note 2) An optional specification for special wiring is available to increase the maximum number of stations.

SI Unit Part Number Table

| EX600 Integrated type (For Input/Output) |  |                       |                       |      |
|--|--|-----------------------|-----------------------|------|
| Symbol                                   | Applicable protocol                                    | SI Unit part no.      |                       | Page |
|  |  | Negative common (PNP) | Positive common (NPN) |      |
| SD6Q                                     | DeviceNet™   | EX600-SDN1A           | EX600-SDN2A           | 638  |
| SD6N                                     | PROFIBUS DP  | EX600-SPR1A           | EX600-SPR2A           |      |
| SD6V                                     | CC-Link  | EX600-SMJ1            | EX600-SMJ2            |      |
| SD6F                                     | PROFINET   | EX600-SPN1            | EX600-SPN2            |      |
| SD6ZE                                    | EtherNet/IP™ (1 port)                                  | EX600-SEN1            | EX600-SEN2            |      |
| SD6EA                                    | EtherNet/IP™ (2 port)                                  | EX600-SEN3            | EX600-SEN4            |      |
| SD6D                                     | EtherCAT   | EX600-SEC1            | EX600-SEC2            |      |
| SD6WE                                    | EtherNet/IP™ compatible wireless base <sup>Note)</sup> | EX600-WEN1            | EX600-WEN2            |      |
| SD6WF                                    | PROFINET compatible wireless base <sup>Note)</sup>     | EX600-WPN1            | EX600-WPN2            |      |
| SD6WS                                    | Wireless remote <sup>Note)</sup>                       | EX600-WSV1            | EX600-WSV2            |      |

Note) The wireless system is suitable for use only in a country where it is in accordance with the Radio Act and regulations of that country.

| EX260 Integrated type (For Output) |                     |                   |                       |                       |                         |      |
|------------------------------------|---------------------|-------------------|-----------------------|-----------------------|-------------------------|------|
| Symbol                             | Applicable protocol | Number of outputs | SI Unit part no.      |                       | Communication connector | Page |
|                                    |                     |                   | Negative common (PNP) | Positive common (NPN) |                         |      |
| SQA                                | DeviceNet™          | 32                | EX260-SDN1            | EX260-SDN2            | M12                     | 638  |
| SQB                                |                     | 16                | EX260-SDN3            | EX260-SDN4            |                         |      |
| SNA                                | 32                  | EX260-SPR1        | EX260-SPR2            |                       |                         |      |
| SNB                                | 16                  | EX260-SPR3        | EX260-SPR4            |                       |                         |      |
| SNC                                | PROFIBUS DP         | 32                | EX260-SPR5            | EX260-SPR6            | D-sub                   |      |
| SND                                |                     | 16                | EX260-SPR7            | EX260-SPR8            |                         |      |
| SVA                                | CC-Link             | 32                | EX260-SMJ1            | EX260-SMJ2            | M12                     |      |
| SVB                                |                     | 16                | EX260-SMJ3            | EX260-SMJ4            |                         |      |
| SDA                                | EtherCAT            | 32                | EX260-SEC1            | EX260-SEC2            | M12                     |      |
| SDB                                |                     | 16                | EX260-SEC3            | EX260-SEC4            |                         |      |
| SFA                                | PROFINET            | 32                | EX260-SPN1            | EX260-SPN2            | M12                     |      |
| SFB                                |                     | 16                | EX260-SPN3            | EX260-SPN4            |                         |      |
| SEA                                | EtherNet/IP™        | 32                | EX260-SEN1            | EX260-SEN2            | M12                     |      |
| SEB                                |                     | 16                | EX260-SEN3            | EX260-SEN4            |                         |      |
| SGA                                | Ethernet POWERLINK  | 32                | EX260-SPL1            | —                     | M12                     |      |
| SGB                                |                     | 16                | EX260-SPL3            | —                     |                         |      |
| SKA                                |                     | IO-Link           | 32                    | EX260-SIL1            |                         | —    |

Manifold Options

Blanking plate assembly  
VVQ4000-10A-1

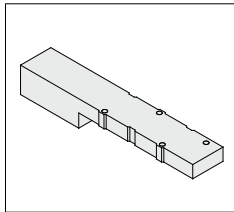

Individual SUP spacer  
VVQ4000-P-1-<sup>02</sup>/<sub>03</sub>

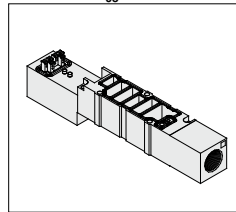

Individual EXH spacer  
VVQ4000-R-1-<sup>02</sup>/<sub>03</sub>

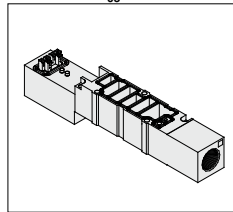

SUP/EXH block plate  
VVQ4000-16A (1 pc./set)

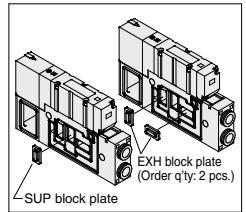

Restrictor spacer  
VVQ4000-20A-1

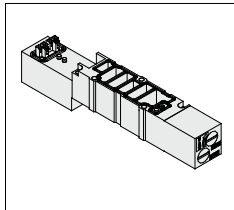

Double check spacer with residual pressure exhaust  
VVQ4000-25A-1 <sup>Note)</sup>

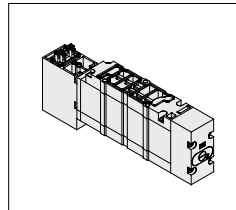

SUP stop valve spacer  
VVQ4000-37A-1

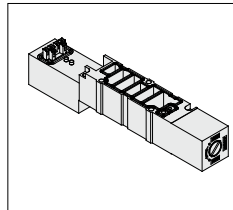

Interface regulator (P, A, B port regulation)  
ARBQ4000-00-β-1

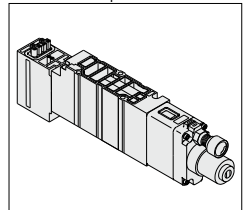

Note) The double check spacer with residual pressure release valve cannot be combined with external pilot type.

For replacement parts, refer to page 640.

| EX126 Integrated type (For Output) |                                |                  |      |
|------------------------------------|--------------------------------|------------------|------|
| Symbol                             | Applicable protocol            | SI Unit part no. | Page |
| SDVB                               | CC-Link, Positive common (NPN) | EX126D-SMJ1      | 639  |

| EX500 Gateway Decentralized System 2 (128 points) |                          |                       |  |      |
|---|--------------------------|-----------------------|--|------|
| Symbol  | Applicable protocol      | SI Unit part no.      |  | Page |
|   |                          | Negative common (PNP) |  |      |
| SDA3  | EtherNet/IP™<br>PROFINET | EX500-S103            |  | 638  |

| EX500 Gateway Decentralized System (64 points) |   |                       |                       |      |
|--|---|-----------------------|-----------------------|------|
| Symbol   | Applicable protocol                       | SI Unit part no.      |                       | Page |
|  |   | Positive common (NPN) | Negative common (PNP) |      |
| SDA2   | DeviceNet™<br>PROFIBUS DP<br>EtherNet/IP™ | EX500-Q001            | EX500-Q101            | 638  |

| EX250 Integrated type (For Input/Output) |   |                  |      |
|--|---|------------------|------|
| Symbol                                   | Applicable protocol   | SI Unit part no. | Page |
| SDQ                                      | DeviceNet™, Negative common (PNP)   | EX250-SDN1       | 639  |
| SDN                                      | PROFIBUS DP, Negative common (PNP)  | EX250-SPR1       |      |
| SDTA                                     | AS-Interface, Negative common (PNP), (8 in/8 out, 31 slave modes, 2 power supply systems) | EX250-SAS3       | 639  |
| SDTB                                     | AS-Interface, Negative common (PNP), (4 in/4 out, 31 slave modes, 2 power supply systems) | EX250-SAS5       |      |
| SDTC                                     | AS-Interface, Negative common (PNP), (8 in/8 out, 31 slave modes, 1 power supply system)  | EX250-SAS7       |      |
| SDTD                                     | AS-Interface, Negative common (PNP), (4 in/4 out, 31 slave modes, 1 power supply system)  | EX250-SAS9       | 639  |
| SDY                                      | CANopen, Negative common (PNP)  | EX250-SCA1A      |      |
| SDZEN                                    | EtherNet/IP™, Negative common (PNP)   | EX250-SEN1       |      |

For details about the EX series (Serial Transmission System), refer to Best Pneumatics No. 1-1 and the Operation Manual. Please download the Operation Manual via SMC website, <http://www.smcworld.com>

For details about options, refer to page 476 or later of the VQ4000 series.

# VQC4000 Series

## S VQC4000

Kit (Serial transmission kit): For EX600 Integrated-type (I/O) Serial Transmission System **IP67 compliant**

VV5QC41

S kit (Serial transmission kit: EX600)

Power supply with M12 connector

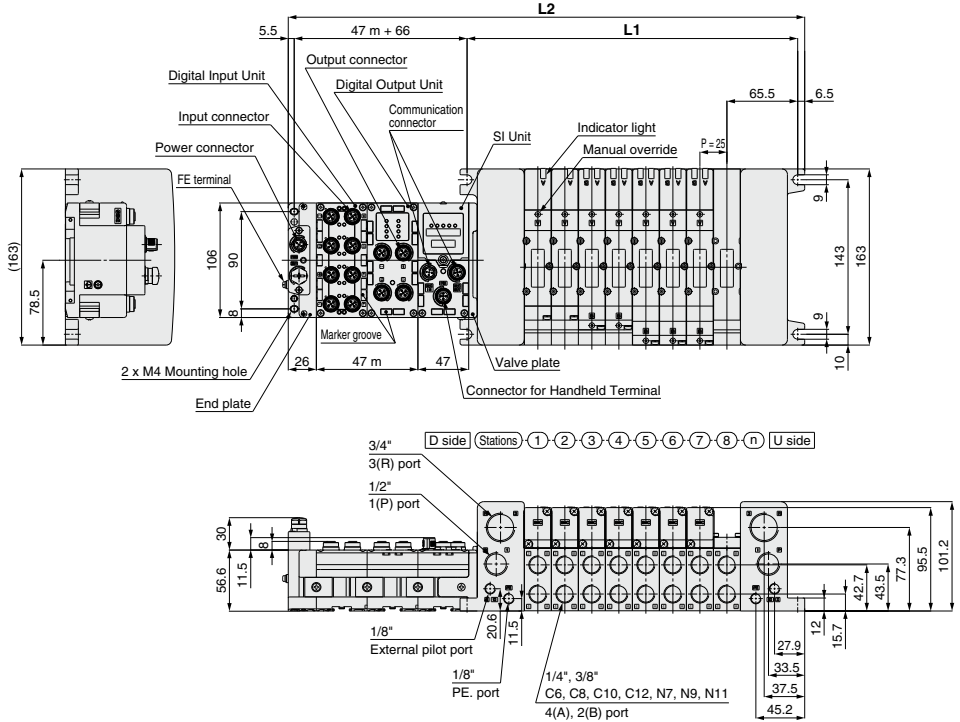

### Bottom ported

<P/R port side>

<Bottom side>

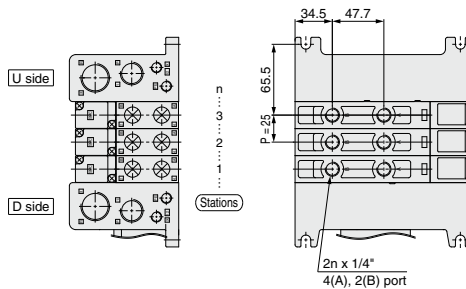

\* Other dimensions are the same as the side ported type.

### Dimensions

Formula:  $L1 = 25n + 106$ ,  $L2 = 25n + 184$  +  $L2$  is the dimension without I/O Unit. Add 47 mm for each additional I/O Units. \* "m" is number of I/O Units. n: Stations (Maximum 16 stations)

| L  | n | 1   | 2   | 3   | 4   | 5   | 6   | 7   | 8   | 9   | 10  | 11  | 12  | 13  | 14  | 15  | 16  |
|----|---|-----|-----|-----|-----|-----|-----|-----|-----|-----|-----|-----|-----|-----|-----|-----|-----|
| L1 |   | 131 | 156 | 181 | 206 | 231 | 256 | 281 | 306 | 331 | 356 | 381 | 406 | 431 | 456 | 481 | 506 |
| L2 |   | 209 | 234 | 259 | 284 | 309 | 334 | 359 | 384 | 409 | 434 | 459 | 484 | 509 | 534 | 559 | 584 |



VQC4000

Kit (Serial transmission kit): For EX600 Integrated-type (I/O) Serial Transmission System IP67 compliant

VV5QC41

S kit (Serial transmission kit: EX600)

Power supply with 7/8 inch connector

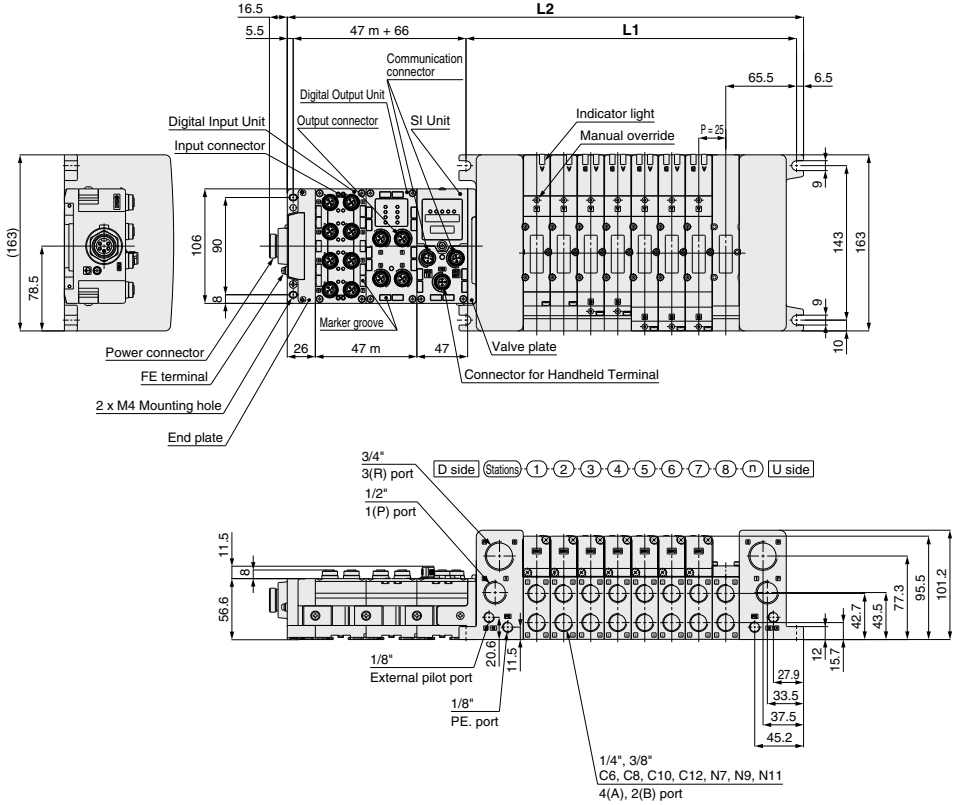

Note) The dimensions of the bottom ported type are common to all S kits.

Dimensions

Formula: L1 = 25n + 106, L2 = 25n + 184 \* L2 is the dimension without I/O Unit. Add 47 mm for each additional I/O Units. \* "n" is number of I/O Units. n: Stations (Maximum 16 stations)

| L  | n | 1   | 2   | 3   | 4   | 5   | 6   | 7   | 8   | 9   | 10  | 11  | 12  | 13  | 14  | 15  | 16  |
|----|---|-----|-----|-----|-----|-----|-----|-----|-----|-----|-----|-----|-----|-----|-----|-----|-----|
| L1 |   | 131 | 156 | 181 | 206 | 231 | 256 | 281 | 306 | 331 | 356 | 381 | 406 | 431 | 456 | 481 | 506 |
| L2 |   | 209 | 234 | 259 | 284 | 309 | 334 | 359 | 384 | 409 | 434 | 459 | 484 | 509 | 534 | 559 | 584 |

- SV
- SYJ
- SZ
- VF
- VP4
- VQ 1/2
- VQ 4/5
- VQC 1/2
- VQC 4/5
- VQZ
- SQ
- VFS
- VFR
- VQ7

# VQC4000 Series

## S VQC4000

Kit (Serial transmission kit): For EX500 Gateway Decentralized System 2 (128 points) IP67 compliant

VV5QC41

S kit (Serial transmission kit: EX500)

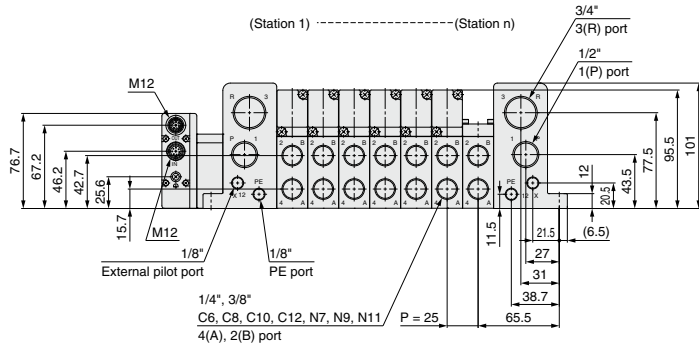
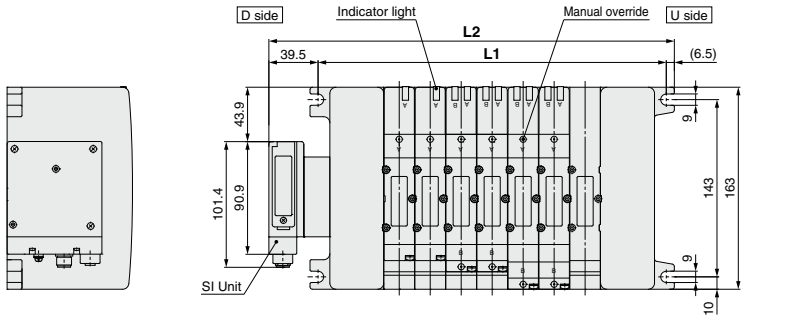

Note) The dimensions of the bottom ported type are common to all S kits.

Formula:  $L1 = 25n + 106$ ,  $L2 = 25n + 152$  n: Stations (Maximum 16 stations)

| n  | 1   | 2   | 3   | 4   | 5   | 6   | 7   | 8   | 9   | 10  | 11  | 12  | 13  | 14  | 15  | 16  |
|----|-----|-----|-----|-----|-----|-----|-----|-----|-----|-----|-----|-----|-----|-----|-----|-----|
| L1 | 131 | 156 | 181 | 206 | 231 | 256 | 281 | 306 | 331 | 356 | 381 | 406 | 431 | 456 | 481 | 506 |
| L2 | 177 | 202 | 227 | 252 | 277 | 302 | 327 | 352 | 377 | 402 | 427 | 452 | 477 | 502 | 527 | 552 |



**VQC4000**

Kit (Serial transmission kit): For EX500 Gateway Decentralized System (64 points) **IP67 compliant**

VV5QC41

S kit (Serial transmission kit: EX500)

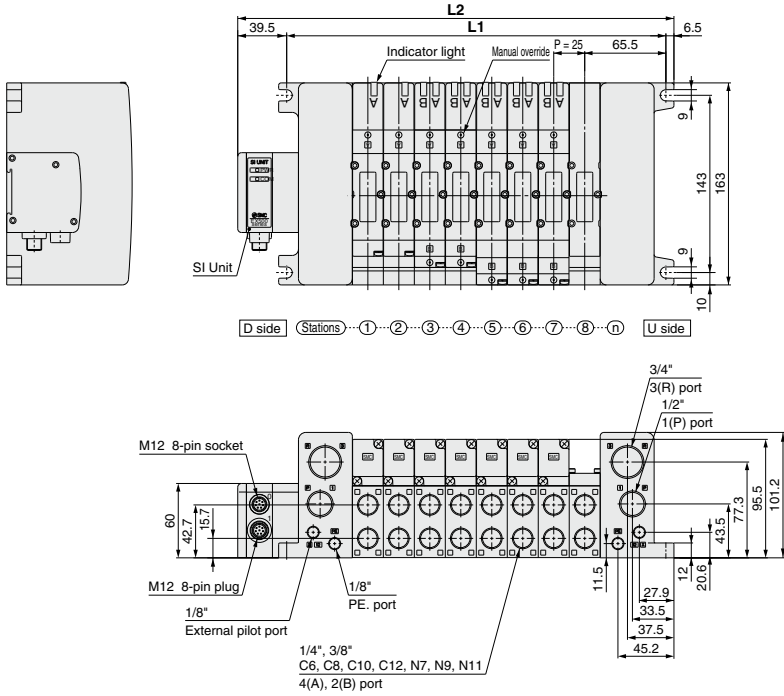

- SV
- SYJ
- SZ
- VF
- VP4
- VQ 1/2
- VQ 4/5
- VQC 1/2
- VQC 4/5**
- VQZ
- SQ
- VFS
- VFR
- VQ7

Note) The dimensions of the bottom ported type are common to all S kits.

**Dimensions**

Formula: L1 = 25n + 106, L2 = 25n + 152 n: Stations (Maximum 16 stations)

| L \ n     | 1   | 2   | 3   | 4   | 5   | 6   | 7   | 8   | 9   | 10  | 11  | 12  | 13  | 14  | 15  | 16  |
|-----------|-----|-----|-----|-----|-----|-----|-----|-----|-----|-----|-----|-----|-----|-----|-----|-----|
| <b>L1</b> | 131 | 156 | 181 | 206 | 231 | 256 | 281 | 306 | 331 | 356 | 381 | 406 | 431 | 456 | 481 | 506 |
| <b>L2</b> | 177 | 202 | 227 | 252 | 277 | 302 | 327 | 352 | 377 | 402 | 427 | 452 | 477 | 502 | 527 | 552 |

# VQC4000 Series

## S VQC4000

Kit (Serial transmission kit): For EX260 Integrated-type (Output) Serial Transmission System

IP40 compliant

IP67 compliant

VV5QC41

S kit (Serial transmission kit: EX260)

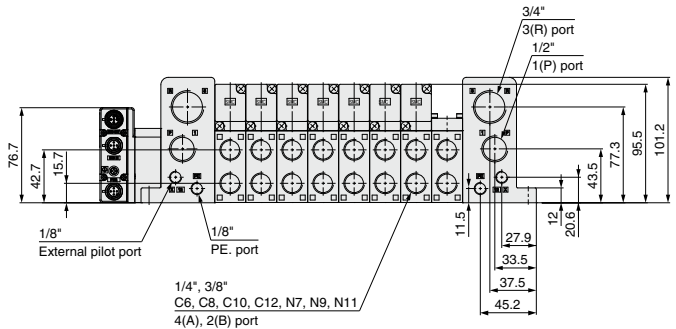
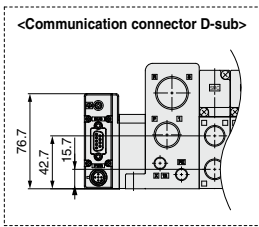
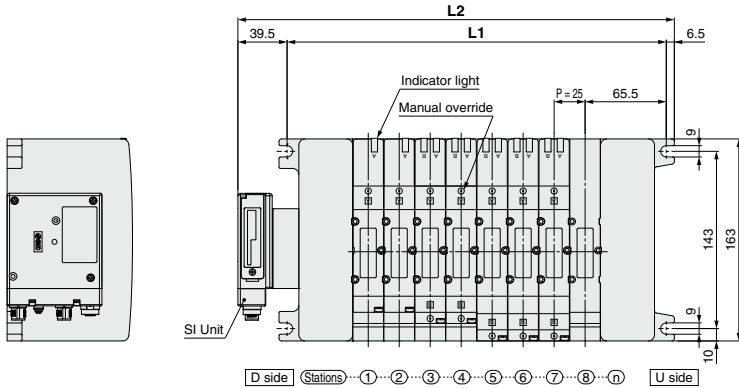

Note) The dimensions of the bottom ported type are common to all S kits.

### Dimensions

n: Stations (Maximum 16 stations)

| L \ n     | 1   | 2   | 3   | 4   | 5   | 6   | 7   | 8   | 9   | 10  | 11  | 12  | 13  | 14  | 15  | 16  |
|-----------|-----|-----|-----|-----|-----|-----|-----|-----|-----|-----|-----|-----|-----|-----|-----|-----|
| <b>L1</b> | 131 | 156 | 181 | 206 | 231 | 256 | 281 | 306 | 331 | 356 | 381 | 406 | 431 | 456 | 481 | 506 |
| <b>L2</b> | 177 | 202 | 227 | 252 | 277 | 302 | 327 | 352 | 377 | 402 | 427 | 452 | 477 | 502 | 527 | 552 |



# VQC4000 Series

## S VQC4000

Kit (Serial transmission kit): For EX126 Integrated-type (Output) Serial Transmission System **IP67 compliant**

VV5QC41

S kit (Serial transmission kit: EX126)

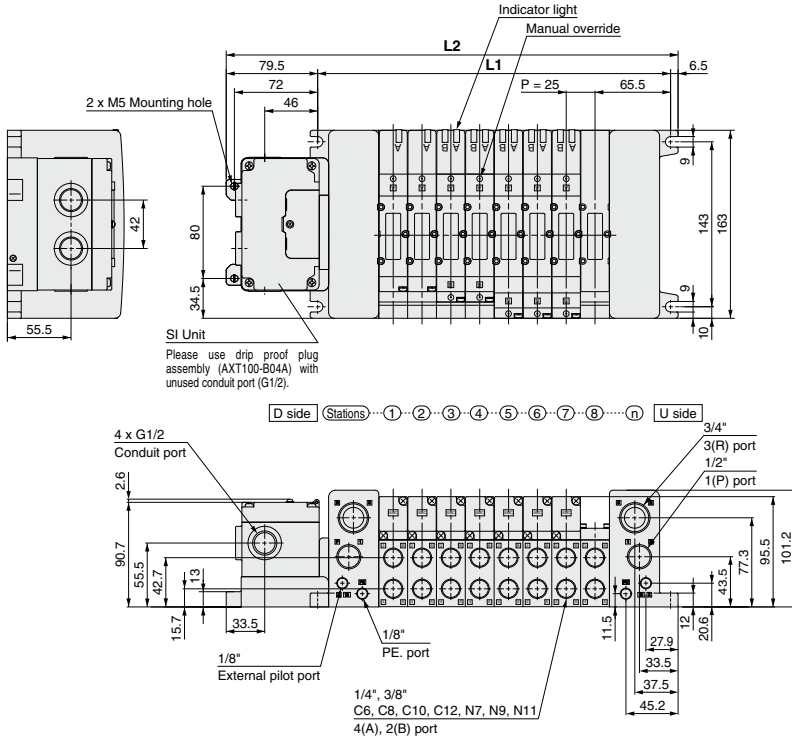

Note) The dimensions of the bottom ported type are common to all S kits.

### Dimensions

Formula:  $L1 = 25n + 106$ ,  $L2 = 25n + 192$  n: Stations (Maximum 16 stations)

| L \ n | 1   | 2   | 3   | 4   | 5   | 6   | 7   | 8   | 9   | 10  | 11  | 12  | 13  | 14  | 15  | 16  |
|-------|-----|-----|-----|-----|-----|-----|-----|-----|-----|-----|-----|-----|-----|-----|-----|-----|
| L1    | 131 | 156 | 181 | 206 | 231 | 256 | 281 | 306 | 331 | 356 | 381 | 406 | 431 | 456 | 481 | 506 |
| L2    | 217 | 242 | 267 | 292 | 317 | 342 | 367 | 392 | 417 | 442 | 467 | 492 | 517 | 542 | 567 | 592 |

# VQC4000 Series

## F VQC4000 Kit (D-sub connector kit) IP40 compliant

- Using our D-sub connector for electrical connections greatly reduces labor, while it also minimizes wiring and saves space.
- We use a D-sub connector (25P) that conforms to MIL standards and is therefore widely compatible with many standard commercial models.
- Top or side entry for the connector can be changed freely, allowing for changes even after mounting, to meet any changing needs for space.

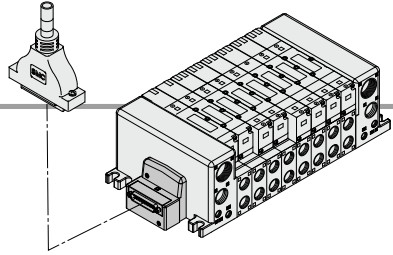

### Electrical Wiring Specifications

**D-sub connector**

As the standard electrical wiring specification used is for 12 stations or less, double wiring (connected to SOL. A and SOL. B) is used for the internal wiring of each station regardless of valve and option types. Mixed single and double wiring are available as options. Refer to special wiring specifications (options) below.

**Lead wire colors for D-sub connector assemblies (AXT100-DS25-015, 030, 050)**

| Standard wiring | Terminal no. | Lead wire color | Dot marking |       |
|-----------------|--------------|-----------------|-------------|-------|
| Station 1       | SOL.A        | 1               | Black       | None  |
|                 | SOL.B        | 14              | Yellow      | Black |
| Station 2       | SOL.A        | 2               | Brown       | None  |
|                 | SOL.B        | 15              | Pink        | Black |
| Station 3       | SOL.A        | 3               | Red         | None  |
|                 | SOL.B        | 16              | Blue        | White |
| Station 4       | SOL.A        | 4               | Orange      | None  |
|                 | SOL.B        | 17              | Purple      | None  |
| Station 5       | SOL.A        | 5               | Yellow      | None  |
|                 | SOL.B        | 18              | Gray        | None  |
| Station 6       | SOL.A        | 6               | Pink        | None  |
|                 | SOL.B        | 19              | Orange      | Black |
| Station 7       | SOL.A        | 7               | Blue        | None  |
|                 | SOL.B        | 20              | Red         | White |
| Station 8       | SOL.A        | 8               | Purple      | White |
|                 | SOL.B        | 21              | Brown       | White |
| Station 9       | SOL.A        | 9               | Gray        | Black |
|                 | SOL.B        | 22              | Pink        | Red   |
| Station 10      | SOL.A        | 10              | White       | Black |
|                 | SOL.B        | 23              | Gray        | Red   |
| Station 11      | SOL.A        | 11              | White       | Red   |
|                 | SOL.B        | 24              | Black       | White |
| Station 12      | SOL.A        | 12              | Yellow      | Red   |
|                 | SOL.B        | 25              | White       | None  |
| COM.            | 13           | Orange          | Red         |       |

### Special Wiring Specifications (Options)

(For 25P)

Mixed single and double wiring are available as options. The maximum number of manifold stations is determined by the number of solenoids. Count one point for a single solenoid type and two points for a double solenoid type. The total number of solenoids (points) must not exceed 24.

### Cable Assembly

**AXT100-DS25-030**  
015  
050

(D-sub connector cable assemblies can be ordered with manifolds.)  
(Refer to manifold ordering.)

**Lead wire colors for D-sub connector cable assembly terminal numbers**

| Terminal no. | Lead wire color | Dot marking |
|--------------|-----------------|-------------|
| 1            | Black           | None        |
| 2            | Brown           | None        |
| 3            | Red             | None        |
| 4            | Orange          | None        |
| 5            | Yellow          | None        |
| 6            | Pink            | None        |
| 7            | Blue            | None        |
| 8            | Purple          | White       |
| 9            | Gray            | Black       |
| 10           | White           | Black       |
| 11           | White           | Red         |
| 12           | Yellow          | Red         |
| 13           | Orange          | Red         |
| 14           | Yellow          | Black       |
| 15           | Pink            | Black       |
| 16           | Blue            | White       |
| 17           | Purple          | None        |
| 18           | Gray            | None        |
| 19           | Orange          | Black       |
| 20           | Red             | White       |
| 21           | Brown           | White       |
| 22           | Pink            | Red         |
| 23           | Gray            | Red         |
| 24           | Black           | White       |
| 25           | White           | None        |

**D-sub connector cable assemblies**

| Cable length [L] | Part no.        | Note                                 |
|------------------|-----------------|--------------------------------------|
| 1.5 m            | AXT100-DS25-015 | Cable 0.3 mm <sup>2</sup> x 25 cores |
| 3 m              | AXT100-DS25-030 |                                      |
| 5 m              | AXT100-DS25-050 |                                      |

- \* When using a standard commercial connector, use a type 25P female connector conforming to MIL-C-24308.
- \* Cannot be used for transfer wiring.
- \* Lengths other than the above is also available. Please contact SMC for details.

**Electrical characteristics**

| Item                  | Characteristic |
|-----------------------|----------------|
| Conductor resistance  | 65 or less     |
| Voltage limit         | 1000           |
| Insulation resistance | 5 or more      |

(Note) The minimum bending radius for D-sub connector cables is 20 mm.

**Connector Manufacturers Example**

- Fujitsu, Limited
- Japan Aviation Electronics Industry, Limited
- J.S.T. Mfg. Co., Ltd.
- HIROSE ELECTRIC CO., LTD.

# F VQC4000

Kit (D-sub connector kit) IP40 compliant

VV5QC41

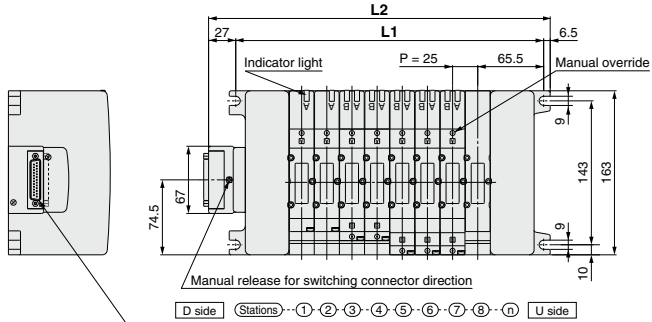

Applicable connector: D-sub connector (25P)  
(Conforms to MIL-C-24308)

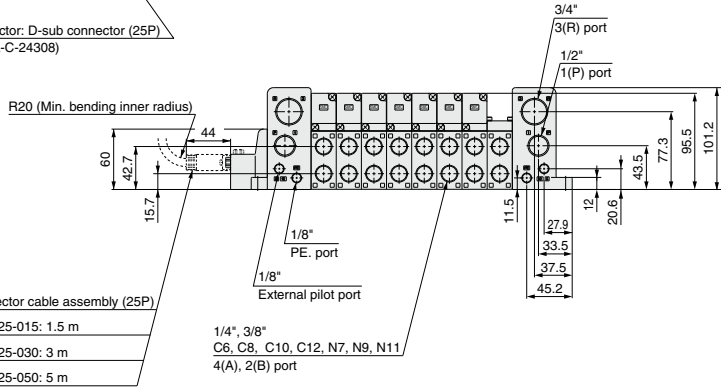

D-sub connector cable assembly (25P)

AXT100-DS25-015: 1.5 m

AXT100-DS25-030: 3 m

AXT100-DS25-050: 5 m

### Bottom ported

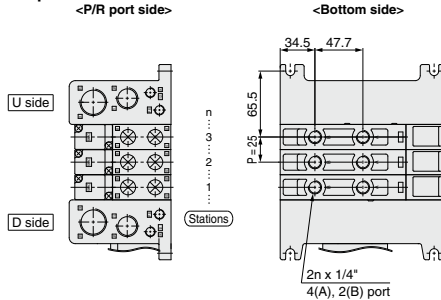

\* Other dimensions are the same as the side ported type.

### Dimensions

Formula: L1 = 25n + 106, L2 = 25n + 139.5 n: Stations (Maximum 16 stations)

| L  | n | 1     | 2     | 3     | 4     | 5     | 6     | 7     | 8     | 9     | 10    | 11    | 12    | 13    | 14    | 15    | 16    |
|----|---|-------|-------|-------|-------|-------|-------|-------|-------|-------|-------|-------|-------|-------|-------|-------|-------|
| L1 |   | 131   | 156   | 181   | 206   | 231   | 256   | 281   | 306   | 331   | 356   | 381   | 406   | 431   | 456   | 481   | 506   |
| L2 |   | 164.5 | 189.5 | 214.5 | 239.5 | 264.5 | 289.5 | 314.5 | 339.5 | 364.5 | 389.5 | 414.5 | 439.5 | 464.5 | 489.5 | 514.5 | 539.5 |

- SV
- SYJ
- SZ
- VF
- VP4
- VQ 1/2
- VQ 4/5
- VQC 1/2
- VQC 4/5
- VQZ
- SQ
- VFS
- VFR
- VQ7

# VQC4000 Series

## **P** VQC4000 Kit (Flat ribbon cable kit) IP40 compliant

- Using our flat ribbon cable for electrical connections greatly reduces labour, while it also minimizes wiring and saves space.
- We use flat ribbon cables whose connectors (26P and 20P) conform to MIL standards, and are therefore widely compatible with many standard commercial models.
- Top or side entry for the connector can be changed freely, allowing for changes even after mounting, to meet any changing needs for space.

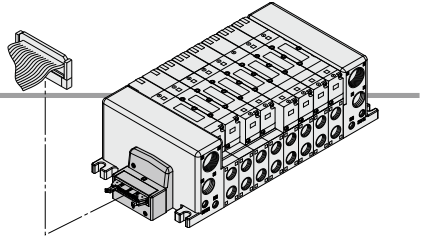

### Electrical Wiring Specifications

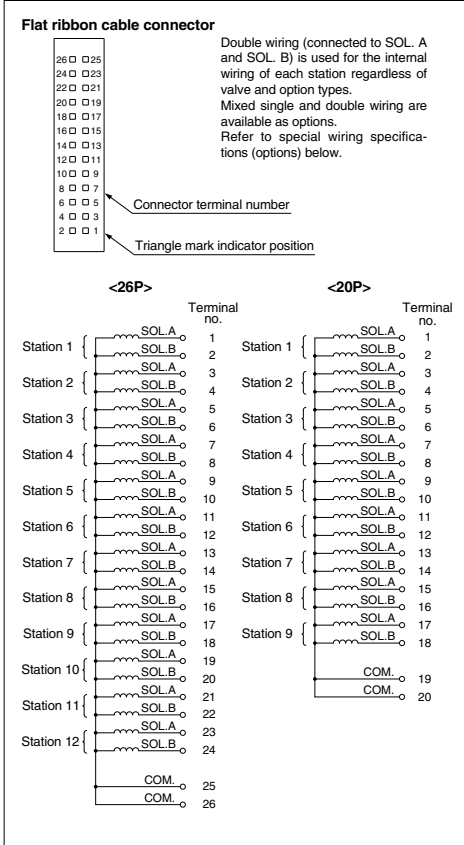

### Cable Assembly

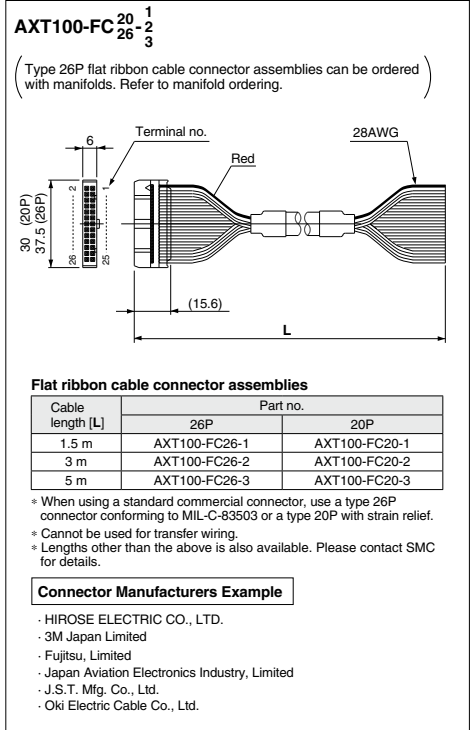

### Special Wiring Specifications (Option)

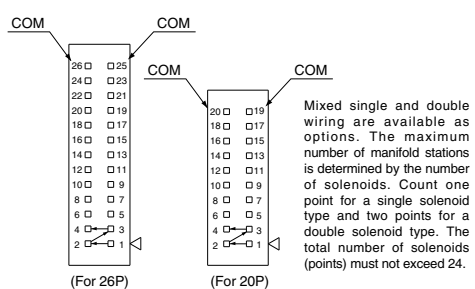

# P VQC4000

Kit (Flat ribbon cable kit) IP40 compliant

VV5QC41

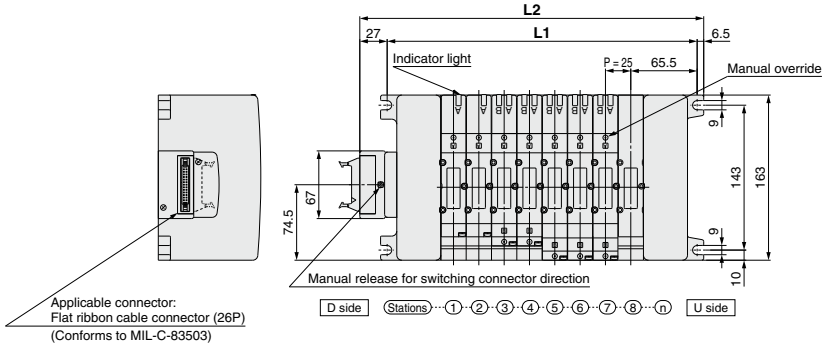

- Flat ribbon cable connector assembly (26P)
- AXT100-FC26-1: 1.5 m
- AXT100-FC26-2: 3 m
- AXT100-FC26-3: 5 m

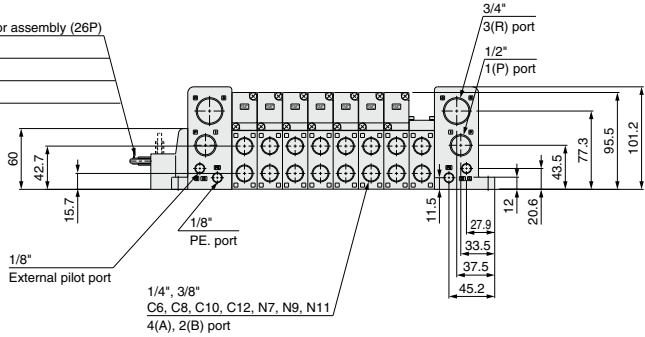

**Bottom ported**

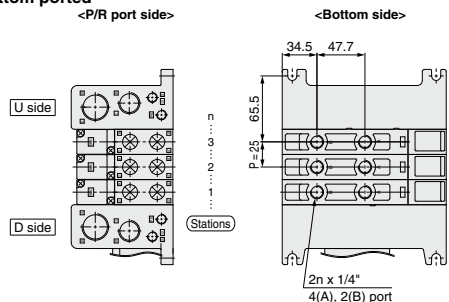

\* Other dimensions are the same as the side ported type.

**Dimensions**

Formula:  $L1 = 25n + 106$ ,  $L2 = 25n + 139.5$  n: Stations (Maximum 16 stations)

| L  | n | 1     | 2     | 3     | 4     | 5     | 6     | 7     | 8     | 9     | 10    | 11    | 12    | 13    | 14    | 15    | 16    |
|----|---|-------|-------|-------|-------|-------|-------|-------|-------|-------|-------|-------|-------|-------|-------|-------|-------|
| L1 |   | 131   | 156   | 181   | 206   | 231   | 256   | 281   | 306   | 331   | 356   | 381   | 406   | 431   | 456   | 481   | 506   |
| L2 |   | 164.5 | 189.5 | 214.5 | 239.5 | 264.5 | 289.5 | 314.5 | 339.5 | 364.5 | 389.5 | 414.5 | 439.5 | 464.5 | 489.5 | 514.5 | 539.5 |

- SV
- SYJ
- SZ
- VF
- VP4
- VQ 1/2
- VQ 4/5
- VQC 1/2
- VQC 4/5
- VQZ
- SQ
- VFS
- VFR
- VQ7

# VQC4000 Series

## T VQC4000 Kit (Terminal block box kit) IP67 compliant

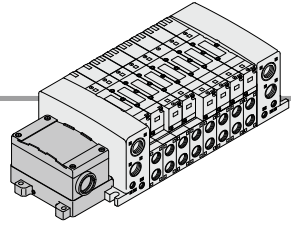

- This kit has a small terminal block inside a junction box. The provision of a G3/4 electrical entry allows connection of conduit fittings.

### Terminal Block Connection

#### Step 1. How to remove terminal block cover

Loosen the 4 mounting screws (M4) and remove the terminal block cover.

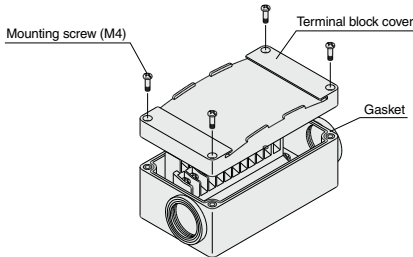

#### Step 3. How to replace the terminal block cover

Securely tighten the screws to the torque shown in the table below, after confirming that the gasket is installed correctly.

| Proper tightening torque [N·m] |
|--------------------------------|
| 0.7 to 1.2                     |

- Applicable crimped terminal: 1.25-3S, 1.25Y-3, 1.25Y-3N, 1.25Y-3.5
- Name plate: VVQ5000-N-T
- Drip proof plug assembly (for G3/4): AXT100-B06A

#### Step 2. The diagram below shows the terminal block wiring.

All stations are provided with double wiring regardless of the valves which are mounted.

Connect each wire to the power supply side, according to the markings provided inside the terminal block.

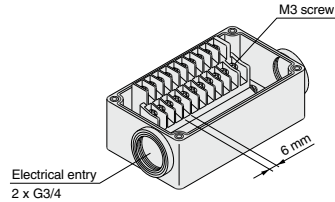

### Electrical Wiring Specifications (Conforms to IP67)

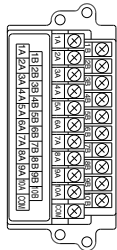

The internal wiring is double (connected to SOL. A and SOL. B) for all stations regardless of the type of valve or options. Mixed single and double wiring are available as options.

#### Standard wiring

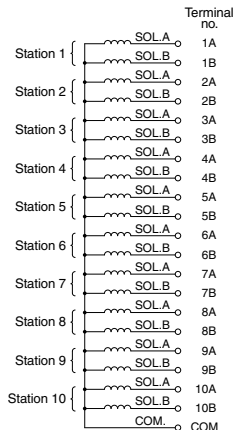

#### Special Wiring Specifications (Option)

Mixed single and double wiring are available as options. The maximum number of manifold stations is determined by the number of solenoids. Count one point for a single solenoid type and two points for a double solenoid type. The total number of solenoids (points) must not exceed 20.

##### 1. How to Order

Indicate option symbol "K" in the manifold part number and be sure to specify station positions for single or double wiring on the manifold specification sheet.

##### 2. Wiring specifications

Connector terminal numbers are connected from solenoid station 1 on the A side in the order indicated by the arrows without skipping any terminal numbers.

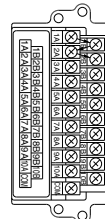

# T VQC4000

Kit (Terminal block box kit) IP67 compliant

VV5QC41

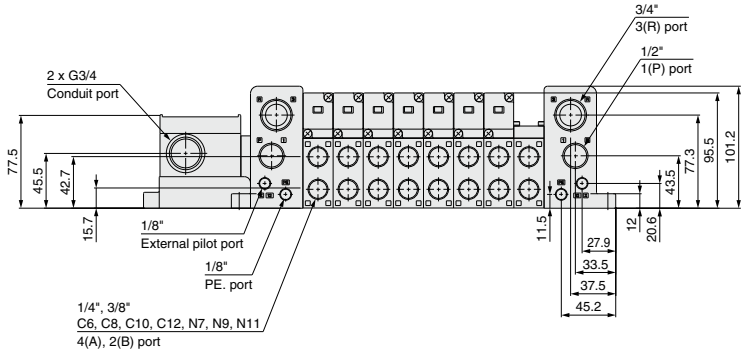
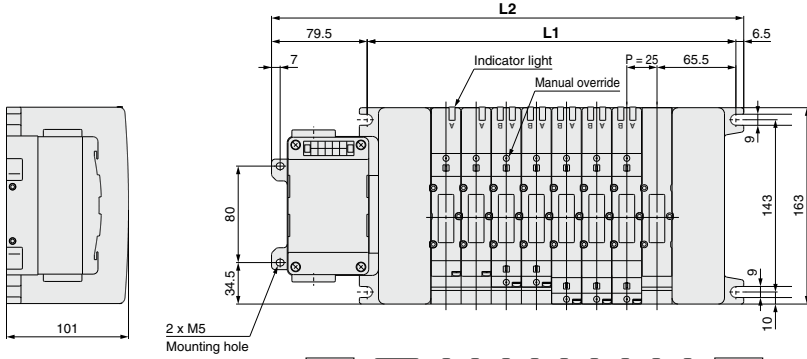

**Bottom ported**

<P/R port side>

<Bottom side>

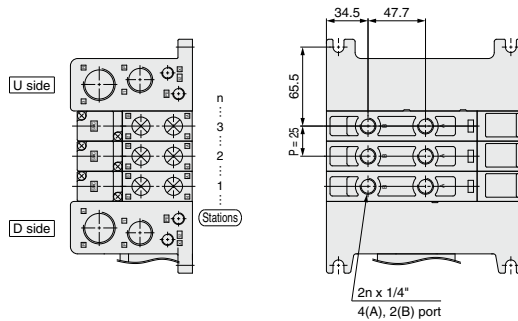

\* Other dimensions are the same as the side ported type.

**Dimensions**

Formula:  $L1 = 25n + 106$ ,  $L2 = 25n + 192$  n: Stations (Maximum 16 stations)

| L  | n | 1   | 2   | 3   | 4   | 5   | 6   | 7   | 8   | 9   | 10  | 11  | 12  | 13  | 14  | 15  | 16  |
|----|---|-----|-----|-----|-----|-----|-----|-----|-----|-----|-----|-----|-----|-----|-----|-----|-----|
| L1 |   | 131 | 156 | 181 | 206 | 231 | 256 | 281 | 306 | 331 | 356 | 381 | 406 | 431 | 456 | 481 | 506 |
| L2 |   | 217 | 242 | 267 | 292 | 317 | 342 | 367 | 392 | 417 | 442 | 467 | 492 | 517 | 542 | 567 | 592 |

- SV
- SYJ
- SZ
- VF
- VP4
- VQ 1/2
- VQ 4/5
- VQC 1/2
- VQC 4/5
- VQZ
- SQ
- VFS
- VFR
- VQ7

# VQC4000 Series

## **L** VQC4000 Kit (Lead wire kit) IP67 compliant

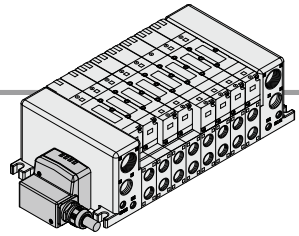

- Direct electrical entry type
- IP67 enclosure is available with use of cables with sheath and waterproof connectors.

### Electrical Wiring Specifications

#### Lead wire specifications

Lead wire

0.3 mm<sup>2</sup> x 25 cores

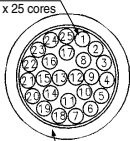

Sheath

Color: Urban white

As the standard electrical wiring specification used is for 12 stations or less, double wiring (connected to SOL. A and SOL. B) is used for the internal wiring of each station regardless of valve and option types.

Mixed single and double wiring are available as options.

Refer to special wiring specifications (options) below.

#### Lead wire length

VV5QC41-08 C12 LD **0**

Lead wire length

|   |       |
|---|-------|
| 0 | 0.6 m |
| 1 | 1.5 m |
| 2 | 3.0 m |

#### Electrical characteristics

| Item                                  | Characteristic |
|---------------------------------------|----------------|
| Conductor resistance<br>Ω/km, 20°C    | 65 or less     |
| Withstand pressure<br>V, 1 minute, AC | 1000           |
| Insulation resistance<br>MΩ/km, 20°C  | 5 or more      |

Note) Cannot be used for transfer wiring.  
The minimum bending radius for cables is 20 mm.

|            | Terminal no. | Lead wire color | Dot marking |
|------------|--------------|-----------------|-------------|
| Station 1  | SOL.A        | Black           | None        |
|            | SOL.B        | Yellow          | Black       |
| Station 2  | SOL.A        | Brown           | None        |
|            | SOL.B        | Pink            | Black       |
| Station 3  | SOL.A        | 3               | Red         |
|            | SOL.B        | 16              | Blue        |
| Station 4  | SOL.A        | 4               | Orange      |
|            | SOL.B        | 17              | Purple      |
| Station 5  | SOL.A        | 5               | Yellow      |
|            | SOL.B        | 18              | Gray        |
| Station 6  | SOL.A        | 6               | Pink        |
|            | SOL.B        | 19              | Orange      |
| Station 7  | SOL.A        | 7               | Blue        |
|            | SOL.B        | 20              | Red         |
| Station 8  | SOL.A        | 8               | Purple      |
|            | SOL.B        | 21              | Brown       |
| Station 9  | SOL.A        | 9               | Gray        |
|            | SOL.B        | 22              | Pink        |
| Station 10 | SOL.A        | 10              | White       |
|            | SOL.B        | 23              | Gray        |
| Station 11 | SOL.A        | 11              | White       |
|            | SOL.B        | 24              | Black       |
| Station 12 | SOL.A        | 12              | Yellow      |
|            | SOL.B        | 25              | White       |
|            | COM          | 13              | Orange      |

### Special Wiring Specifications (Option)

Mixed single and double wiring are available as options. The maximum number of manifold stations is determined by the number of solenoids. Count one point for a single solenoid type and two points for a double solenoid type. The total number of solenoids (points) must not exceed 24.



VQC4000

Kit (Lead wire kit) IP67 compliant

VV5QC41

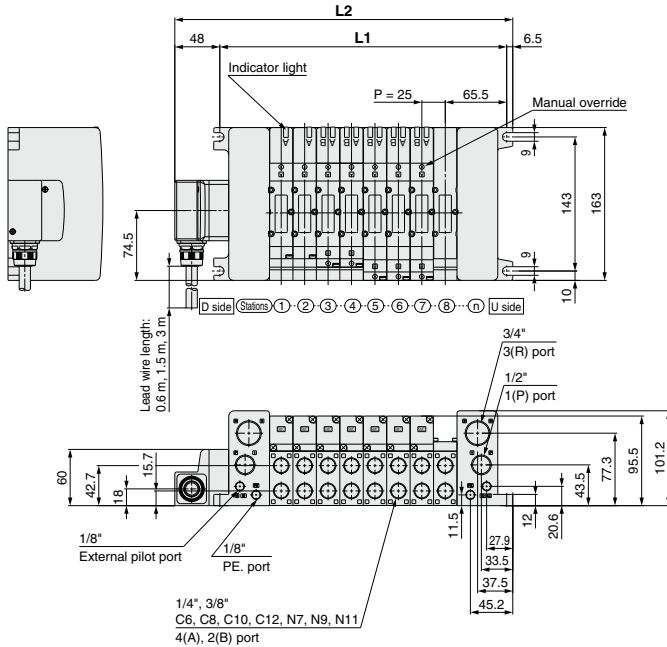

Bottom ported

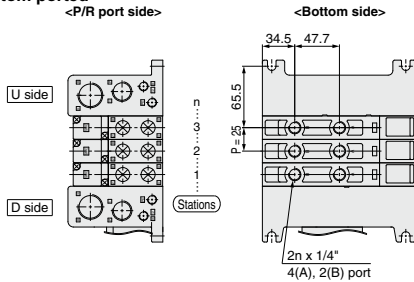

\* Other dimensions are the same as the side ported type.

Dimensions

Formula: L1 = 25n + 106, L2 = 25n + 160.5 n: Stations (Maximum 16 stations)

| L \ n | 1     | 2     | 3     | 4     | 5     | 6     | 7     | 8     | 9     | 10    | 11    | 12    | 13    | 14    | 15    | 16    |
|-------|-------|-------|-------|-------|-------|-------|-------|-------|-------|-------|-------|-------|-------|-------|-------|-------|
| L1    | 131   | 156   | 181   | 206   | 231   | 256   | 281   | 306   | 331   | 356   | 381   | 406   | 431   | 456   | 481   | 506   |
| L2    | 185.5 | 210.5 | 235.5 | 260.5 | 285.5 | 310.5 | 335.5 | 360.5 | 385.5 | 410.5 | 435.5 | 460.5 | 485.5 | 510.5 | 535.5 | 560.5 |

|         |
|---------|
| SV      |
| SYJ     |
| SZ      |
| VF      |
| VP4     |
| VQ 1/2  |
| VQ 4/5  |
| VQC 1/2 |
| VQC 4/5 |
| VQZ     |
| SQ      |
| VFS     |
| VFR     |
| VQ7     |

# VQC4000 Series

## M VQC4000 Kit (Circular connector kit) IP67 compliant

- Use of circular connectors helps streamline wiring procedure to save labor.
- IP67 enclosure is available with use of waterproof multiple connectors.

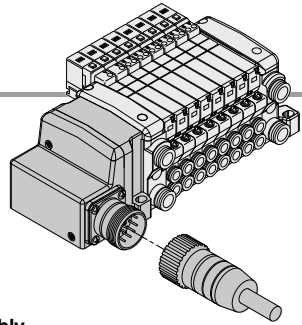

### Electrical Wiring Specifications

#### Multiple connector

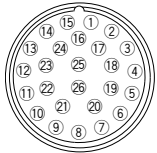

Double wiring (connected to SOL.A and SOL.B) is used for the internal wiring of each station regardless of valve and option types. Mixed single and double wiring are available as options. Refer to special wiring specifications (options) below.

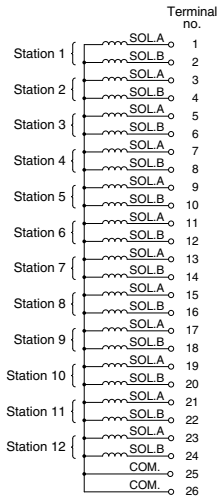

### Special Wiring Specifications (Option)

Mixed single and double wiring are available as an option. The maximum number of manifold stations is determined by the number of solenoids. Count one point for a single solenoid type and two points for a double solenoid type. The total number of solenoids (points) must not exceed 24.

### Cable Assembly

**AXT100-MC26-030**  
015  
050

(Type 26P circular connector cable assemblies can be ordered with manifolds. Refer to manifolds ordering.)

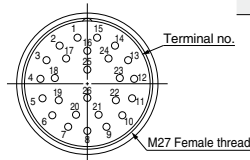
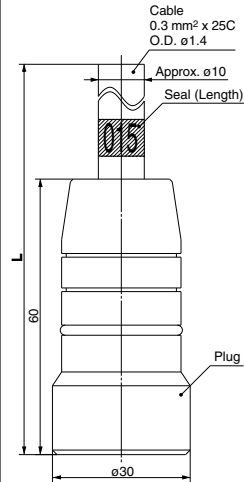

#### Lead wire colors for circular connector cable assembly terminal numbers

| Terminal no. | Lead wire color | Dot marking |
|--------------|-----------------|-------------|
| 1            | Black           | None        |
| 2            | Brown           | None        |
| 3            | Red             | None        |
| 4            | Orange          | None        |
| 5            | Yellow          | None        |
| 6            | Pink            | None        |
| 7            | Blue            | None        |
| 8            | Purple          | White       |
| 9            | Gray            | Black       |
| 10           | White           | Black       |
| 11           | White           | Red         |
| 12           | Yellow          | Red         |
| 13           | Orange          | Red         |
| 14           | Yellow          | Black       |
| 15           | Pink            | Black       |
| 16           | Blue            | White       |
| 17           | Purple          | None        |
| 18           | Gray            | None        |
| 19           | Orange          | Black       |
| 20           | Red             | White       |
| 21           | Brown           | White       |
| 22           | Pink            | Red         |
| 23           | Gray            | Red         |
| 24           | Black           | White       |
| 25           | White           | None        |
| 26           | White           | None        |

#### Electric characteristics

| Item   | Property   |
|--|------------|
| Conductor resistance<br>Ω/km, 20°C             | 65 or less |
| Voltage limit<br>V <sub>i</sub> , 1 minute, AC | 1000       |
| Insulation resistance<br>MΩ/km, 20°C           | 5 or more  |

(Note) The minimum bending radius of the multiple connector cable is 20 mm.

#### Circular connector cable assemblies

| Cable length [L] | Assembly part no. |
|------------------|-------------------|
|                  | 26P               |
| 1.5 m            | AXT100-MC26-015   |
| 3 m              | AXT100-MC26-030   |
| 5 m              | AXT100-MC26-050   |

- \* Cannot be used for transfer wiring.
- \* Lengths other than the above is also available. Please contact SMC for details.



VQC4000

Kit (Circular connector kit) IP67 compliant

VV5QC41

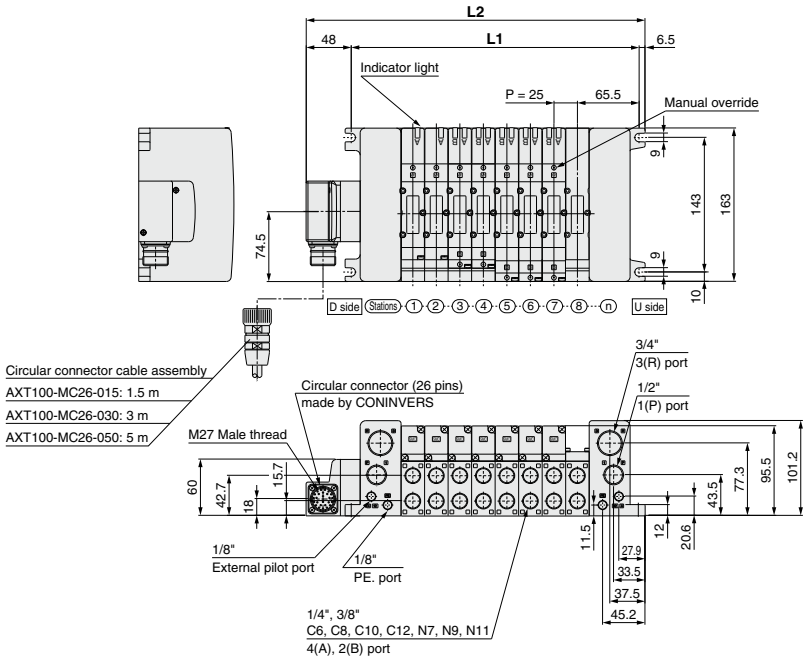

Bottom ported

<P/R port side>

<Bottom side>

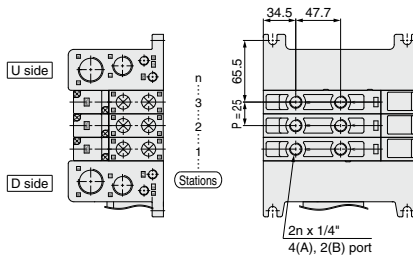

\* Other dimensions are the same as the side ported type.

Dimensions

Formula: L1 = 25n + 106, L2 = 25n + 150.5 n: Stations (Maximum 16 stations)

| n  | 1     | 2     | 3     | 4     | 5     | 6     | 7     | 8     | 9     | 10    | 11    | 12    | 13    | 14    | 15    | 16    |
|----|-------|-------|-------|-------|-------|-------|-------|-------|-------|-------|-------|-------|-------|-------|-------|-------|
| L1 | 131   | 156   | 181   | 206   | 231   | 256   | 281   | 306   | 331   | 356   | 381   | 406   | 431   | 456   | 481   | 506   |
| L2 | 185.5 | 210.5 | 235.5 | 260.5 | 285.5 | 310.5 | 335.5 | 360.5 | 385.5 | 410.5 | 435.5 | 460.5 | 485.5 | 510.5 | 535.5 | 560.5 |

|         |
|---------|
| SV      |
| SYJ     |
| SZ      |
| VF      |
| VP4     |
| VQ 1/2  |
| VQ 4/5  |
| VQC 1/2 |
| VQC 4/5 |
| VQZ     |
| SQ      |
| VFS     |
| VFR     |
| VQ7     |

# VQC4000 Series Construction

## Plug-in Unit

### Metal seal type

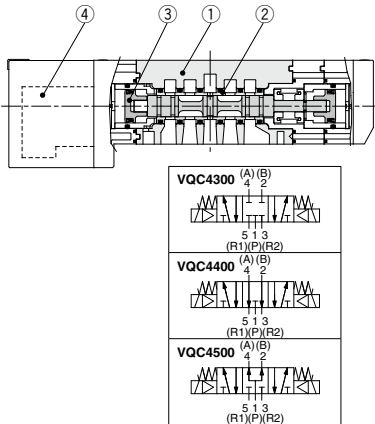
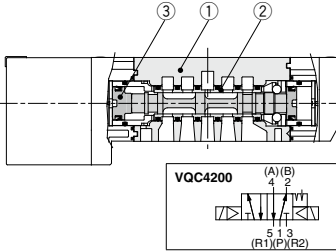
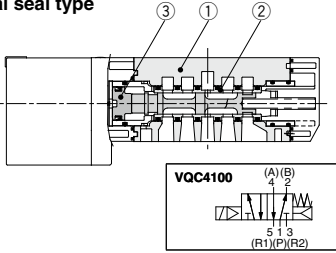

### Component Parts

| No. | Description  | Material            | Note |
|-----|--------------|---------------------|------|
| 1   | Body         | Aluminum die-casted |      |
| 2   | Spool/Sleeve | Stainless steel     |      |
| 3   | Piston       | Resin               |      |

### Replacement Parts

|   |                      |   |  |
|---|----------------------|---|--|
| 4 | Pilot valve assembly | V118 □ □ □ □ □<br>A<br>B<br>E   | <input type="checkbox"/> Coil rated voltage<br>Example) 24 VDC: 5<br>A: With light (For A side)<br>B: With light (For B side)<br>E: Without light<br>(A/B side common) |
|   |                      | <b>Coil type</b><br><input type="checkbox"/> Nil Standard (0.95 W)<br><input type="checkbox"/> Y Low wattage type (0.4 W) |  |

### Rubber seal type

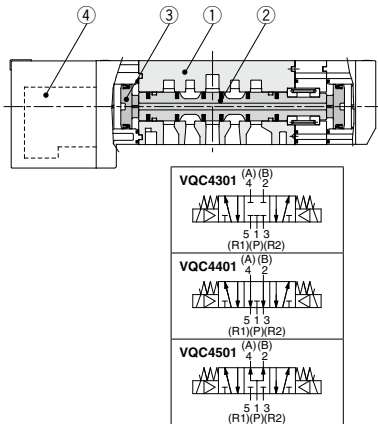
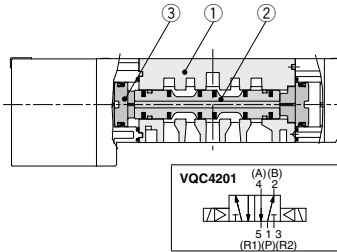
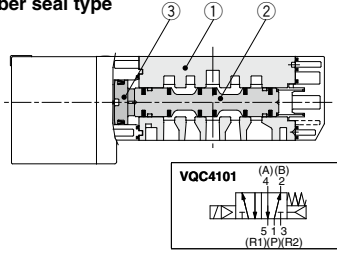

### Component Parts

| No. | Description | Material            | Note |
|-----|-------------|---------------------|------|
| 1   | Body        | Aluminum die-casted |      |
| 2   | Spool valve | Aluminum, HNBR      |      |
| 3   | Piston      | Resin               |      |

### Replacement Parts

|   |                      |   |  |
|---|----------------------|---|--|
| 4 | Pilot valve assembly | V118 □ □ □ □ □<br>A<br>B<br>E   | <input type="checkbox"/> Coil rated voltage<br>Example) 24 VDC: 5<br>A: With light (For A side)<br>B: With light (For B side)<br>E: Without light<br>(A/B side common) |
|   |                      | <b>Coil type</b><br><input type="checkbox"/> Nil Standard (0.95 W)<br><input type="checkbox"/> Y Low wattage type (0.4 W) |  |

# VQC4000 Series

## Exploded View of Manifold

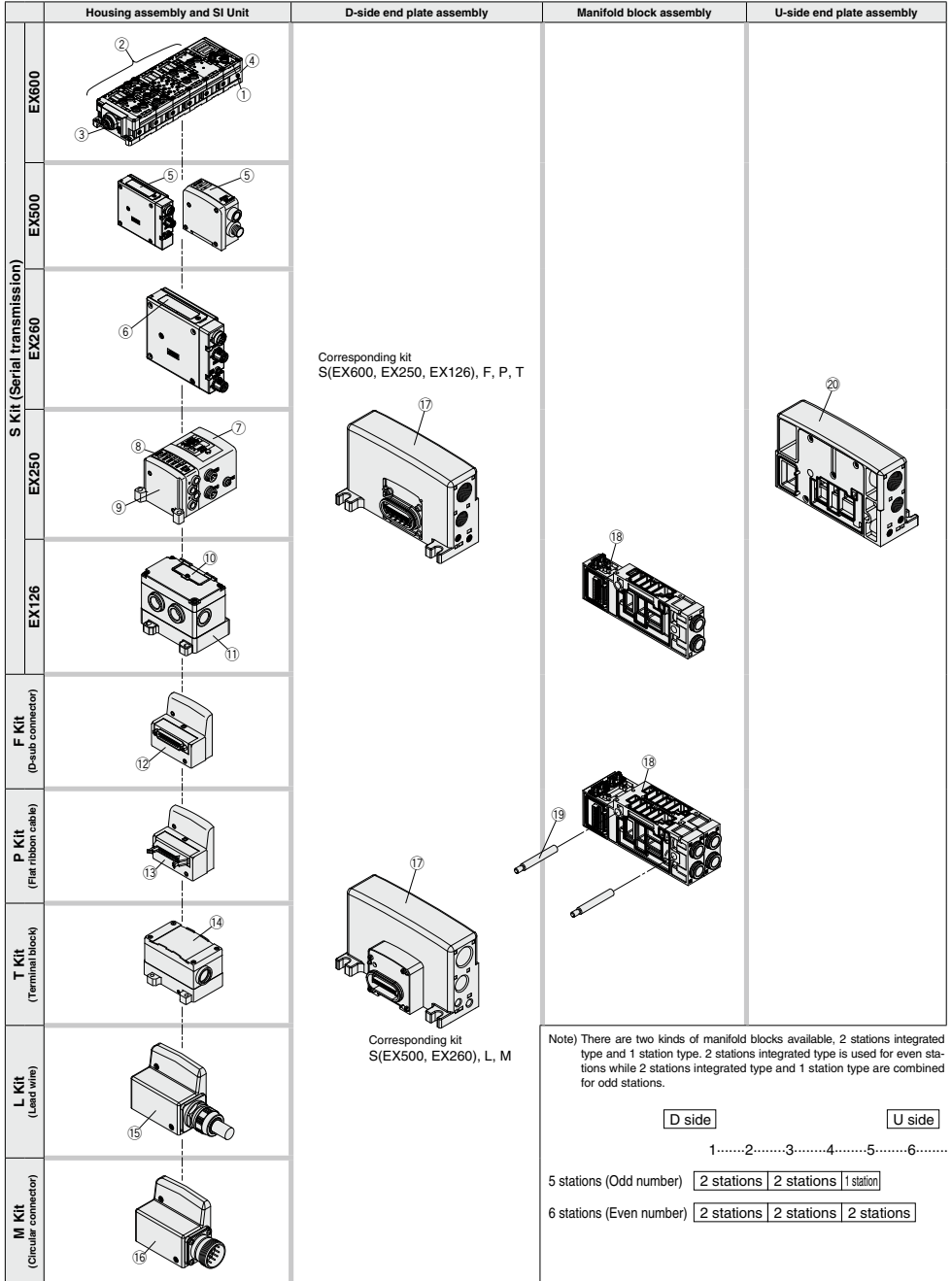

- SV
- SYJ
- SZ
- VF
- VP4
- VQ 1/2
- VQ 4/5
- VQC 1/2
- VQC 4/5
- VQZ
- SQ
- VFS
- VFR
- VQ7

# VQC4000 Series

## Manifold Assembly Part No.

### Housing Assembly and SI Unit/Input Block

| No.       | Description               | Part no.                    | Note   |   |
|-----------|---------------------------|-----------------------------|--|---|
| ①         | SI Unit                   | EX600-SDN1A                 | DeviceNet™, Negative common (PNP)  |   |
|           |                           | EX600-SDN2A                 | DeviceNet™, Positive common (NPN)  |   |
|           |                           | EX600-SMJ1                  | CC-Link, Negative common (PNP)   |   |
|           |                           | EX600-SMJ2                  | CC-Link, Positive common (NPN)   |   |
|           |                           | EX600-SPR1A                 | PROFIBUS DP, Negative common (PNP)   |   |
|           |                           | EX600-SPR2A                 | PROFIBUS DP, Positive common (NPN)   |   |
|           |                           | EX600-SEN1                  | EtherNet/IP™ (1 port), Negative common (PNP)   |   |
|           |                           | EX600-SEN2                  | EtherNet/IP™ (1 port), Positive common (NPN)   |   |
|           |                           | EX600-SEN3                  | EtherNet/IP™ (2 port), Negative common (PNP)   |   |
|           |                           | EX600-SEN4                  | EtherNet/IP™ (2 port), Positive common (NPN)   |   |
|           |                           | EX600-SPN1                  | PROFINET, Negative common (PNP)  |   |
|           |                           | EX600-SPN2                  | PROFINET, Positive common (NPN)  |   |
|           |                           | EX600-SEC1                  | EtherCAT, Negative common (PNP)  |   |
|           |                           | EX600-SEC2                  | EtherCAT, Positive common (NPN)  |   |
|           |                           | EX600-WEN1 <sup>Note)</sup> | Wireless base module EtherNet/IP™ Negative common (PNP)                              |   |
|           |                           | EX600-WEN2 <sup>Note)</sup> | Wireless base module EtherNet/IP™ Positive common (NPN)                              |   |
|           |                           | EX600-WPN1 <sup>Note)</sup> | Wireless base module PROFINET Negative common (PNP)                                  |   |
|           |                           | EX600-WPN2 <sup>Note)</sup> | Wireless base module PROFINET Positive common (NPN)                                  |   |
|           |                           | EX600-WSV1 <sup>Note)</sup> | Wireless remote module Negative common (PNP)   |   |
|           |                           | EX600-WSV2 <sup>Note)</sup> | Wireless remote module Positive common (NPN)   |   |
| ②         | Digital Input Unit        | EX600-DXNB                  | NPN input, M12 connector, 5 pins (4 pcs.), 8 inputs                                  |   |
|           |                           | EX600-DXPB                  | PNP input, M12 connector, 5 pins (4 pcs.), 8 inputs                                  |   |
|           |                           | EX600-DXNC                  | NPN input, M8 connector, 3 pins (8 pcs.), 8 inputs                                   |   |
|           |                           | EX600-DXNC1                 | NPN input, M8 connector, 3 pins (8 pcs.), 8 inputs, with open circuit detection      |   |
|           |                           | EX600-DXPC                  | PNP input, M8 connector, 3 pins (8 pcs.), 8 inputs                                   |   |
|           |                           | EX600-DXPC1                 | PNP input, M8 connector, 3 pins (8 pcs.), 8 inputs, with open circuit detection      |   |
|           |                           | EX600-DXND                  | NPN input, M12 connector, 5 pins (8 pcs.), 16 inputs                                 |   |
|           |                           | EX600-DXPD                  | PNP input, M12 connector, 5 pins (8 pcs.), 16 inputs                                 |   |
|           |                           | EX600-DXNE                  | NPN input, D-sub connector, 25 pins, 16 inputs                                       |   |
|           |                           | EX600-DXPE                  | PNP input, D-sub connector, 25 pins, 16 inputs                                       |   |
|           |                           | EX600-DXNF                  | NPN input, Spring type terminal box, 32 pins, 16 inputs                              |   |
|           |                           | EX600-DXPF                  | PNP input, Spring type terminal box, 32 pins, 16 inputs                              |   |
|           |                           | Digital Output Unit         | EX600-DYNB   | NPN output, M12 connector, 5 pins (4 pcs.), 8 outputs     |
|           |                           |                             | EX600-DYPB   | PNP output, M12 connector, 5 pins (4 pcs.), 8 outputs     |
|           |                           |                             | EX600-DYNE   | NPN output, D-sub connector, 25 pins, 16 outputs          |
|           |                           |                             | EX600-DYPE   | PNP output, D-sub connector, 25 pins, 16 outputs          |
|           |                           |                             | EX600-DYNF   | NPN output, Spring type terminal box, 32 pins, 16 outputs |
|           | EX600-DYPF                |                             | PNP output, Spring type terminal box, 32 pins, 16 outputs                            |   |
|           | Digital Input/Output Unit | EX600-DMNE                  | NPN input/output, D-sub connector, 25 pins, 8 inputs/outputs                         |   |
|           |                           | EX600-DMPE                  | PNP input/output, D-sub connector, 25 pins, 8 inputs/outputs                         |   |
|           |                           | EX600-DMNF                  | NPN input/output, Spring type terminal box, 32 pins, 8 inputs/outputs                |   |
|           |                           | EX600-DMPF                  | PNP input/output, Spring type terminal box, 32 pins, 8 inputs/outputs                |   |
|           | Analog Input Unit         |                             | EX600-AXA  | M12 connector, 5 pins (2 pcs.), 2-channel input           |
|           | Analog Output Unit        |                             | EX600-AYA  | M12 connector, 5 pins (2 pcs.), 2-channel output          |
|           | Analog Input/Output Unit  |                             | EX600-AMB  | M12 connector, 5 pins (4 pcs.), 2-channel input/output    |
|           | ③                         | End plate                   | EX600-ED2  | M12 power supply connector, B-coded                       |
|           |                           |                             | EX600-ED3  | 7/8 inch power supply connector                           |
| EX600-ED4 |                           |                             | M12 power supply connector IN/OUT, A-coded, Pin arrangement 1                        |   |
| EX600-ED5 |                           |                             | M12 power supply connector IN/OUT, A-coded, Pin arrangement 2                        |   |
| ④         | Valve plate               | EX600-ZMV1                  | Enclosed parts: Round head screws (M4 x 6) 2 pcs., Round head screws (M3 x 8) 4 pcs. |   |
| ⑤         | SI Unit                   | EX500-S103                  | EtherNet/IP™, PROFINET, Negative common (PNP)  |   |
|           |                           | EX500-Q001                  | DeviceNet™, PROFIBUS DP, EtherNet/IP™, Positive common (NPN)                         |   |
|           |                           | EX500-Q101                  | DeviceNet™, PROFIBUS DP, EtherNet/IP™, Negative common (PNP)                         |   |

Note) The wireless system is suitable for use only in a country where it is in accordance with the Radio Act and regulations of that country.

**Manifold Assembly Part No.**

**Housing Assembly and SI Unit/Input Block**

| No.        | Description   | Part no.         | Note  |
|------------|---|------------------|---|
| 6          | SI Unit   | EX260-SDN1       | DeviceNet™, M12 connector, 32 outputs, Negative common (PNP)                            |
|            |   | EX260-SDN2       | DeviceNet™, M12 connector, 32 outputs, Positive common (NPN)                            |
|            |   | EX260-SDN3       | DeviceNet™, M12 connector, 16 outputs, Negative common (PNP)                            |
|            |   | EX260-SDN4       | DeviceNet™, M12 connector, 16 outputs, Positive common (NPN)                            |
|            |   | EX260-SRP1       | PROFIBUS DP, M12 connector, 32 outputs, Negative common (PNP)                           |
|            |   | EX260-SRP2       | PROFIBUS DP, M12 connector, 32 outputs, Positive common (NPN)                           |
|            |   | EX260-SRP3       | PROFIBUS DP, M12 connector, 16 outputs, Negative common (PNP)                           |
|            |   | EX260-SRP4       | PROFIBUS DP, M12 connector, 16 outputs, Positive common (NPN)                           |
|            |   | EX260-SRP5       | PROFIBUS DP, D-sub connector, 32 outputs, Negative common (PNP)                         |
|            |   | EX260-SRP6       | PROFIBUS DP, D-sub connector, 32 outputs, Positive common (NPN)                         |
|            |   | EX260-SRP7       | PROFIBUS DP, D-sub connector, 16 outputs, Negative common (PNP)                         |
|            |   | EX260-SRP8       | PROFIBUS DP, D-sub connector, 16 outputs, Positive common (NPN)                         |
|            |   | EX260-SMJ1       | CC-Link, M12 connector, 32 outputs, Negative common (PNP)                               |
|            |   | EX260-SMJ2       | CC-Link, M12 connector, 32 outputs, Positive common (NPN)                               |
|            |   | EX260-SMJ3       | CC-Link, M12 connector, 16 outputs, Negative common (PNP)                               |
|            |   | EX260-SMJ4       | CC-Link, M12 connector, 16 outputs, Positive common (NPN)                               |
|            |   | EX260-SEC1       | EtherCAT, M12 connector, 32 outputs, Negative common (PNP)                              |
|            |   | EX260-SEC2       | EtherCAT, M12 connector, 32 outputs, Positive common (NPN)                              |
|            |   | EX260-SEC3       | EtherCAT, M12 connector, 16 outputs, Negative common (PNP)                              |
|            |   | EX260-SEC4       | EtherCAT, M12 connector, 16 outputs, Positive common (NPN)                              |
|            |   | EX260-SPN1       | PROFINET, M12 connector, 32 outputs, Negative common (PNP)                              |
|            |   | EX260-SPN2       | PROFINET, M12 connector, 32 outputs, Positive common (NPN)                              |
|            |   | EX260-SPN3       | PROFINET, M12 connector, 16 outputs, Negative common (PNP)                              |
|            |   | EX260-SPN4       | PROFINET, M12 connector, 16 outputs, Positive common (NPN)                              |
|            |   | EX260-SEN1       | EtherNet/IP™, M12 connector, 32 outputs, Negative common (PNP)                          |
|            |   | EX260-SEN2       | EtherNet/IP™, M12 connector, 32 outputs, Positive common (NPN)                          |
|            |   | EX260-SEN3       | EtherNet/IP™, M12 connector, 16 outputs, Negative common (PNP)                          |
|            |   | EX260-SEN4       | EtherNet/IP™, M12 connector, 16 outputs, Positive common (NPN)                          |
|            |   | EX260-SPL1       | Ethernet POWERLINK, M12 connector, 32 outputs, Negative common (PNP)                    |
|            |   | EX260-SPL3       | Ethernet POWERLINK, M12 connector, 16 outputs, Negative common (PNP)                    |
| EX260-SIL1 | IO-Link, M12 connector, 32 outputs, Negative common (PNP) |                  |   |
| 7          | SI Unit   | EX250-SPR1       | PROFIBUS DP, Negative common (PNP)  |
|            |   | EX250-SAS3       | AS-Interface, 8 in/8 out, 31 slave modes, 2 power supply systems, Negative common (PNP) |
|            |   | EX250-SAS5       | AS-Interface, 4 in/4 out, 31 slave modes, 2 power supply systems, Negative common (PNP) |
|            |   | EX250-SAS7       | AS-Interface, 8 in/8 out, 31 slave modes, 1 power supply system, Negative common (PNP)  |
|            |   | EX250-SAS9       | AS-Interface, 4 in/4 out, 31 slave modes, 1 power supply system, Negative common (PNP)  |
|            |   | EX250-SCA1A      | CANopen, Negative common (PNP)  |
|            |   | EX250-SDN1       | DeviceNet™, Negative common (PNP)   |
|            |   | EX250-SEN1       | EtherNet/IP™, Negative common (PNP)   |
| 8          | Input block   | EX250-IE1        | M12, 2 inputs   |
|            |   | EX250-IE2        | M12, 4 inputs   |
|            |   | EX250-IE3        | M8, 4 inputs  |
| 9          | End plate assembly  | EX250-EA1        | Direct mounting   |
|            |   | EX250-EA2        | DIN rail mounting   |
| 10         | SI Unit   | EX126D-SMJ1      | CC-Link, Positive common (NPN)  |
| 11         | Terminal block plate                                      | VVQC1000-74A-2   | For EX126 SI Unit mounting  |
| 12         | D-sub connector housing assembly                          | VVQC1000-F25-1   | F kit, 25 pins  |
| 13         | Flat ribbon cable housing assembly                        | VVQC1000-P26-1   | P kit, 26 pins  |
|            |   | VVQC1000-P20-1   | P kit, 20 pins  |
| 14         | Terminal block box housing assembly                       | VVQC1000-T0-1    | T kit   |
| 15         | Lead wire housing assembly                                | VVQC1000-L25-0-1 | L kit with 0.6 m lead wire  |
|            |   | VVQC1000-L25-1-1 | L kit with 1.5 m lead wire  |
|            |   | VVQC1000-L25-2-1 | L kit with 3.0 m lead wire  |
| 16         | Circular connector housing assembly                       | VVQC1000-M26-1   | M kit, 26 pins  |

SV

SYJ

SZ

VF

VP4

VQ

1/2

VQ

4/5

VQC

1/2

VQC

4/5

VQZ

SQ

VFS

VFR

VQ7

# VQC4000 Series

## Manifold Assembly Part No.

### D-side end plate assembly

#### ⑰ D-side end plate assembly part no.

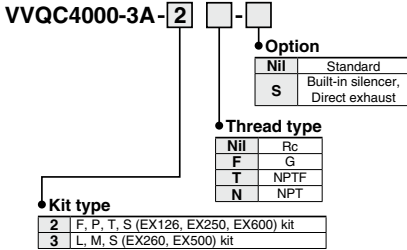

### U-side end plate assembly

#### ⑳ U-side end plate assembly part no.

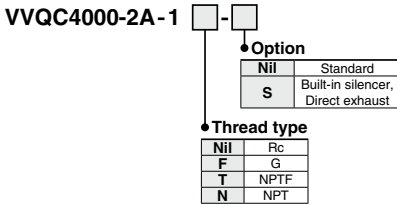

### Manifold block assembly

#### ⑱ Manifold block assembly part no.

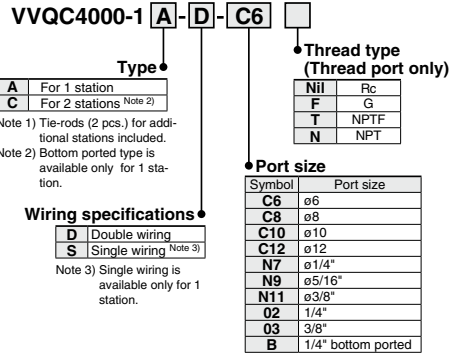



#### ⑲ Tie-rod assembly part no. (2 units)

|         |               |
|---------|---------------|
| VQC4000 | VVQC4000-TR-□ |
|---------|---------------|

Note 1) Please order when reducing the number of manifold stations. When increasing the number of stations, additional orders are not required since they are included in the manifold block assembly.  
Note 2) Number of stations, 02 to 16

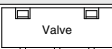
## List of Valves, Options, and Mounting Bolts

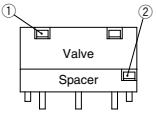
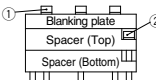
| Number of options   | Valve and options  | Bolt part no.   | Qty (pcs)   | Note   | Option mounting diagram  |
|---|--|---|---|--|--|
| 0   | Single valve   | AXT632-17-4 (M3 x 37)   | 3   |  |    |
|   | Blanking plate (VVQ4000-10A- $\frac{1}{2}$ )   | AXT632-38-1 (M3 x 14)   | 4   | For manifold   |    |
| 1   | Valve + Individual SUP spacer (VVQ4000-P- $\frac{1}{2}$ - $\frac{3}{8}$ )  | ① AXT632-17-10 (M3 x 62)<br>② AXT632-17-19 (M3 x 26)                  | 3<br>2  | For manifold   |    |
|   | Valve + Individual EXH spacer (VVQ4000-R- $\frac{1}{2}$ - $\frac{3}{8}$ )  | ① AXT632-17-10 (M3 x 62)<br>② AXT632-17-19 (M3 x 26)                  | 3<br>2  | For manifold   |  |
|   | Valve + Restrictor spacer (VVQ4000-20A- $\frac{1}{2}$ )  | ① AXT632-17-10 (M3 x 62)<br>② AXT632-17-19 (M3 x 26)                  | 3<br>2  | Not necessary when mounting the sub-plate.                                   |  |
|   | Valve + Release valve spacer (VVQ4000-24A- $\frac{1}{2}$ D)  | ① AXT632-17-10 (M3 x 62)<br>② AXT632-17-19 (M3 x 26)                  | 3<br>2  | For manifold   |  |
|   | Valve + SUP stop valve spacer (VVQ4000-37A- $\frac{1}{2}$ )  | ① AXT632-17-10 (M3 x 62)<br>② AXT632-17-19 (M3 x 26)                  | 3<br>2  | Not necessary when mounting the sub-plate.                                   |  |
|   | Valve + Double check spacer with residual pressure exhaust (VVQ4000-25A- $\frac{1}{2}$ )   | ① AXT632-17-11 (M3 x 87)<br>② AXT632-41-1 (M3 x 54)                   | 3<br>2  | Not necessary when mounting the sub-plate.                                   |  |
|   | Valve + Interface regulator (ARBQ4000-00 $\hat{A}$ - $\frac{1}{2}$ )   | ① AXT632-17-11 (M3 x 87)<br>② AXT632-17-8 (M3 x 52)                   | 3<br>2  | Not necessary when mounting the sub-plate.                                   |  |
|   | Blanking plate + SUP stop valve (Top) (Bottom)   | ① AXT632-41-4 (M3 x 42)<br>② AXT632-17-19 (M3 x 26)                   | 3<br>2  | For manifold   |  |
|   |  |   |   |  |  |
|   | 2  | Valve + Individual SUP + Individual EXH (Top) (Bottom) (Bottom) (Top) | ① AXT632-17-11 (M3 x 87)<br>② AXT632-17-8 (M3 x 52) | 3<br>2   |  |
| Valve + Restrictor + Individual SUP or Individual EXH (Top) (Bottom) (Top) (Bottom)   |  | ① AXT632-17-11 (M3 x 87)<br>② AXT632-17-8 (M3 x 52)                   | 3<br>2  | For manifold<br>The individual EXH cannot be mounted on the top.             |  |
| Valve + SUP stop valve + Individual SUP, Individual EXH or Restrictor (Top) (Bottom)  |  | ① AXT632-17-11 (M3 x 87)<br>② AXT632-17-8 (M3 x 52)                   | 3<br>2  | For manifold   |  |
| Valve + Double check spacer with residual pressure exhaust (Top) (Bottom) + Individual SUP or Individual EXH (Bottom)           |  | ① AXT632-17-14 (M3 x 112)<br>② AXT632-41-2 (M3 x 78)                  | 3<br>2  | For manifold   |  |
|   |  |   |   |  |  |
| Valve + Interface regulator + Individual SUP, Individual EXH or Restrictor (Top) (Bottom)                                       |  | ① AXT632-17-14 (M3 x 112)<br>② AXT632-41-2 (M3 x 78)                  | 3<br>2  | For manifold<br>The individual EXH and restrictor can be mounted on the top. |  |
|   |  |   |   |  |  |
| Valve + Restrictor + Double check spacer with residual pressure exhaust (Top) (Bottom)  |  | ① AXT632-17-14 (M3 x 112)<br>② AXT632-41-2 (M3 x 78)                  | 3<br>2  | For manifold   |  |
|   |  |   |   |  |  |
| Valve + Double check spacer with residual pressure exhaust (Bottom) + Interface regulator (Top)                                 |  | ① AXT632-17-16 (M3 x 137)<br>② AXT632-41-3 (M3 x 103)                 | 3<br>2  | For manifold   |  |
|   |  |   |   |  |  |
| Blanking plate + SUP stop valve + Individual SUP (Top) (Bottom)   | ① AXT632-17-17 (M3 x 66)<br>② AXT632-17-8 (M3 x 52)  | 3<br>2  | For manifold  |  |  |
|   |  |   |   |  |  |
| 3   | Valve + SUP stop valve (Top) + Individual SUP (Middle, Bottom) + Individual EXH (Middle, Bottom)   | ① AXT632-17-14 (M3 x 112)<br>② AXT632-17-13 (M3 x 77)                 | 3<br>2  | For manifold   |  |
|   |  |   |   |  |  |
|   | Valve + Double check spacer with residual pressure exhaust (Top) + Individual SUP (Middle, Bottom) + Individual EXH (Middle, Bottom)                                   | ① AXT632-17-16 (M3 x 137)<br>② AXT632-41-3 (M3 x 103)                 | 3<br>2  | For manifold   |  |
|   |  |   |   |  |  |
|   | Valve + Spacer (Top): Interface regulator (Middle); "Individual SUP or Individual EXH"/"Restrictor" (Bottom); "Restrictor"/"Individual SUP or Individual EXH" (Bottom) | ① AXT632-17-16 (M3 x 137)<br>② AXT632-41-3 (M3 x 103)                 | 3<br>2  | For manifold<br>The individual EXH and restrictor can be mounted on the top. |  |
|   |  |   |   |  |  |
| Valve + Double check spacer with residual pressure exhaust (Top) + SUP stop valve (Middle) + Individual SUP (EXH) (Bottom)      | ① AXT632-17-16 (M3 x 137)<br>② AXT632-41-3 (M3 x 103)  | 3<br>2  | For manifold  |  |  |
|   |  |   |   |  |  |
| Valve + Interface regulator (Top) + Double check spacer with residual pressure exhaust (Middle) + Individual SUP (EXH) (Bottom) | ① AXT632-17-20 (M3 x 162)<br>② AXT632-41-5 (M3 x 128)  | 3<br>2  | For manifold<br>available as special order          |  |  |
|   |  |   |   |  |  |

(Note) When the SUP stop valve and individual SUP are mounted, the stop valve is mounted on the top of the individual SUP.

SV  
SYJ  
SZ  
VF  
VP4  
VQ 1/2  
VQ 4/5  
VQC 1/2  
VQC 4/5  
VQZ  
SQ  
VFS  
VFR  
VQ7



# VQC4000 Series

## Specific Product Precautions 1

Be sure to read this before handling the products.

Refer to back page 50 for Safety Instructions and pages 3 to 9 for 3/4/5 Port Solenoid Valve Precautions.

### Continuous Duty

#### Warning

When the product is continuously energized for a long period of time (10 minutes or longer), select the low wattage type (DC specification). The AC type cannot be continuously energized for 10 minutes or longer. If anything is unclear, please contact SMC.

### Manual Override

#### Warning

Since connected equipment will operate when the manual override is activated, confirm that conditions are safe prior to activation.

#### ■ VQC4000

Push type (Tool required)

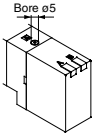

Push down the manual override button with a small screwdriver, etc., until it stops. The manual override will return when released.

Locking type (Tool required)

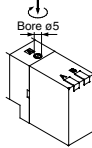

Push down the manual override button with a small flat head screwdriver until it stops, and turn it clockwise 90° to lock it. Turn it counterclockwise to release it.

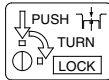

Locking type (Manual)

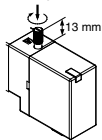

Push down the manual override button with a small flat head screwdriver or with your finger until it stops, and turn it clockwise 90° to lock it. Turn it counterclockwise to release it.

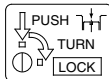

#### Caution

Do not apply excessive torque when turning the locking type manual override. (0.1 N·m or less)

### Valve Mounting

#### Caution

After confirming that the gasket is installed correctly, securely tighten the mounting screws according to the tightening torque shown below.

Proper tightening torque [N·m]  
0.8 to 1.2

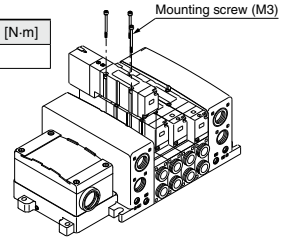

### Replacement of One-touch Fittings

#### Caution

Cylinder port fittings are available in cassette type and can be replaced easily. Fittings are secured with a retaining clip that is inserted from the top side of the valve. After removing the valve, remove the clip with a flat head screwdriver to replace the fittings. To mount a fitting, insert the fitting assembly until it stops and insert the retaining clip to its designated position.

| Applicable tube O.D. | Fitting assembly part no. |
|----------------------|---------------------------|
|                      | VQC4000                   |
| ø6                   | VVQ4000-50B-C6            |
| ø8                   | VVQ4000-50B-C8            |
| ø10                  | VVQ4000-50B-C10           |
| ø12                  | VVQ4000-50B-C12           |
| ø1/4"                | VVQ4000-50B-N7            |
| ø5/16"               | VVQ4000-50B-N9            |
| ø3/8"                | VVQ4000-50B-N11           |

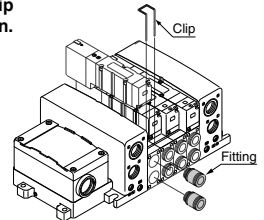

### Lead Wire Connection

#### Caution

Plug-in sub-plate (With terminal block)

- If the junction cover ① of the sub-plate is removed, you can see the plug-in type terminal block ② mounted inside the sub-plate.
- The terminal block is marked as follows. Connect wiring to each of the power supply terminals.

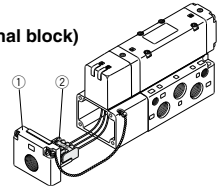

| Model         | Terminal block marking | A      | COM | B      | T |
|---------------|------------------------|--------|-----|--------|---|
| VQC 1/2 10 0  |                        | A side | COM | —      | — |
| VQC 1/2 20 0  |                        | A side | COM | B side | — |
| VQC 3/4 0 0 1 |                        | A side | COM | B side | — |

Note 1) There is no polarity. It can also be used as -COM.

Note 2) The sub-plate is double wired even for the VQC 1/2 10 0.

- Applicable terminal: 1.25-3s, 1.25Y-3, 1.25Y-3N, 1.25Y-3.5



# VQC4000 Series Specific Product Precautions 2

Be sure to read this before handling the products.  
Refer to back page 50 for Safety Instructions and pages 3 to 9 for 3/4/5 Port Solenoid Valve Precautions.

## Installation and Removal of Light Cover

### ⚠ Caution

#### Installation/Removal of light cover

##### • Removal

Open the cover by inserting a small flat head screwdriver into the slot on the side of the pilot assembly (see drawing below), lift the cover out about 1 mm and then pull off. If it is pulled off at an angle, the pilot valve may be damaged or the protective O-ring may be scratched.

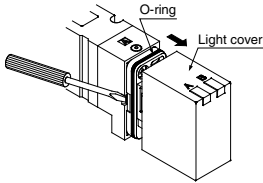

##### • Installation

Place the cover straight over the pilot assembly so that the pilot valve is not touched, and push it until the cover hook locks without twisting the protective O-ring. (When pushed in, the hook opens and locks automatically.)

## Replacement of Pilot Valve

### ⚠ Caution

##### • Removal

1) Remove the mounting screw that holds the pilot valve using a small screwdriver.

##### • Installation

1) After confirming the gasket is correctly placed under the valve, securely tighten the bolts with the proper torque shown in the table below.

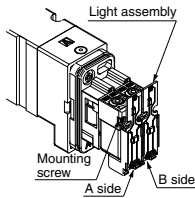

\* Refer to page 636 for pilot valve assembly part number.

## Proper tightening torque [N·m]

0.1 to 0.13

Note) The light circuit boards: A side is orange and the B side is green. It must be mounted on the pilot valve in accordance with the mounting indicators.

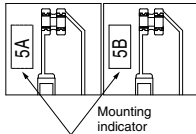

## Internal Wiring Specifications

### ⚠ Caution

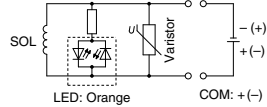

DC: Single

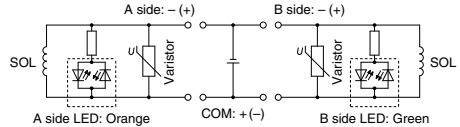

DC: Double

Note) Coil surge voltage generated when OFF is about -60 V. Please contact SMC separately for further suppression of the coil surge voltage.

## How to Calculate the Flow Rate

For obtaining the flow rate, refer to flont matter.

|         |
|---------|
| SV      |
| SYJ     |
| SZ      |
| VF      |
| VP4     |
| VQ 1/2  |
| VQ 4/5  |
| VQC 1/2 |
| VQC 4/5 |
| VQZ     |
| SQ      |
| VFS     |
| VFR     |
| VQ7     |



## VQC4000 Series

# Specific Product Precautions 3

Be sure to read this before handling the products.

Refer to back page 50 for Safety Instructions and pages 3 to 9 for 3/4/5 Port Solenoid Valve Precautions.

### Serial Wiring EX500/EX260/EX250/EX126 Precautions

## ⚠ Warning

1. These products are intended for use in general factory automation equipment.  
Avoid using these products in machinery/equipment which affects human safety, and in cases where malfunction or failure can result in extensive damage.
2. Do not use in explosive environments, in the presence of inflammable gases, or in corrosive environments. This can cause injury or fire.
3. Work such as transporting, installing, piping, wiring, operation, control and maintenance should be performed by knowledgeable and qualified personnel only. As handling involves the risk of a danger of electrocution, injury or fire.
4. Install an external emergency stop circuit that can promptly stop operation and shut off the power supply.
5. Do not modify these products. Modifications done to these products carry the risk of injury and damage.

## ⚠ Caution

1. Read the Operation Manual carefully, strictly observe the precautions and operate within the range of the specifications.
2. Do not drop these products or submit them to strong impacts. This can cause damage, failure or malfunction.
3. In locations with poor electrical conditions, take steps to ensure a steady flow of the rated power supply. Use of a voltage outside of the specifications can cause a malfunction, damage to the Unit, electrocution or fire.
4. Do not touch connector terminals or internal circuit elements when current is being supplied. There is a danger of malfunction, damage to the Unit or electrocution if connector terminals or internal circuit elements are touched when current is being supplied.  
Be sure that the power supply is OFF when adding or removing manifold valves or input blocks or when connecting or disconnecting connectors.
5. Operate at an ambient temperature that is within the specifications. Even when the ambient temperature range is within the specifications, do not use in locations where there are rapid temperature changes.
6. Keep wire scraps and other extraneous materials from getting inside these products. This can cause fire, failure or malfunction.
7. Give consideration to the operating environment depending on the type of enclosure being used.  
To achieve IP67 protection, provide appropriate wiring between all Units using electrical wiring cables, communication connectors and cables with M12 connectors. Also, provide waterproof caps when there are unused ports, and perform proper mounting of Input Units, input blocks, SI Units and manifold valves. Provide a cover or other protection for applications in which there is constant exposure to water.
8. Use the proper tightening torques.  
There is a possibility of damaging threads if tightening exceeds the tightening torque range.
9. Provide adequate protection when operating in locations such as the following:
  - Where noise is generated by static electricity
  - Where there is a strong electric field
  - Where there is a danger of exposure to radiation
  - When in close proximity to power supply lines

## ⚠ Caution

10. When these products are installed in equipment, provide adequate protection against noise by using noise filters.
11. Since these products are components whose end usage is obtained after installation in other equipment, the customer should confirm conformity to EMC directives for the finished product.
12. Do not remove the name plate.
13. Perform periodic inspections and confirm normal operation, otherwise it may be impossible to guarantee safety due to unexpected malfunction or erroneous operation.
14. Take great care since the SI Unit side surface of the EX260-SPN□ may become hot, causing burn hazard.
15. Do not use in places where there are cyclic temperature changes.  
In case that the cyclic temperature is beyond normal temperature changes, the inside product unit is likely to be adversely affected.
16. Do not use in direct sunlight.  
Do not use in direct sunlight. It may cause malfunction or damage.
17. Do not use in places where there is radiated heat around it.  
Such a place is likely to cause malfunction.

### Power Supply Safety Instructions

## ⚠ Caution

1. Operation is possible with a single power supply or a separate power supply. However, be sure to provide two wiring systems (one for solenoid valves, and one for Input and Control Units). When it is UL compliant, use a class 2 power supply unit in accordance with UL1310 for a combined direct current power supply.
2. Select the proper type of enclosure according to the environment of operation.  
IP65/67 protection class is achieved when the following conditions are met.
  - 1) The Units are connected properly with wiring cable for power supply, communication connector, and cable with M12 connector.
  - 2) Suitable mounting of each Unit and manifold valve.
  - 3) Be sure to mount a seal cap on any unused connectors.
 If using in an environment that is exposed to water splashes, please take measures such as using a cover.  
For IP40 protection class, do not use in atmospheres with corrosive gas, chemicals, sea water, water, steam, or where there is direct contact with any of these.  
When EX260-SPR5/6/7/8 are connected, the enclosure of the manifold should be IP40.

### Cable Safety Instructions

## ⚠ Caution

1. Avoid miswiring, as this can cause a malfunction, damage and fire in the Unit.
2. To prevent noise and surge in signal lines, keep all wiring separate from power lines and high voltage lines. Otherwise, this can cause a malfunction.
3. Check wiring insulation, as defective insulation can cause damage to the Unit when excessive voltage or current is applied.
4. Do not bend or pull cables repeatedly, and do not place heavy objects on them or allow them to be pinched. This can cause broken lines.



# VQC4000 Series

## Specific Product Precautions 4

Be sure to read this before handling the products.

Refer to back page 50 for Safety Instructions and pages 3 to 9 for 3/4/5 Port Solenoid Valve Precautions.

### EX600 Precautions

#### Design / Selection

#### Warning

- Do not use beyond the specification range.**  
Using beyond the specification range can cause a fire, malfunction, or damage to the system.  
Check the specifications before operation.
- When using for an interlock circuit:**
  - Provide a multiple interlock system which is operated by another system (such as mechanical protection function).
  - Perform an inspection to confirm that it is working properly.

Otherwise, this may cause possible injuries due to malfunction.

#### Caution

- When applicable to UL, use a Class 2 power supply unit conforming to UL1310 for direct current power supply.**
- Use within the specified voltage range.**  
Using beyond the specified voltage range is likely to cause the product to be damaged or to malfunction.
- The power supply for the unit should be 0 V as the standard for both power supply for output as well as power supply for control/input.**

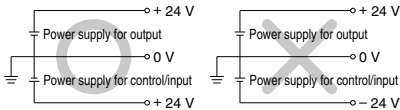

- Do not install in places where it can be used as a foothold.**  
Applying any excessive load such as stepping on the product by mistake or placing a foot on it, will cause it to break.
- Keep the surrounding space free for maintenance.**  
When designing a system, take into consideration the amount of free space needed for performing maintenance.
- Do not remove the name plate.**  
Improper maintenance or incorrect use of Operation Manual can cause equipment failure or malfunction. Also, there is a risk of losing conformity with safety standards.
- Beware of inrush current when the power supply is turned on.**  
Some connected loads can apply an initial charge current which will trigger the over current protection function, causing the Unit to malfunction.

#### Mounting

#### Caution

- When handling and assembling Units:**
  - Do not touch the sharp metal parts of the connector or plug.
  - Do not apply excessive force to the Unit when disassembling.  
The connecting portions of the Unit are firmly joined with seals.
  - When joining Units, take care not to get fingers caught between Units.  
Injury can result.
- Do not drop, bump, or apply excessive impact.**  
Otherwise, this can cause damage, equipment failure or malfunction.
- Observe the tightening torque range.**  
Tightening outside of the allowable torque range will likely damage the screw.  
IP67 cannot be guaranteed if the screws are not tightened to the specified torque.
- When lifting a large size Manifold Solenoid Valve Unit, take care to avoid causing stress to the valve connection joint.**  
The connection joint with the Unit may be damaged. Because the product may be heavy, carrying and installation should be performed by more than one operator to avoid strain or injury.
- When placing a manifold, mount it on a flat surface.**  
Torsion in the whole manifold can lead to trouble such as air leakage or contact failure.

#### Wiring

#### Caution

- Provide the grounding to maintain the safety of the reduced wiring system and to improve the noise immunity.**  
Provide a specific grounding as close to the Unit as possible to minimize the distance to grounding.
- Avoid repeatedly bending or stretching the cable and applying a heavy object or force to it.**  
Wiring applying repeated bending and tensile stress to the cable can break the circuit.
- Avoid miswiring.**  
If miswired, there is a danger of malfunction or damage to the reduced wiring system.

|         |
|---------|
| SV      |
| SYJ     |
| SZ      |
| VF      |
| VP4     |
| VQ 1/2  |
| VQ 4/5  |
| VQC 1/2 |
| VQC 4/5 |
| VQZ     |
| SQ      |
| VFS     |
| VFR     |
| VQ7     |



## VQC4000 Series

# Specific Product Precautions 5

Be sure to read this before handling the products.

Refer to back page 50 for Safety Instructions and pages 3 to 9 for 3/4/5 Port Solenoid Valve Precautions.

### EX600 Precautions

#### Wiring

#### Caution

- Do not wire while energizing the product.**  
There is a danger of malfunction or damage to the reduced wiring system or input/output device.
- Avoid wiring the power line and high pressure line in parallel.**  
Noise or surge produced by signal line resulting from the power line or high pressure line could cause a malfunction. Wiring of the reduced wiring system or input/output device and the power line or high pressure line should be separated from each other.
- Check for the wiring insulation.**  
Defective insulation (contact with other circuits, improper insulation between terminals, etc.) may cause damage to the reduced wiring system or input/output device due to excessive voltage or current.
- When the reduced wiring system is installed in machinery/equipment, provide adequate protection against noise by using noise filters etc.**  
Noise in signal lines may cause a malfunction.
- When connecting wires of input/output device or Handheld Terminal, prevent water, solvent or oil from entering inside from the connector section.**  
Otherwise, this can cause damage, equipment failure or malfunction.
- Avoid wiring patterns in which excessive stress is applied to the connector.**  
This may cause equipment failure or malfunction due to contact failure.

#### Operating Environment

#### Warning

- Do not use in an atmosphere containing an inflammable gas or explosive gas.**  
Use in such an atmosphere is likely to cause a fire or explosion. This system is not explosion-proof.

#### Caution

- Select the proper type of enclosure according to the environment of operation.**  
IP65/67 is achieved when the following conditions are met.
  - Provide appropriate wiring between Units using electrical wiring cables, communication connectors and cables with M12 connectors.
  - Suitable mounting of each Unit and manifold valve.
  - Be sure to mount a seal cap on any unused connectors.
 If using in an environment that is exposed to water splashes, please take measures such as using a cover.  
When the enclosure is IP40, do not use in an operating environment or atmosphere where it may come in contact with corrosive gas, chemical agents, seawater, water, or water vapor. When connected to the EX600-D□□E or EX600-D□□F, manifold enclosure is IP40.  
Also, the Handheld Terminal conforms to IP20, so prevent foreign matter from entering inside, and water, solvent or oil from coming in direct contact with it.

#### Operating Environment

#### Caution

- Provide adequate protection when operating in locations such as the following.**  
Failure to do so may cause a malfunction or equipment failure. The effect of countermeasures should be checked in individual equipment and machine.
  - Where noise is generated by static electricity etc.
  - Where there is a strong electric field
  - Where there is a danger of exposure to radiation
  - When in close proximity to power supply lines
- Do not use in an environment where oil and chemicals are used.**  
Operating in environments with coolants, cleaning solvents, various oils or chemicals may cause adverse effects (damage, malfunction) to the Unit even in a short period of time.
- Do not use in an environment where the product could be exposed to corrosive gas or liquid.**  
This may damage the Unit and cause it to malfunction.
- Do not use in locations with sources of surge generation.**  
Installation of the Unit in an area around the equipment (electromagnetic lifters, high frequency induction furnaces, welding machine, motors, etc.), which generates the large surge voltage could cause to deteriorate an internal circuitry element of the Unit or result in damage. Implement countermeasures against the surge from the generating source, and avoid touching the lines with each other.
- Use the product type that has an integrated surge absorption element when directly driving a load which generates surge voltage by relay, solenoid valves or lamp.**  
When a surge generating load is directly driven, the Unit may be damaged.
- The product is CE marked, but not immune to lightning strikes. Take measures against lightning strikes in your system.**
- Keep dust, wire scraps and other foreign matter from entering inside the product.**  
This may cause equipment failure or malfunction.
- Mount the Unit in such locations, where no vibration or shock is affected.**  
This may cause equipment failure or malfunction.
- Do not use in places where there are cyclic temperature changes.**  
In case that the cyclic temperature is beyond normal temperature changes, the internal Unit is likely to be adversely affected.
- Do not use in direct sunlight.**  
This may cause equipment failure or malfunction.
- Observe the ambient temperature range.**  
This may cause a malfunction.
- Do not use in places where there is radiated heat around it.**  
Such places are likely to cause a malfunction.



# VQC4000 Series Specific Product Precautions 6

Be sure to read this before handling the products.  
Refer to back page 50 for Safety Instructions and pages 3 to 9 for 3/4/5 Port Solenoid Valve Precautions.

## EX600 Precautions

### Adjustment / Operation

#### ⚠ Warning

1. Do not perform operation or setting with wet hands.  
There is a risk of electrical shock.

#### <Handheld Terminal>

2. Do not apply pressure to the LCD.  
There is a possibility of the crack of LCD and injuring.
3. The forced input/output function is used to change the signal status forcibly. When operating this function, be sure to check the safety of the surroundings and installation.  
This may cause, injuries or equipment damage.
4. Incorrect setting of parameters can cause a malfunction. Be sure to check the settings before use.  
This may cause injuries or equipment damage.

#### ⚠ Caution

1. Use a watchmakers' screwdriver with thin blade for the setting of each switch of the SI Unit.  
When setting the switch, do not touch other unrelated parts.  
This may cause parts damage or malfunction due to a short circuit.
2. Provide adequate setting for the operating conditions.  
Failure to do so could result in malfunction.  
Refer to the Operation Manual for setting of the switches.
3. For details on programming and address setting, refer to the manual from the PLC manufacturer.  
The content of programming related to protocol is designed by the manufacturer of the PLC used.

#### <Handheld Terminal>

4. Do not press the setting buttons with a sharp pointed object.  
This may cause damage or equipment failure.
5. Do not apply excessive load and impact to the setting buttons.  
This may cause damage, equipment failure or malfunction.

When the order does not include the SI Unit, a valve plate which connects the manifold and SI Unit, is not mounted. Use attached valve holding screws and mount the valve plate.  
(Tightening torque: 0.6 to 0.7 N·m)

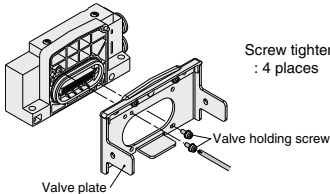

### Maintenance

#### ⚠ Warning

1. Do not disassemble, modify (including circuit board replacement) or repair this product.  
Such actions are likely to cause injuries or equipment failure.
2. When an inspection is performed,
  - Turn off the power supply.
  - Stop the air supply, exhaust the residual pressure in piping and verify that the air is released before performing maintenance work.  
Unexpected malfunction of system components and injury can result.

#### ⚠ Caution

1. When handling and replacing Units:
  - Do not touch the sharp metal parts of the connector or plug.
  - Do not apply excessive force to the Unit when disassembling.  
The connecting portions of the Unit are firmly joined with seals.
  - When joining Units, take care not to get fingers caught between Units.  
Injury can result.
2. Perform periodic inspection.  
Unexpected malfunction in the system composition devices is likely to occur due to malfunction of machinery or equipment.
3. After maintenance, make sure to perform an appropriate functionality inspection.  
In cases of abnormality such as faulty operation, stop operation. Unexpected malfunction in the system composition devices is likely to occur.
4. Do not use benzine and thinner for cleaning Units.  
Damage to the surface or erasure of the display can result. Wipe off any stains with a soft cloth.  
If the stain is persistent, wipe off with a cloth soaked in a dilute solution of neutral detergent and wrung out tightly, and then finish with a dry cloth.

### Other

#### ⚠ Caution

1. Refer to the catalog of each series for Common Precautions and Specific Product Precautions on manifold solenoid valves.

#### ■ Trademark

DeviceNet™ is a trademark of ODVA.  
EtherNet/IP™ is a trademark of ODVA.  
EtherCAT® is registered trademark and patented technology, licensed by Beckhoff Automation GmbH, Germany.

|            |
|------------|
| SV         |
| SYJ        |
| SZ         |
| VF         |
| VP4        |
| VQ<br>1/2  |
| VQ<br>4/5  |
| VQC<br>1/2 |
| VQC<br>4/5 |
| VQZ        |
| SQ         |
| VFS        |
| VFR        |
| VQ7        |

# Base Mounted

## Plug-in: Single Unit

# VQC5000 Series

### Model

| Series  | Configuration | Model           |             | Port size      | Flow rate characteristics    |     |      |                              |     |      | Response time [ms] |                         | Weight [kg] |      |
|---------|---------------|-----------------|-------------|----------------|------------------------------|-----|------|------------------------------|-----|------|--------------------|-------------------------|-------------|------|
|         |               |                 |             |                | 1 → 4/2 (P → A/B)            |     |      | 4/2 → 5/3 (A/B → EA/EB)      |     |      | Standard: 0.95 W   | Low wattage type: 0.4 W |             |      |
|         |               |                 |             |                | C [dm <sup>3</sup> /(s·bar)] | b   | Cv   | C [dm <sup>3</sup> /(s·bar)] | b   | Cv   |                    |                         |             |      |
| VQC5000 | 2-position    | Single          | Metal seal  | <b>VQC5100</b> | 1/2                          | 12  | 0.14 | 2.9                          | 14  | 0.18 | 3.4                | 35                      | 38          | 0.59 |
|         |               |                 | Rubber seal | <b>VQC5101</b> |                              | 16  | 0.33 | 4.4                          | 17  | 0.31 | 4.7                | 40                      | 43          | 0.58 |
|         |               | Double          | Metal seal  | <b>VQC5200</b> |                              | 12  | 0.14 | 2.9                          | 14  | 0.18 | 3.4                | 20                      | 23          | 0.62 |
|         |               |                 | Rubber seal | <b>VQC5201</b> |                              | 16  | 0.33 | 4.4                          | 17  | 0.31 | 4.7                | 25                      | 28          | 0.60 |
|         | 3-position    | Closed center   | Metal seal  | <b>VQC5300</b> |                              | 11  | 0.24 | 2.6                          | 11  | 0.23 | 2.8                | 50                      | 53          | 0.65 |
|         |               |                 | Rubber seal | <b>VQC5301</b> |                              | 12  | 0.33 | 3.4                          | 13  | 0.37 | 3.7                | 60                      | 63          | 0.58 |
|         |               | Exhaust center  | Metal seal  | <b>VQC5400</b> |                              | 12  | 0.13 | 2.9                          | 14  | 0.18 | 3.4                | 50                      | 53          | 0.65 |
|         |               |                 | Rubber seal | <b>VQC5401</b> |                              | 14  | 0.39 | 3.9                          | 16  | 0.35 | 4.5                | 60                      | 63          | 0.58 |
|         |               | Pressure center | Metal seal  | <b>VQC5500</b> |                              | 12  | 0.23 | 2.9                          | 13  | 0.24 | 3.3                | 50                      | 53          | 0.65 |
|         |               |                 | Rubber seal | <b>VQC5501</b> |                              | 13  | 0.32 | 3.4                          | 14  | 0.40 | 3.9                | 60                      | 63          | 0.58 |
|         |               | Double check    | Metal seal  | <b>VQC5600</b> |                              | 8.0 | —    | —                            | 8.5 | —    | —                  | 62                      | 65          | 1.17 |
|         |               |                 | Rubber seal | <b>VQC5601</b> |                              | 8.3 | —    | —                            | 9.0 | —    | —                  | 75                      | 78          | 1.10 |

Note 1) Value for valve on sub-plate

Note 2) Cylinder port 1/2: Value for valve on sub-plate

Note 3) Based on JIS B 8419: 2010. (Supply pressure: 0.5 MPa [5.1 kgf/cm<sup>2</sup>], with indicator light and surge voltage

suppressor, clean air. This will change depending on pressure and air quality.) The value when ON for the double type.

Note 4) Table: Without sub-plate, With sub-plate: Add 0.65 kg.



Plug-in unit

### Symbol

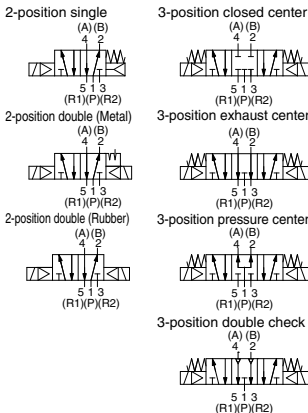

### Standard Specifications

|                               | Valve construction            | Metal seal  | Rubber seal   |          |
|-------------------------------|-------------------------------|---|---------------|----------|
|                               | Valve specifications          | Fluid   | Air/Inert gas |          |
| Max. operating pressure       |                               | 1.0 MPa   |               |          |
| Min. operating pressure       |                               | Single  | 0.10 MPa      | 0.20 MPa |
|                               |                               | Double  | 0.10 MPa      | 0.15 MPa |
|                               |                               | 3-position  | 0.15 MPa      | 0.20 MPa |
| Ambient and fluid temperature |                               | -5 to 50°C (Note 1)   |               |          |
| Lubrication                   |                               | Not required  |               |          |
| Manual override               |                               | Push type/Locking type (Tool required) Option/Locking type (Manual) |               |          |
| Impact/Vibration resistance   |                               | 150/30 m/s <sup>2</sup> (Note 2)                                    |               |          |
| Enclosure                     |                               | Dust-tight (IP67 compatible) (Note 3)                               |               |          |
| Electrical specifications     | Coil rated voltage            | 12, 24 VDC  |               |          |
|                               | Allowable voltage fluctuation | ±10% of rated voltage   |               |          |
|                               | Coil insulation type          | Class B or equivalent   |               |          |
|                               | Power consumption [W]         | 24 VDC  | 0.95, 0.4     |          |
| 12 VDC                        |                               | 0.95, 0.4   |               |          |

Note 1) Use dry air to prevent condensation when operating at low temperatures.

Note 2) Impact resistance: No malfunction occurred when it is tested with a drop tester in the axial direction and at the right angles to the main valve and armature in both energized and de-energized states every once for each condition. (Values at the initial period)

Vibration resistance: No malfunction occurred in a one-sweep test between 45 and 2000 Hz. Test was performed at both energized and de-energized states in the axial direction and at the right angles to the main valve and armature. (Values at the initial period)

Note 3) Only applicable to S, T, L and M kits



**How to Order Valves**

Plug-in

**VQC5 1 0 0 - 5 1 -**

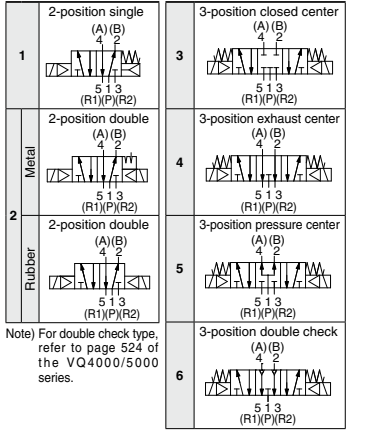

**Thread type**

|     |      |
|-----|------|
| Nil | Rc   |
| N   | NPT  |
| T   | NPTF |
| F   | G    |

**Port size**

|     |                                     |
|-----|-------------------------------------|
| Nil | Without sub-plate<br>(For manifold) |
| 04  | 1/2                                 |

**Porting specifications**

|     |               |
|-----|---------------|
| Nil | Side ported   |
| B   | Bottom ported |

**Manual override**

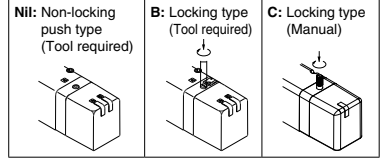

**Body**

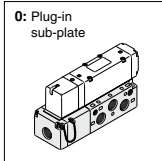

**Seal**

|   |             |
|---|-------------|
| 0 | Metal seal  |
| 1 | Rubber seal |

**Function**

|              |                          |
|--------------|--------------------------|
| Nil (Note 1) | Standard (0.95 W)        |
| Y            | Low wattage type (0.4 W) |
| R (Note 2)   | External pilot           |

Note 1) When the power is energized continuously, refer to "Specific Product Precautions 1" on page 680.  
 Note 2) For details about external pilot type, refer to page 527 of the VQ4000/5000 series. In addition, external pilot type cannot be combined with a double check spacer.  
 Note 3) When multiple symbols are specified, indicate them alphabetically.

**Light/Surge voltage suppressor**

|     |  |
|-----|--|
| Nil | Yes  |
| E   | Without light, with surge voltage suppressor |

**Coil voltage**

|   |        |
|---|--------|
| 5 | 24 VDC |
| 6 | 12 VDC |

- SV
- SYJ
- SZ
- VF
- VP4
- VQ 1/2
- VQ 4/5
- VQC 1/2
- VQC 4/5
- VQZ
- SQ
- VFS
- VFR
- VQ7



**How to Order Sub-plates**

**VQ5000 - PW - 04 -**

**Porting specifications**

|     |               |
|-----|---------------|
| Nil | Side ported   |
| B   | Bottom ported |

**CE-compliant**

|     |              |
|-----|--------------|
| Nil | -            |
| Q   | CE-compliant |

**Port size**

|    |     |
|----|-----|
| 04 | 1/2 |
|----|-----|

**Thread type**

|     |      |
|-----|------|
| Nil | Rc   |
| N   | NPT  |
| T   | NPTF |
| F   | G    |

Note) For bottom ported, port size is 1/2 only.

**Replacement of pilot valve assembly (Voltage)**  
 · Refer to page 678 for pilot valve assembly part numbers.  
 · Refer to page 681 for replacement method.

# VQC5000 Series

## Plug-in Type

### Conduit terminal

#### 2-position single: VQC510<sup>0</sup>

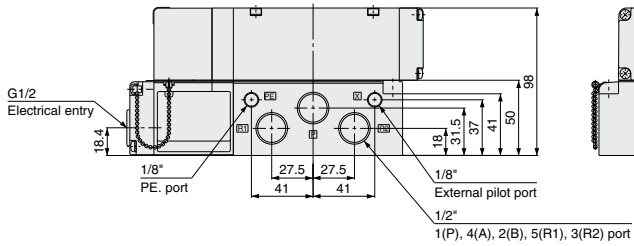
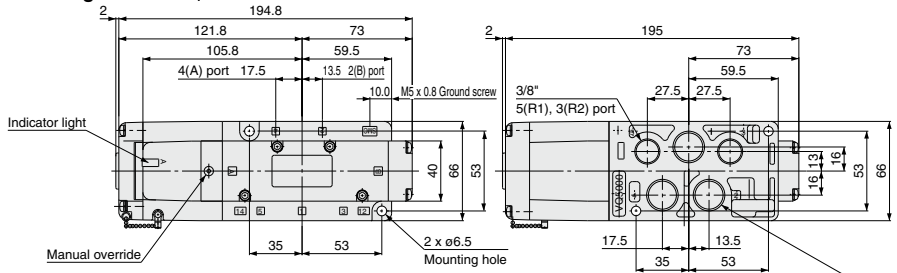

#### 2-position double: VQC520<sup>0</sup>

#### 3-position closed center: VQC530<sup>0</sup>

#### 3-position exhaust center: VQC540<sup>0</sup>

#### 3-position pressure center: VQC550<sup>0</sup>

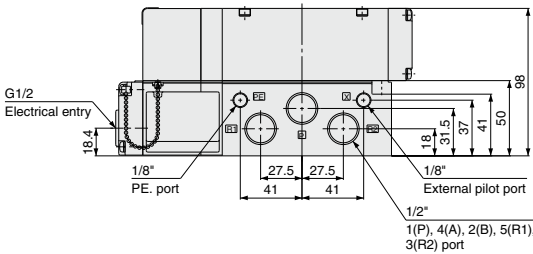
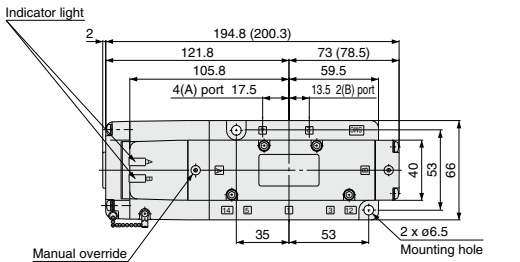

Numbers inside ( ) are for metal seal 3-position type.

#### 3-position double check: VQC560<sup>0</sup>

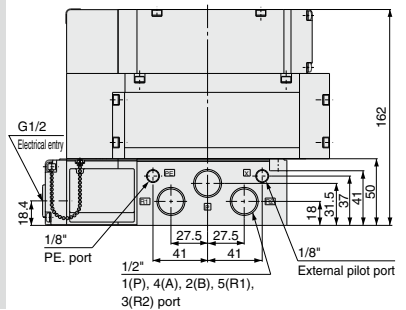
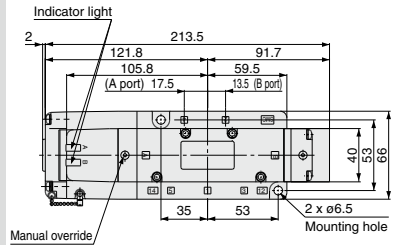

# Base Mounted

## Plug-in Unit

# VQC5000 Series

### How to Order Manifold

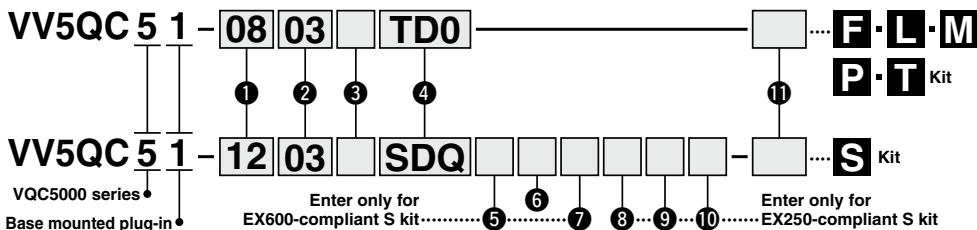

### 1 Valve stations

|    |           |
|----|-----------|
| 01 | 1 station |
| ⋮  | ⋮         |

The maximum number of stations differs depending on the electrical entry. (Refer to 1.)  
Note) In the case of compatibility with the S kit/As-Interface, the maximum number of solenoids is as shown below, so please be careful of the number of stations.  
8 in/8 out: Maximum 8 solenoids  
4 in/4 out: Maximum 4 solenoids

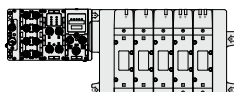

 Stations ..... 1 ..... 2 ..... 3 ..... 4 ..... 5 ..... 6 

\* Stations are counted from station 1 on the D-side.

### 2 Cylinder port size

|    |                   |
|----|-------------------|
| 03 | 3/8               |
| 04 | 1/2               |
| B  | Bottom ported 1/2 |
| CM | Mixed             |

### 3 Thread type

|     |      |
|-----|------|
| Nil | Rc   |
| F   | G    |
| N   | NPT  |
| T   | NPTF |

### 5 End plate type

(Enter only for EX600-compliant S kit.)

|     |   |
|-----|---|
| Nil | Without end plate   |
| 2   | M12 power supply connector, B-coded                           |
| 3   | 7/8 inch power supply connector                               |
| 4   | M12 power supply connector IN/OUT, A-coded, Pin arrangement 1 |
| 5   | M12 power supply connector IN/OUT, A-coded, Pin arrangement 2 |

Note) Without SI Unit, the symbol is nil.  
\* The pin layout for "4" and "5" pin connector is different.

### 6 SI Unit output polarity

| SI Unit output polarity | EX250 integrated-type (for I/O) serial transmission system |             |              |         |              |
|-------------------------|--|-------------|--------------|---------|--------------|
|                         | DeviceNet™   | PROFIBUS DP | AS-Interface | CANopen | EtherNet/IP™ |
| Nil + COM               | —  | —           | —            | —       | —            |
| N - COM                 | ○  | ○           | ○            | ○       | ○            |

| SI Unit output polarity | EX260 integrated-type (for output) serial transmission system |             |         |          |          |              |                |         |
|-------------------------|---|-------------|---------|----------|----------|--------------|----------------|---------|
|                         | DeviceNet™  | PROFIBUS DP | CC-Link | EtherCAT | PROFINET | EtherNet/IP™ | EtherPowerLink | IO-Link |
| Nil + COM               | ○   | ○           | ○       | ○        | ○        | ○            | —              | —       |
| N - COM                 | ○   | ○           | ○       | ○        | ○        | ○            | ○              | ○       |

| SI Unit output polarity | EX500 Gateway Decentralized System 2 (128 points) |          | EX500 Gateway Decentralized System (64 points) |             |              |
|-------------------------|---|----------|--|-------------|--------------|
|                         | EtherNet/IP™                                      | PROFINET | DeviceNet™                                     | PROFIBUS DP | EtherNet/IP™ |
| Nil + COM               | —   | —        | ○  | ○           | ○            |
| N - COM                 | ○   | ○        | ○  | ○           | ○            |

| SI Unit output polarity | EX600 integrated-type (for I/O) serial transmission system (Fieldbus system) |             |         |              |          |          |                                       |                                   |                 |
|-------------------------|--|-------------|---------|--------------|----------|----------|---------------------------------------|-----------------------------------|-----------------|
|                         | DeviceNet™   | PROFIBUS DP | CC-Link | EtherNet/IP™ | EtherCAT | PROFINET | EtherNet/IP™ compatible wireless base | PROFINET compatible wireless base | Wireless remote |
| Nil + COM               | ○  | ○           | ○       | ○            | ○        | ○        | ○                                     | ○                                 | ○               |
| N - COM                 | ○  | ○           | ○       | ○            | ○        | ○        | ○                                     | ○                                 | ○               |

\* Leave the box blank for without SI Unit (SD0□, SD6□).

### 7 I/O Unit stations

(Enter only for EX600-compliant S kit.)

|     |            |
|-----|------------|
| Nil | None       |
| 1   | 1 station  |
| ⋮   | ⋮          |
| 9   | 9 stations |

Note 1) Without SI Unit, the symbol is nil.  
Note 2) SI Unit is not included in I/O Unit stations.  
Note 3) When I/O Unit is selected, it is shipped separately, and assembled by customer. Refer to the attached operation manual for mounting method.  
Note 4) Refer to page 646 for details about the enclosure.

### 8 Number of input blocks

(Enter only for S kit compliant with EX250.)

|     |                       |
|-----|-----------------------|
| Nil | Without SI Unit (SD0) |
| 0   | Without input block   |
| 1   | With 1 input block    |
| ⋮   | ⋮                     |
| 4   | With 4 input blocks   |
| ⋮   | ⋮                     |
| 8   | With 8 input blocks   |

### 9 Input block type

(Enter only for S kit compliant with EX250.)

|     |                     |
|-----|---------------------|
| Nil | Without input block |
| 1   | M12, 2 inputs       |
| 2   | M12, 4 inputs       |
| 3   | M8, 4 inputs        |

### 10 Input block COM

(Enter only for S kit compliant with EX250.)

|     |   |
|-----|---|
| Nil | PNP sensor input or without input block |
| N   | NPN sensor input                        |

### 11 Option

|     |  |
|-----|--|
| Nil | None   |
| K   | Special wiring specifications (except for double wiring) |
| N   | With name plate (available for T kit only)               |

Refer to Best Pneumatics No. 1-1 and the Operation Manual for the details of EX600 Integrated-type (For I/O) Serial Transmission System. Please download the Operation Manual via our website, <http://www.smcworld.com>

4 Kit type/Electrical entry/Cable length

\*The number in parentheses indicates the maximum number of stations and the maximum number of solenoids that can be used in the case of mixed single and double wiring. The total number of solenoids determines the maximum number of stations. When ordering mixed wiring, please add the option symbol "K".

**S** Kit (Serial transmission kit (Fieldbus system) : EX600 integrated-type (for I/O))

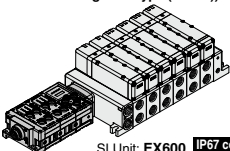

SI Unit: EX600 IP67 compliant

|       |  |                                 |
|-------|--|---------------------------------|
| SD60  | Serial kit without SI Unit                               | 1 to 12 stations<br>(24 points) |
| SD6Q  | DeviceNet™   |                                 |
| SD6N  | PROFIBUS DP  |                                 |
| SD6V  | CC-Link  |                                 |
| SD6F  | PROFINET   |                                 |
| SD6ZE | EtherNet/IP™ (1 port)                                    |                                 |
| SD6EA | EtherNet/IP™ (2 port)                                    |                                 |
| SD6D  | EtherCAT   |                                 |
| SD6WE | EtherNet/IP™ compatible wireless base <sup>Note 5)</sup> |                                 |
| SD6WF | PROFINET compatible wireless base <sup>Note 5)</sup>     |                                 |
| SD6WS | Wireless remote <sup>Note 5)</sup>                       |                                 |

**S** Kit (Serial transmission kit: EX500 gateway-type)

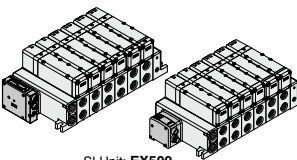

SI Unit: EX500

Note) A separate Gateway Unit and communication cable are required. IP67 compliant

|      |  |                               |  |                  |
|------|--|-------------------------------|--|------------------|
| SD0  | Serial kit without SI Unit   | —                             | —  | 1 to 12 stations |
| SDA3 | EX500 Gateway Decentralized System 2 (128 points) EtherNet/IP™, PROFINET             | 32 outputs <sup>Note 1)</sup> | 1 to 12 stations                         | 1 to 12 stations |
| SDA2 | EX500 Gateway Decentralized System (64 points) DeviceNet™, PROFIBUS DP, EtherNet/IP™ | 16 outputs                    | 1 to 8 stations (12 stations, 16 points) | 1 to 12 stations |

**S** Kit (Serial transmission kit: EX260 integrated-type (for output))

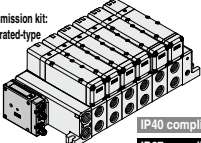

SI Unit: EX260 IP67 compliant

| Symbol | Protocol                   | Number of outputs | Communication connector  | Stations                                 |
|--------|----------------------------|-------------------|--------------------------|--|
| SD0    | Serial kit without SI Unit | —                 | —                        | 1 to 12 stations                         |
| SQA    | DeviceNet™                 | 32                | M12                      | 1 to 12 stations                         |
| SQB    | DeviceNet™                 | 16                | M12                      | 1 to 8 stations (12 stations, 16 points) |
| SNA    | PROFIBUS DP                | 32                | M12                      | 1 to 12 stations                         |
| SNC    | PROFIBUS DP                | 16                | M12                      | 1 to 8 stations (12 stations, 16 points) |
| SND    | PROFIBUS DP                | 16                | D-sub <sup>Note 3)</sup> | 1 to 12 stations                         |
| SVA    | CC-Link                    | 32                | M12                      | 1 to 12 stations                         |
| SVB    | CC-Link                    | 16                | M12                      | 1 to 8 stations (12 stations, 16 points) |
| SDA    | EtherCAT                   | 32                | M12                      | 1 to 12 stations                         |
| SDB    | EtherCAT                   | 16                | M12                      | 1 to 8 stations (12 stations, 16 points) |
| SFA    | PROFINET                   | 32                | M12                      | 1 to 12 stations                         |
| SFB    | PROFINET                   | 16                | M12                      | 1 to 8 stations (12 stations, 16 points) |
| SEA    | EtherNet/IP™               | 32                | M12                      | 1 to 12 stations                         |
| SEB    | EtherNet/IP™               | 16                | M12                      | 1 to 8 stations (12 stations, 16 points) |
| SGA    | Ethernet                   | 32                | M12                      | 1 to 12 stations                         |
| SGB    | POWERLINK                  | 16                | M12                      | 1 to 8 stations (12 stations, 16 points) |
| SKA    | IO-Link                    | 32                | M12                      | 1 to 12 stations                         |

**S** Kit (Serial transmission kit: EX250 integrated-type (for I/O))

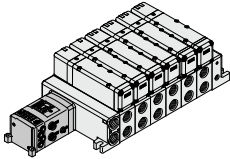

SI Unit: EX250 IP67 compliant

|                         |  |   |   |  |
|-------------------------|--|---|---|--|
| SD0                     | Serial kit without SI Unit                                     | — | — | 1 to 12 stations                       |
| SDQ                     | DeviceNet™   | — | — | 1 to 12 stations                       |
| SDN                     | PROFIBUS DP  | — | — | 1 to 12 stations                       |
| SDTA                    | AS-Interface, 8 in/out, 31 slave modes, 2 power supply systems | — | — | 1 to 4 stations (8 stations, 8 points) |
| SDTB                    | AS-Interface, 4 in/out, 31 slave modes, 2 power supply systems | — | — | 1 to 2 stations (4 stations, 4 points) |
| SDTC <sup>Note 2)</sup> | AS-Interface, 8 in/out, 31 slave modes, 1 power supply system  | — | — | 1 to 4 stations (8 stations, 8 points) |
| SDTD <sup>Note 2)</sup> | AS-Interface, 4 in/out, 31 slave modes, 1 power supply system  | — | — | 1 to 2 stations (4 stations, 4 points) |
| SDY                     | CANopen  | — | — | 1 to 12 stations                       |
| SDZEN                   | EtherNet/IP™   | — | — | 1 to 12 stations                       |

|                         |  |   |   |  |
|-------------------------|--|---|---|--|
| SD0                     | Serial kit without SI Unit                                     | — | — | 1 to 12 stations                       |
| SDQ                     | DeviceNet™   | — | — | 1 to 12 stations                       |
| SDN                     | PROFIBUS DP  | — | — | 1 to 12 stations                       |
| SDTA                    | AS-Interface, 8 in/out, 31 slave modes, 2 power supply systems | — | — | 1 to 4 stations (8 stations, 8 points) |
| SDTB                    | AS-Interface, 4 in/out, 31 slave modes, 2 power supply systems | — | — | 1 to 2 stations (4 stations, 4 points) |
| SDTC <sup>Note 2)</sup> | AS-Interface, 8 in/out, 31 slave modes, 1 power supply system  | — | — | 1 to 4 stations (8 stations, 8 points) |
| SDTD <sup>Note 2)</sup> | AS-Interface, 4 in/out, 31 slave modes, 1 power supply system  | — | — | 1 to 2 stations (4 stations, 4 points) |
| SDY                     | CANopen  | — | — | 1 to 12 stations                       |
| SDZEN                   | EtherNet/IP™   | — | — | 1 to 12 stations                       |

**S** Kit (Serial transmission kit: EX126 integrated-type (for output))

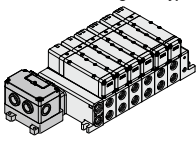

SI Unit: EX126 IP67 compliant

|      |                        |  |
|------|------------------------|--|
| SDVB | Serial kit for CC-Link | 1 to 8 stations (12 stations, 16 points) |
|------|------------------------|--|

**P** Kit (Flat ribbon cable kit)

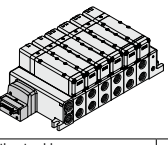

SI Unit: EX126 IP67 compliant

Note) For a 20P flat ribbon cable, the cable assembly must be ordered separately. IP40 compliant

|     |  |                  |
|-----|--|------------------|
| PD0 | Flat ribbon cable kit (26P) without cable                    | 1 to 12 stations |
| PD1 | Flat ribbon cable kit (26P) with 1.5 m cable                 |                  |
| PD2 | Flat ribbon cable kit (26P) with 3.0 m cable                 |                  |
| PD3 | Flat ribbon cable kit (26P) with 5.0 m cable                 |                  |
| PDC | Flat ribbon cable kit (20P) without cable <sup>Note 3)</sup> |                  |

**F** Kit (D-sub connector kit)

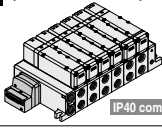

SI Unit: EX126 IP67 compliant

|     |  |                  |
|-----|--|------------------|
| FD0 | D-sub connector kit (25P) without cable    | 1 to 12 stations |
| FD1 | D-sub connector kit (25P) with 1.5 m cable |                  |
| FD2 | D-sub connector kit (25P) with 3.0 m cable |                  |
| FD3 | D-sub connector kit (25P) with 5.0 m cable |                  |

**M** Kit (Circular connector kit)

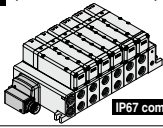

SI Unit: EX126 IP67 compliant

|     |   |                  |
|-----|---|------------------|
| MD0 | Circular connector kit (26P) without cable    | 1 to 12 stations |
| MD1 | Circular connector kit (26P) with 1.5 m cable |                  |
| MD2 | Circular connector kit (26P) with 3.0 m cable |                  |
| MD3 | Circular connector kit (26P) with 5.0 m cable |                  |

**T** Kit (Terminal block box kit)

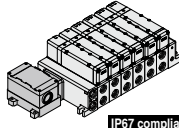

SI Unit: EX126 IP67 compliant

|     |                        |   |
|-----|------------------------|---|
| TD0 | Terminal block box kit | 1 to 10 stations (12 stations, 20 points) |
|-----|------------------------|---|

**L** Kit (Lead wire kit)

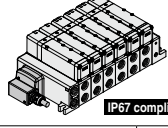

SI Unit: EX126 IP67 compliant

|     |                                |                  |
|-----|--------------------------------|------------------|
| LD0 | Lead wire kit, 0.6 m lead wire | 1 to 12 stations |
| LD1 | Lead wire kit, 1.5 m lead wire |                  |
| LD2 | Lead wire kit, 3.0 m lead wire |                  |

\*The maximum number of stations and the maximum number of solenoids indicated in parentheses are applied to special wiring specifications only (Option "K").  
 Note 1) When using the SI Unit with 32 outputs, use the GW Unit compatible with the EX500 Gateway Decentralized System 2 (128 points).

Note 2) When selecting SI Units with SDTC or SDTD specifications, there are limits to the supply current from the SI Unit to the input block or valve. For details, refer to page 805 in Best Pneumatics No. 1-1.

Note 3) When selecting D-sub 5 kit specifications only, IP40 is compatible. (All other SI Units are IP67 compliant).  
 Note 4) For the SI Unit part no., refer to page 655.  
 Note 5) The wireless system is suitable for use only in a country where it is in accordance with the Radio Act and regulations of that country.

SV  
SYJ  
SZ  
VF  
VP4  
VQ 1/2  
VQ 4/5  
VQC 1/2  
VQC 4/5  
VQZ  
SQ  
VFS  
VFR  
VQ7

# VQC5000 Series

## How to Order Valves

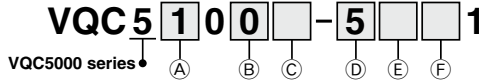

### (A) Type of actuation

|          |   |   |
|----------|---|---|
| <b>1</b> | 2-position single<br>(A) (B)<br>4 2<br><br>(R1) (P) (R2)          | 3-position exhaust center<br>(A) (B)<br>4 2<br><br>(R1) (P) (R2)  |
|          | 2-position double (Metal)<br>(A) (B)<br>4 2<br><br>(R1) (P) (R2)  | 3-position pressure center<br>(A) (B)<br>4 2<br><br>(R1) (P) (R2) |
| <b>2</b> | 2-position double (Rubber)<br>(A) (B)<br>4 2<br><br>(R1) (P) (R2) | 3-position double check<br>(A) (B)<br>4 2<br><br>(R1) (P) (R2)    |
|          | 3-position closed center<br>(A) (B)<br>4 2<br><br>(R1) (P) (R2)   |   |

### (B) Seal type

|          |             |
|----------|-------------|
| <b>0</b> | Metal seal  |
| <b>1</b> | Rubber seal |

### (C) Function

|                     |                          |
|---------------------|--------------------------|
| <b>Nil</b> (Note 1) | Standard (0.95 W)        |
| <b>Y</b>            | Low wattage type (0.4 W) |
| <b>R</b> (Note 2)   | External pilot           |

Note 1) When the power is energized continuously, refer to "Specific Product Precautions 1" on page 680.

Note 2) For details about external pilot type, refer to page 527 of the VQ4000/5000 series.

\* When multiple symbols are specified, indicate them alphabetically.

### (D) Coil voltage

|          |               |
|----------|---------------|
| <b>5</b> | 24 VDC (Note) |
| <b>6</b> | 12 VDC        |

Note) S kit is only available for 24 VDC.

### (E) Light/Surge voltage suppressor

|            |  |
|------------|--|
| <b>Nil</b> | Yes  |
| <b>E</b>   | Without light, with surge voltage suppressor |

### (F) Manual override

|            |  |  |
|------------|--|--|
| <b>Nil</b> | Non-locking push type (Tool required)  |  |
| <b>B</b>   | Push-turn locking type (Tool required) |  |
| <b>C</b>   | Turn locking type (Manual)             |  |

## How to Order Manifold Assembly

### Example (VV5QC51-□SD6□)

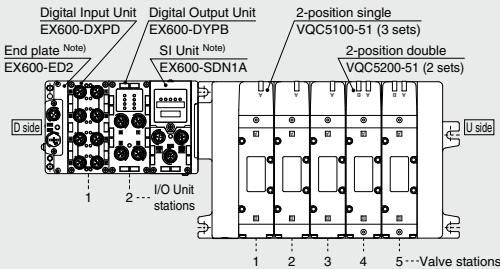

VV5QC51-0503SD6Q2N2...1 set (S kit 5-station manifold base part number)

=VQC5100-51.....3 sets (2-position single part number)

=VQC5200-51.....2 sets (2-position double part number)

=EX600-DXPD.....1 set I/O Unit part number (Station 1)

=EX600-DYPB.....1 set I/O Unit part number (Station 2)

\* The asterisk denotes the symbol for assembly.  
\* Prefix it to the part numbers of the valve etc.

The valve arrangement is numbered as the 1st station from the D side.  
Under the manifold part number, state the valves to be mounted, then the I/O Units in order from the 1st station as shown in the figure above. If the arrangement becomes complicated, specify on a manifold specification sheet.

Note) Do not enter the SI Unit part number and the end plate part number together.

## Manifold Specifications

| Series  | Base model  | Connection type  | Piping specifications |  | Note 2) Applicable stations   | Applicable solenoid valve  | 5-station weight [g]     |  |
|---------|-------------|--|-----------------------|--|-------------------------------|--|--------------------------|--|
|         |             |  | Port direction        | Port size (Note 1)   |                               |  |                          |  |
|         |             |  |                       | 1, 3 (P, R)  |                               |  |                          | 2, 4 (A, B)  |
| VQC5000 | VV5QC51-□□□ | <ul style="list-style-type: none"> <li>■ F kit: D-sub connector</li> <li>■ P kit: Flat ribbon cable</li> <li>■ T kit: Terminal block box</li> <li>■ S kit: Serial transmission</li> <li>■ L kit: Lead wire</li> <li>■ M kit: Circular connector</li> </ul> | Side                  | [D side]<br>P: 1/2 R: 1/2<br>(Rc, G, NPT/NPTF)<br>[U side]<br>P: 3/8 R: 3/8<br>(Rc, G, NPT/NPTF) | 3/8, 1/2<br>(Rc, G, NPT/NPTF) | ( F, L, M, P kit<br>1 to 12 stations)<br>( T kit<br>1 to 10 stations)<br>S kit<br>1 to 12 stations: EX250, EX260<br>1 to 12 stations: EX500, EX600 | VQC5□00-51<br>VQC5□01-51 | 4330<br>S kit<br>(Without Unit)<br>Not including valve weight. |
|         |             |  | Bottom                | 1/2<br>(Rc, G, NPT/NPTF)   |                               |  |                          |  |

Note 1) One-touch fittings in inch sizes are also available.

Note 2) As an optional specification, the maximum number of stations can be increased by special wiring specifications.

SI Unit Part Number Table

EX600

| Symbol | Applicable protocol                         | SI Unit part no.      |                       | Page |
|--------|---|-----------------------|-----------------------|------|
|        |   | Negative common (PNP) | Positive common (NPN) |      |
| SD6Q   | DeviceNet™                                  | EX600-SDN1A           | EX600-SDN2A           | 638  |
| SD6N   | PROFIBUS DP                                 | EX600-SPR1A           | EX600-SPR2A           |      |
| SD6V   | CC-Link                                     | EX600-SMJ1            | EX600-SMJ2            |      |
| SD6F   | PROFINET                                    | EX600-SPN1            | EX600-SPN2            |      |
| SD6ZE  | EtherNet/IP™ (1 port)                       | EX600-SEN1            | EX600-SEN2            |      |
| SD6EA  | EtherNet/IP™ (2 port)                       | EX600-SEN3            | EX600-SEN4            |      |
| SD6D   | EtherCAT                                    | EX600-SEC1            | EX600-SEC2            |      |
| SD6WE  | EtherNet/IP™ compatible wireless base (NPN) | EX600-WEN1            | EX600-WEN2            |      |
| SD6WF  | PROFINET compatible wireless base (NPN)     | EX600-WPN1            | EX600-WPN2            |      |
| SD6WS  | Wireless remote (NPN)                       | EX600-WSV1            | EX600-WSV2            |      |

Note) The wireless system is suitable for use only in a country where it is in accordance with the Radio Act and regulations of that country.

EX260

| Symbol | Applicable protocol | Number of outputs | SI Unit part no.      |                       | Communication connector | Page |
|--------|---------------------|-------------------|-----------------------|-----------------------|-------------------------|------|
|        |                     |                   | Negative common (PNP) | Positive common (NPN) |                         |      |
| SQA    | DeviceNet™          | 32                | EX260-SDN1            | EX260-SDN2            | M12                     | 638  |
| SQB    |                     | 16                | EX260-SDN3            | EX260-SDN4            |                         |      |
| SNA    | PROFIBUS DP         | 32                | EX260-SPR1            | EX260-SPR2            | D-sub                   |      |
| SNB    |                     | 16                | EX260-SPR3            | EX260-SPR4            |                         |      |
| SNC    | CC-Link             | 32                | EX260-SPR5            | EX260-SPR6            | M12                     |      |
| SND    |                     | 16                | EX260-SPR7            | EX260-SPR8            |                         |      |
| SVA    | EtherCAT            | 32                | EX260-SMJ1            | EX260-SMJ2            | M12                     |      |
| SVB    |                     | 16                | EX260-SMJ3            | EX260-SMJ4            |                         |      |
| SDA    | PROFINET            | 32                | EX260-SEC1            | EX260-SEC2            | M12                     |      |
| SDB    |                     | 16                | EX260-SEC3            | EX260-SEC4            |                         |      |
| SFA    | EtherNet/IP™        | 32                | EX260-SPN1            | EX260-SPN2            | M12                     |      |
| SFB    |                     | 16                | EX260-SPN3            | EX260-SPN4            |                         |      |
| SEA    | EtherNet/IP™        | 32                | EX260-SEN1            | EX260-SEN2            | M12                     |      |
| SEB    |                     | 16                | EX260-SEN3            | EX260-SEN4            |                         |      |
| SGA    | POWERLINK           | 32                | EX260-SPL1            | —                     | M12                     |      |
| SGB    |                     | 16                | EX260-SPL3            | —                     |                         |      |
| SKA    | IO-Link             | 32                | EX260-SIL1            | —                     | M12                     |      |

EX126

| Symbol | Applicable protocol            | SI Unit part no. | Page |
|--------|--------------------------------|------------------|------|
| SDVB   | CC-Link, Positive common (NPN) | EX126D-SMJ1      | 639  |

EX500 Gateway Decentralized System 2 (128 points)

| Symbol | Applicable protocol      | SI Unit part no.      |  | Page |
|--------|--------------------------|-----------------------|--|------|
|        |                          | Negative common (PNP) |  |      |
| SDA3   | EtherNet/IP™<br>PROFINET | EX500-S103            |  | 638  |

EX500 Gateway Decentralized System (64 points)

| Symbol | Applicable protocol                       | SI Unit part no.      |                       | Page |
|--------|---|-----------------------|-----------------------|------|
|        |   | Positive common (NPN) | Negative common (PNP) |      |
| SDA2   | DeviceNet™<br>PROFIBUS DP<br>EtherNet/IP™ | EX500-Q001            | EX500-Q101            | 638  |

EX250

| Symbol | Applicable protocol   | SI Unit part no. | Page |
|--------|---|------------------|------|
| SDQ    | DeviceNet™, Negative common (PNP)   | EX250-SDN1       | 639  |
| SDN    | PROFIBUS DP, Negative common (PNP)  | EX250-SPR1       |      |
| SDTA   | AS-Interface, Negative common (PNP), (8 in/8 out, 31 slave modes, 2 power supply systems) | EX250-SAS3       |      |
| SDTB   | AS-Interface, Negative common (PNP), (4 in/4 out, 31 slave modes, 2 power supply systems) | EX250-SAS5       |      |
| SDTC   | AS-Interface, Negative common (PNP), (8 in/8 out, 31 slave modes, 1 power supply system)  | EX250-SAS7       |      |
| SDTD   | AS-Interface, Negative common (PNP), (4 in/4 out, 31 slave modes, 1 power supply system)  | EX250-SAS9       |      |
| SDY    | CANopen, Negative common (PNP)  | EX250-SCA1A      |      |
| SDZEN  | EtherNet/IP™, Negative common (PNP)   | EX250-SEN1       |      |

For details about the EX series (Serial Transmission System), refer to Best Pneumatics No. 1-1 and the Operation Manual. Please download the Operation Manual via SMC website, <http://www.smcworld.com>

Manifold Options

For details about options, refer to page 522 or later of the VQ5000 series.

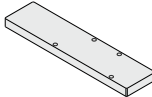
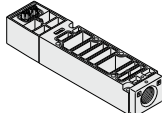
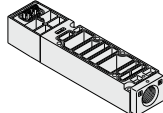
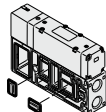
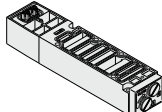
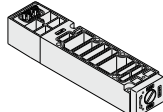
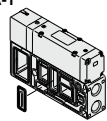
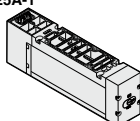
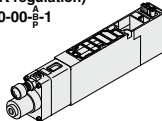
|   |   |   |
|---|---|---|
| <p>Blanking plate assembly<br/>VVQ5000-10A-1</p>                               | <p>Individual SUP spacer<br/>VVQ5000-P-1-<sup>03</sup>/<sub>04</sub></p>     | <p>Individual EXH spacer<br/>VVQ5000-R-1-<sup>03</sup>/<sub>04</sub></p>                               |
| <p>EXH block plate<br/>VVQ5000-16A-2 (1 pc./set)<br/>(Order q'ty: 2 pcs.)</p>  | <p>Restrictor spacer<br/>VVQ5000-20A-1</p>                                   | <p>SUP stop valve spacer<br/>VVQ5000-37A-1</p>   |
| <p>SUP block plate<br/>VVQ5000-16A-1</p>                                       | <p>Double check spacer with residual pressure exhaust<br/>VVQ5000-25A-1</p>  | <p>Interface regulator<br/>(P, A, B port regulation)<br/>ARBQ5000-00-<sup>03</sup>/<sub>B-1</sub></p>  |

For replacement parts, refer to page 678

# VQC5000 Series

## S VQC5000

Kit (Serial transmission kit): For EX600 Integrated-type (I/O) Serial Transmission System **IP67 compliant**

VV5QC51

S kit (Serial transmission kit: EX600)

Power supply with M12 connector

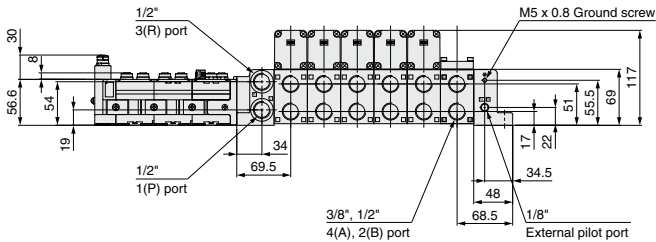
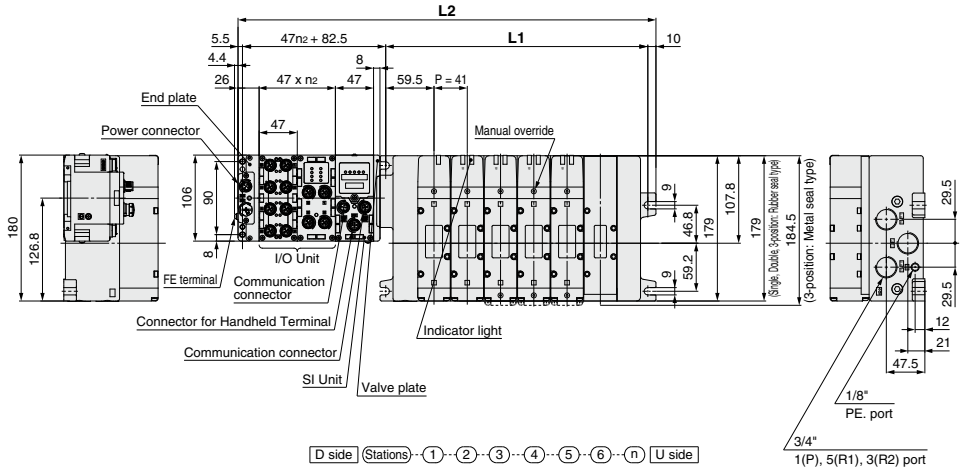

### Bottom ported

<-P/R port side>

<-Bottom side>

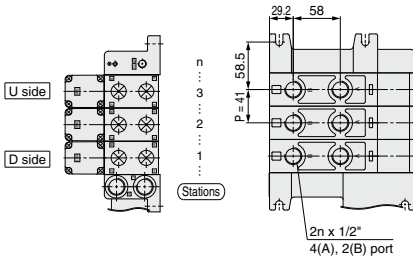

\* Other dimensions are the same as the side ported type.

### Dimensions

Formula: L1 = 41n + 77, L2 = 41n + 175 + L2 is the dimension without I/O Unit. Add 47 mm for each additional I/O Units. \* "n" is number of I/O Units. n: Stations (Maximum 12 stations)

| L \ n | 1   | 2   | 3   | 4   | 5   | 6   | 7   | 8   | 9   | 10  | 11  | 12  |
|-------|-----|-----|-----|-----|-----|-----|-----|-----|-----|-----|-----|-----|
| L1    | 118 | 159 | 200 | 241 | 282 | 323 | 364 | 405 | 446 | 487 | 528 | 569 |
| L2    | 216 | 257 | 298 | 339 | 380 | 421 | 462 | 503 | 544 | 585 | 626 | 667 |



VQC5000

Kit (Serial transmission kit): For EX600 Integrated-type (I/O) Serial Transmission System IP67 compliant

VV5QC51

S kit (Serial transmission kit: EX600)

Power supply with 7/8 inch connector

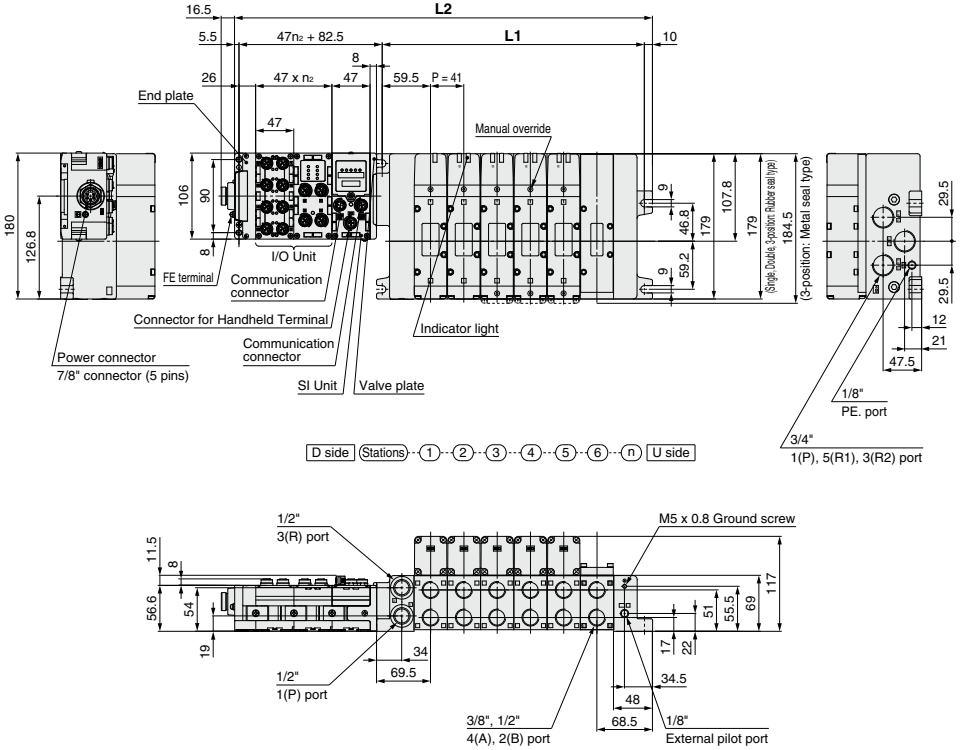

|         |
|---------|
| SV      |
| SYJ     |
| SZ      |
| VF      |
| VP4     |
| VQ 1/2  |
| VQ 4/5  |
| VQC 1/2 |
| VQC 4/5 |
| VQZ     |
| SQ      |
| VFS     |
| VFR     |
| VQ7     |

Note) The dimensions of the bottom ported type are common to all S kits.

Dimensions Formula: L1 = 41n + 77, L2 = 41n + 175 + L2 is the dimension without I/O Unit. Add 47 mm for each additional I/O Units. \* "n" is number of I/O Units. n: Stations (Maximum 12 stations)

| L  | n | 1   | 2   | 3   | 4   | 5   | 6   | 7   | 8   | 9   | 10  | 11  | 12  |
|----|---|-----|-----|-----|-----|-----|-----|-----|-----|-----|-----|-----|-----|
| L1 |   | 118 | 159 | 200 | 241 | 282 | 323 | 364 | 405 | 446 | 487 | 528 | 569 |
| L2 |   | 216 | 257 | 298 | 339 | 380 | 421 | 462 | 503 | 544 | 585 | 626 | 667 |

# VQC5000 Series

## S VQC5000

Kit (Serial transmission kit): For EX500 Gateway Decentralized System 2 (128 points) **IP67 compliant**

VV5QC51

S kit (Serial transmission kit: EX500)

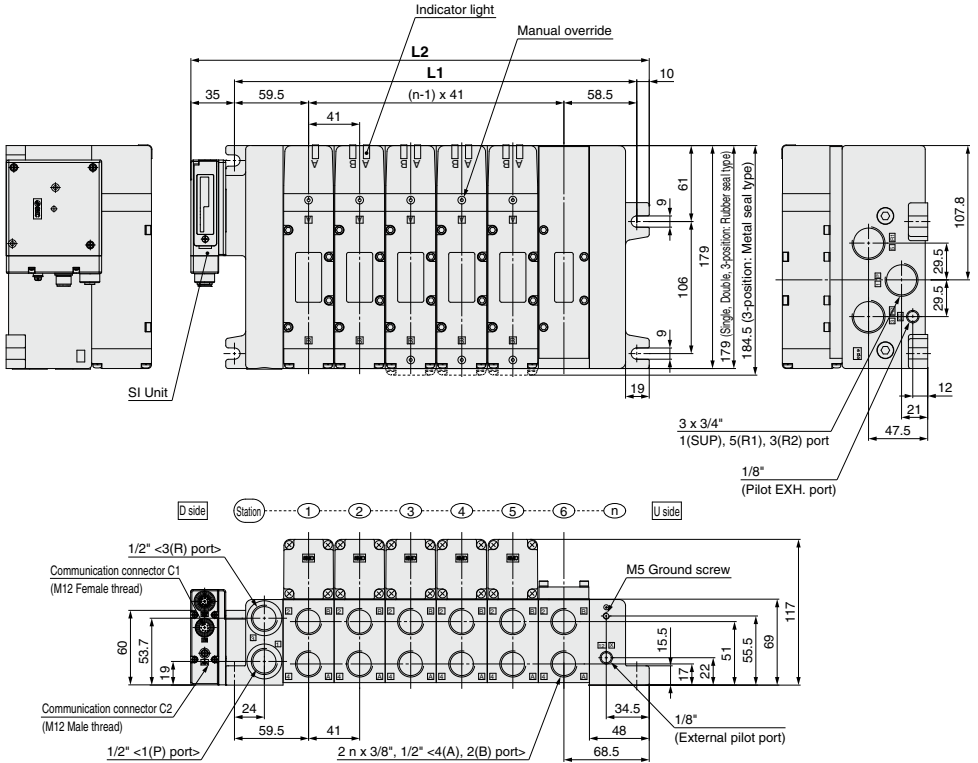

Note) The dimensions of the bottom ported type are common to all S kits.

Formula:  $L1 = 41n + 77$ ,  $L2 = 41n + 122$  n: Stations (Maximum 12 stations)

| L \ n     | 1   | 2   | 3   | 4   | 5   | 6   | 7   | 8   | 9   | 10  | 11  | 12  |
|-----------|-----|-----|-----|-----|-----|-----|-----|-----|-----|-----|-----|-----|
| <b>L1</b> | 118 | 159 | 200 | 241 | 282 | 323 | 364 | 405 | 446 | 487 | 528 | 569 |
| <b>L2</b> | 163 | 204 | 245 | 286 | 327 | 368 | 409 | 450 | 491 | 532 | 573 | 614 |



VQC5000

Kit (Serial transmission kit): For EX500 Gateway Decentralized System (64 points) IP67 compliant

VV5QC51

S kit (Serial transmission kit: EX500)

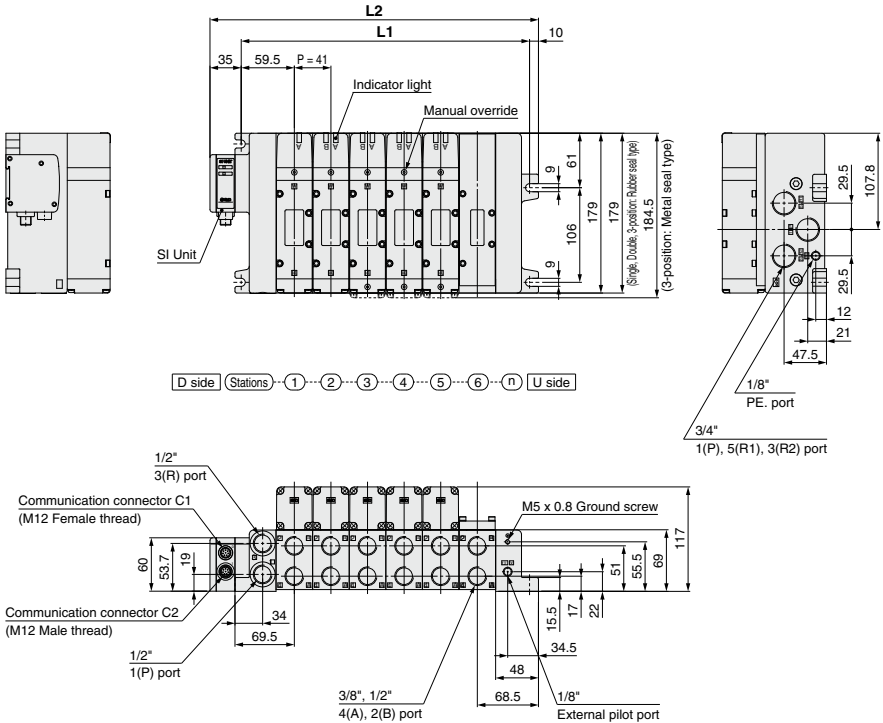

Note) The dimensions of the bottom ported type are common to all S kits.

Dimensions

Formula: L1 = 41n + 77, L2 = 41n + 122 n: Stations (Maximum 12 stations)

| L \ n | 1   | 2   | 3   | 4   | 5   | 6   | 7   | 8   | 9   | 10  | 11  | 12  |
|-------|-----|-----|-----|-----|-----|-----|-----|-----|-----|-----|-----|-----|
| L1    | 118 | 159 | 200 | 241 | 282 | 323 | 364 | 405 | 446 | 487 | 528 | 569 |
| L2    | 163 | 204 | 245 | 286 | 327 | 368 | 409 | 450 | 491 | 532 | 573 | 614 |

- SV
- SYJ
- SZ
- VF
- VP4
- VQ 1/2
- VQ 4/5
- VQC 1/2
- VQC 4/5**
- VQZ
- SQ
- VFS
- VFR
- VQ7

# VQC5000 Series

## S VQC5000

Kit (Serial transmission kit): For EX260 Integrated-type (Output) Serial Transmission System

IP40 compliant

IP67 compliant

VV5QC51

S kit (Serial transmission kit: EX260)

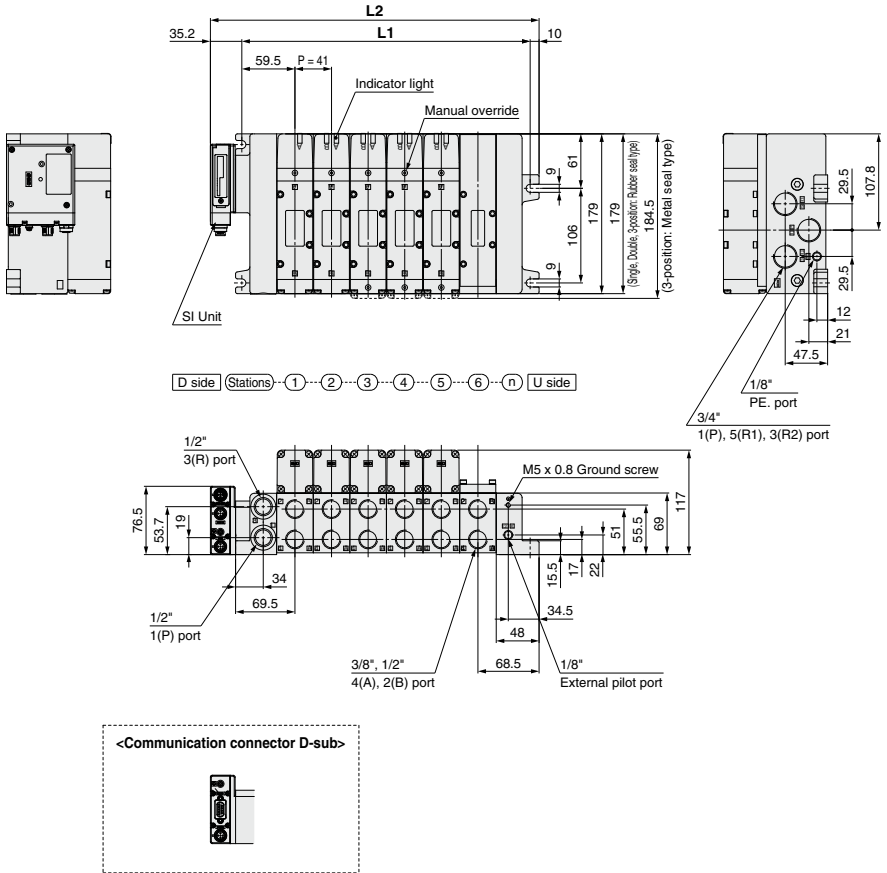

Note) The dimensions of the bottom ported type are common to all S kits.

### Dimensions

Formula:  $L_1 = 41n + 77$ ,  $L_2 = 41n + 122.2$  n: Stations (Maximum 12 stations)

| L         | n | 1     | 2     | 3     | 4     | 5     | 6     | 7     | 8     | 9     | 10    | 11    | 12    |
|-----------|---|-------|-------|-------|-------|-------|-------|-------|-------|-------|-------|-------|-------|
| <b>L1</b> |   | 118   | 159   | 200   | 241   | 282   | 323   | 364   | 405   | 446   | 487   | 528   | 569   |
| <b>L2</b> |   | 163.2 | 204.2 | 245.2 | 286.2 | 327.2 | 368.2 | 409.2 | 450.2 | 491.2 | 532.2 | 573.2 | 614.2 |



**VQC5000**

Kit (Serial transmission kit): For EX250 Integrated-type (I/O) Serial Transmission System **IP67 compliant**

VV5QC51

S kit (Serial transmission kit: EX250)

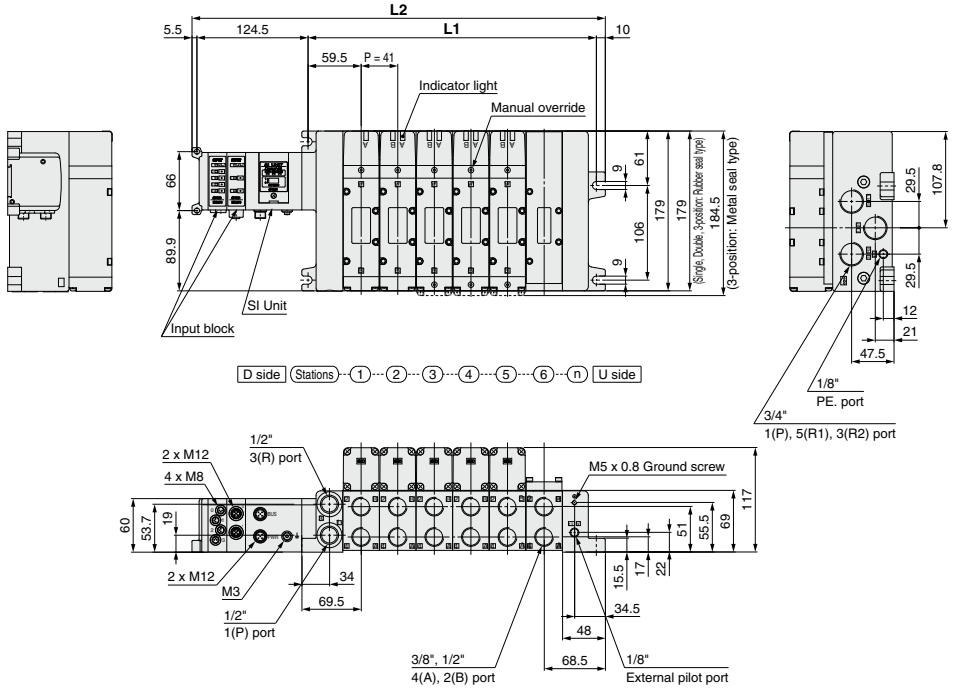

|                |
|----------------|
| SV             |
| SYJ            |
| SZ             |
| VF             |
| VP4            |
| VQ 1/2         |
| VQ 4/5         |
| VQC 1/2        |
| <b>VQC 4/5</b> |
| VQZ            |
| SQ             |
| VFS            |
| VFR            |
| VQ7            |

Note) The dimensions of the bottom ported type are common to all S kits.

**Dimensions** Formula: L1 = 41n + 77, L2 = 41n + 196 (For one input block. Add 21 mm for each additional input block.) n: Stations (Maximum 12 stations)

| L  | n | 1   | 2   | 3   | 4   | 5   | 6   | 7   | 8   | 9   | 10  | 11  | 12  |
|----|---|-----|-----|-----|-----|-----|-----|-----|-----|-----|-----|-----|-----|
| L1 |   | 118 | 159 | 200 | 241 | 282 | 323 | 364 | 405 | 446 | 487 | 528 | 569 |
| L2 |   | 237 | 278 | 319 | 360 | 401 | 442 | 483 | 524 | 565 | 606 | 647 | 688 |

# VQC5000 Series

## **S** VQC5000 Kit (Serial transmission kit): For EX126 Integrated-type (Output) Serial Transmission System **IP67 compliant**

VV5QC51  
S kit (Serial transmission kit: EX126)

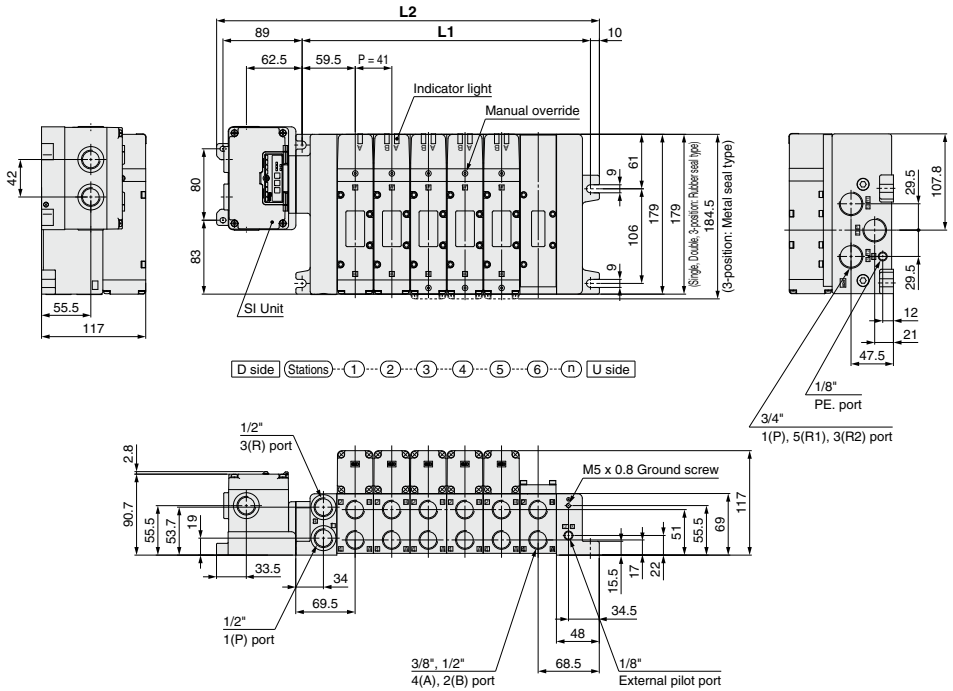

Note) The dimensions of the bottom ported type are common to all S kits.

### Dimensions

Formula:  $L1 = 41n + 77$ ,  $L2 = 41n + 182.8$  n: Stations (Maximum 12 stations)

| n  | 1     | 2     | 3     | 4     | 5     | 6     | 7     | 8     | 9     | 10    | 11    | 12    |
|----|-------|-------|-------|-------|-------|-------|-------|-------|-------|-------|-------|-------|
| L1 | 118   | 159   | 200   | 241   | 282   | 323   | 364   | 405   | 446   | 487   | 528   | 569   |
| L2 | 223.8 | 264.8 | 305.8 | 346.8 | 387.8 | 428.8 | 469.8 | 510.8 | 551.8 | 592.8 | 633.8 | 674.8 |

# VQC5000 Series

## F VQC5000 Kit (D-sub connector kit) IP40 compliant

- Using our D-sub connector for electrical connections greatly reduces labor, while it also minimizes wiring and saves space.
- We use a D-sub connector (25P) that conforms to MIL standards and is therefore widely compatible with many standard commercial models.
- Top or side entry for the connector can be changed freely, allowing for changes even after mounting, to meet any changing needs for space.

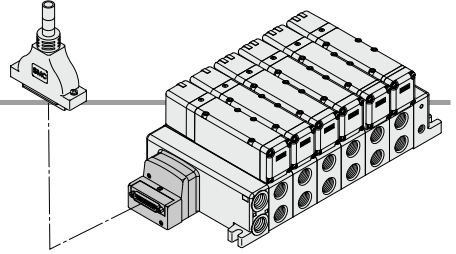

### Electrical Wiring Specifications

**D-sub connector**

As the standard electrical wiring specification used is for 12 stations or less, double wiring (connected to SOL. A and SOL. B) is used for the internal wiring of each station regardless of valve and option types. Mixed single and double wiring are available as options. Refer to special wiring specifications (options) below.

**Lead wire colors for D-sub connector assemblies (AXT100-DS25-015, 030, 050)**

| Standard wiring         | Terminal no. | Lead wire color | Dot marking |
|-------------------------|--------------|-----------------|-------------|
| Station 1 { SOL.A } 1   | 1            | Black           | None        |
| Station 1 { SOL.B } 2   | 2            | Yellow          | Black       |
| Station 2 { SOL.A } 14  | 14           | Brown           | None        |
| Station 2 { SOL.B } 15  | 15           | Pink            | Black       |
| Station 3 { SOL.A } 3   | 3            | Red             | None        |
| Station 3 { SOL.B } 16  | 16           | Blue            | White       |
| Station 4 { SOL.A } 4   | 4            | Orange          | None        |
| Station 4 { SOL.B } 17  | 17           | Purple          | None        |
| Station 5 { SOL.A } 5   | 5            | Yellow          | None        |
| Station 5 { SOL.B } 18  | 18           | Gray            | None        |
| Station 6 { SOL.A } 6   | 6            | Pink            | None        |
| Station 6 { SOL.B } 19  | 19           | Orange          | Black       |
| Station 7 { SOL.A } 7   | 7            | Blue            | None        |
| Station 7 { SOL.B } 20  | 20           | Red             | White       |
| Station 8 { SOL.A } 8   | 8            | Purple          | White       |
| Station 8 { SOL.B } 21  | 21           | Brown           | White       |
| Station 9 { SOL.A } 9   | 9            | Gray            | Black       |
| Station 9 { SOL.B } 22  | 22           | Pink            | Red         |
| Station 10 { SOL.A } 10 | 10           | White           | Black       |
| Station 10 { SOL.B } 23 | 23           | Gray            | Red         |
| Station 11 { SOL.A } 11 | 11           | White           | Red         |
| Station 11 { SOL.B } 24 | 24           | Black           | White       |
| Station 12 { SOL.A } 12 | 12           | Yellow          | Red         |
| Station 12 { SOL.B } 25 | 25           | White           | None        |
| COM.                    | 13           | Orange          | Red         |

### Special Wiring Specifications (Options)

(For 25P)

Mixed single and double wiring are available as options. The maximum number of manifold stations is determined by the number of solenoids. Count one point for a single solenoid type and two points for a double solenoid type. The total number of solenoids (points) must not exceed 24.

### Cable Assembly

**AXT100-DS25-030**  
015  
050

(D-sub connector cable assemblies can be ordered with manifolds.)  
(Refer to manifold ordering.)

**Lead wire colors for D-sub connector cable assembly terminal numbers**

| Terminal no. | Lead wire color | Dot marking |
|--------------|-----------------|-------------|
| 1            | Black           | None        |
| 2            | Brown           | None        |
| 3            | Red             | None        |
| 4            | Orange          | None        |
| 5            | Yellow          | None        |
| 6            | Pink            | None        |
| 7            | Blue            | None        |
| 8            | Purple          | White       |
| 9            | Gray            | Black       |
| 10           | White           | Black       |
| 11           | White           | Red         |
| 12           | Yellow          | Red         |
| 13           | Orange          | Red         |
| 14           | Yellow          | Black       |
| 15           | Pink            | Black       |
| 16           | Blue            | White       |
| 17           | Purple          | None        |
| 18           | Gray            | None        |
| 19           | Orange          | Black       |
| 20           | Red             | White       |
| 21           | Brown           | White       |
| 22           | Pink            | Red         |
| 23           | Gray            | Red         |
| 24           | Black           | White       |
| 25           | White           | None        |

**D-sub connector cable assemblies**

| Cable length [L] | Part no.        | Note                     |
|------------------|-----------------|--------------------------|
| 1.5 m            | AXT100-DS25-015 | Cable 0.3 mm² x 25 cores |
| 3 m              | AXT100-DS25-030 |                          |
| 5 m              | AXT100-DS25-050 |                          |

- \* When using a standard commercial connector, use a type 25P female connector conforming to MIL-C-24308.
- \* Cannot be used for transfer wiring.
- \* Lengths other than the above is also available. Please contact SMC for details.

**Electrical characteristics**

| Item  | Characteristic |
|---|----------------|
| Conductor resistance $\Omega/\text{km}$ , 20°C          | 65 or less     |
| Voltage limit V, 1 minute, AC                           | 1000           |
| Insulation resistance $\text{M}\Omega/\text{km}$ , 20°C | 5 or more      |

(Note) The minimum bending radius for D-sub connector cables is 20 mm.

**Connector Manufacturers Example**

- Fujitsu, Limited
- Japan Aviation Electronics Industry, Limited
- J.S.T. Mfg. Co., Ltd.
- HIROSE ELECTRIC CO., LTD.

# F VQC5000

Kit (D-sub connector kit) IP40 compliant

VV5QC51

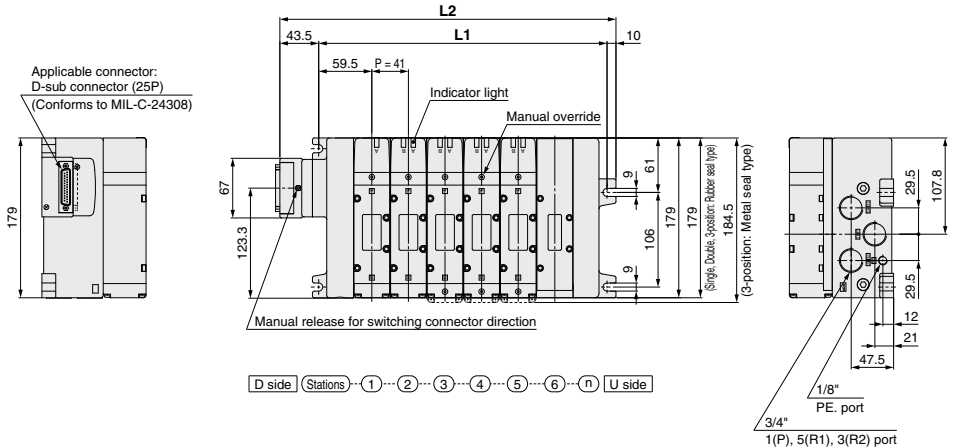

- SV
- SYJ
- SZ
- VF
- VP4
- VQ 1/2
- VQ 4/5
- VQC 1/2
- VQC 4/5
- VQZ
- SQ
- VFS
- VFR
- VQ7

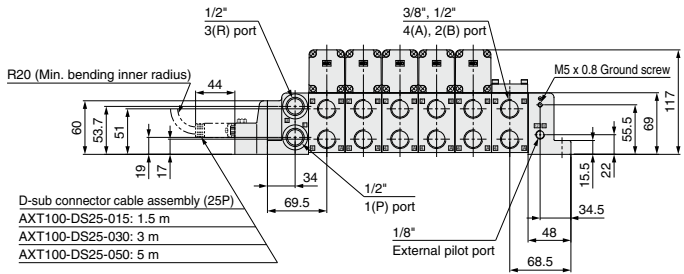

**Bottom ported**

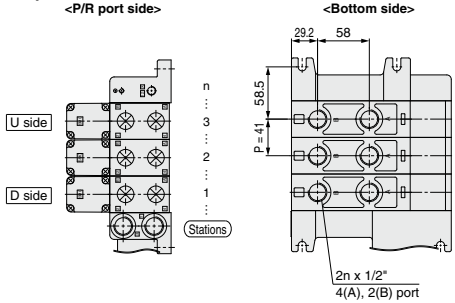

\* Other dimensions are the same as the side ported type.

**Dimensions**

Formula:  $L1 = 41n + 77$ ,  $L2 = 41n + 130.5$  n: Stations (Maximum 12 stations)

| n  | 1     | 2     | 3     | 4     | 5     | 6     | 7     | 8     | 9     | 10    | 11    | 12    |
|----|-------|-------|-------|-------|-------|-------|-------|-------|-------|-------|-------|-------|
| L1 | 118   | 159   | 200   | 241   | 282   | 323   | 364   | 405   | 446   | 487   | 528   | 569   |
| L2 | 171.5 | 212.5 | 253.5 | 294.5 | 335.5 | 376.5 | 417.5 | 458.5 | 499.5 | 540.5 | 581.5 | 622.5 |

# VQC5000 Series

## **P** VQC5000 Kit (Flat ribbon cable kit) IP40 compliant

- Using our flat ribbon cable for electrical connections greatly reduces labor, while it also minimizes wiring and saves space.
- We use flat ribbon cables whose connectors (26P and 20P) conform to MIL standards, and are therefore widely compatible with many standard commercial models.
- Top or side entry for the connector can be changed freely, allowing for changes even after mounting, to meet any changing needs for space.

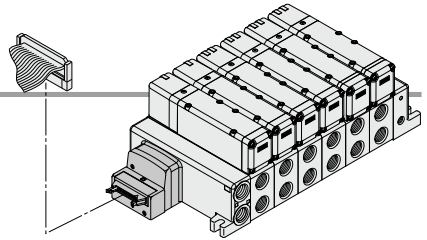

### Electrical Wiring Specifications

#### Flat ribbon cable connector

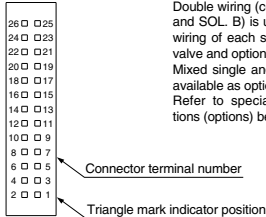

Double wiring (connected to SOL. A and SOL. B) is used for the internal wiring of each station regardless of valve and option types. Mixed single and double wiring are available as options. Refer to special wiring specifications (options) below.

<26P>

<20P>

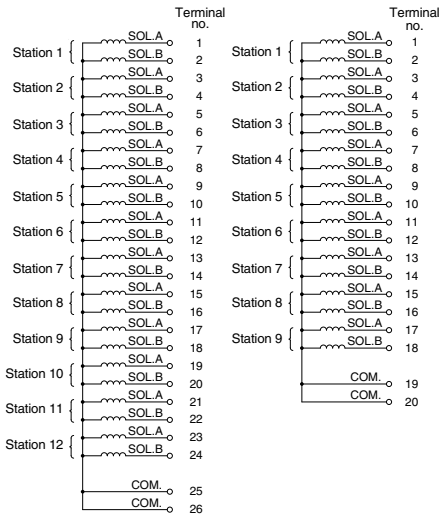

### Cable Assembly

AXT100-FC  $\frac{20}{26} - \frac{1}{2}$  3

(Type 26P flat ribbon cable connector assemblies can be ordered with manifolds. Refer to manifold ordering.)

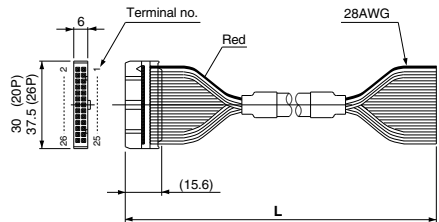

#### Flat ribbon cable connector assemblies

| Cable length [L] | Part no.      |               |
|------------------|---------------|---------------|
|                  | 26P           | 20P           |
| 1.5 m            | AXT100-FC26-1 | AXT100-FC20-1 |
| 3 m              | AXT100-FC26-2 | AXT100-FC20-2 |
| 5 m              | AXT100-FC26-3 | AXT100-FC20-3 |

- \* When using a standard commercial connector, use a type 26P connector conforming to MIL-C-83503 or a type 20P with strain relief.
- \* Cannot be used for transfer wiring.
- \* Lengths other than the above is also available. Please contact SMC for details.

#### Connector Manufacturers Example

- HIROSE ELECTRIC CO., LTD.
- 3M Japan Limited
- Fujitsu, Limited
- Japan Aviation Electronics Industry, Limited
- J.S.T. Mfg. Co., Ltd.
- Oki Electric Cable Co., Ltd.

### Special Wiring Specifications (Option)

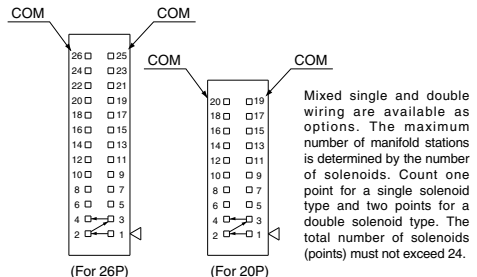

# P VQC5000

Kit (Flat ribbon cable kit) IP40 compliant

VV5QC51

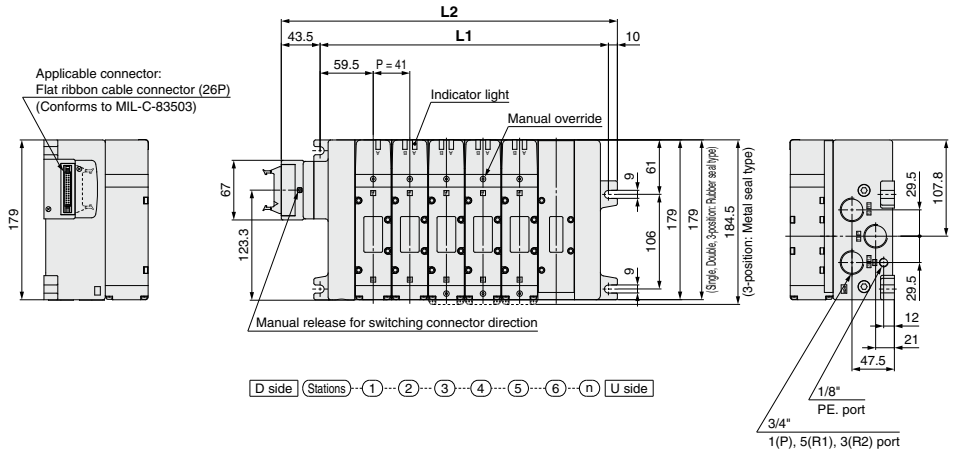

- SV
- SYJ
- SZ
- VF
- VP4
- VQ 1/2
- VQ 4/5
- VQC 1/2
- VQC 4/5
- VQZ
- SQ
- VFS
- VFR
- VQ7

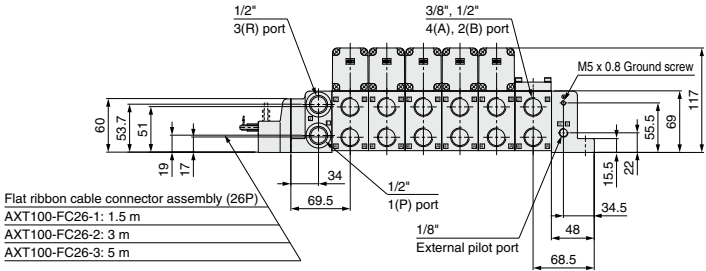

**Bottom ported**

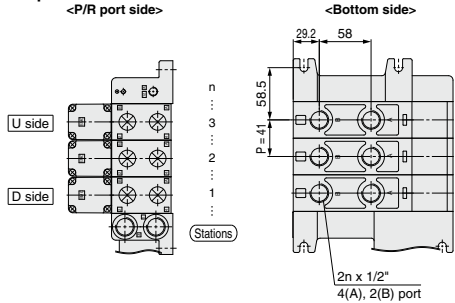

\* Other dimensions are the same as the side ported type.

**Dimensions**

Formula: L1 = 41n + 77, L2 = 41n + 130.5 n: Stations (Maximum 12 stations)

| L  | n | 1     | 2     | 3     | 4     | 5     | 6     | 7     | 8     | 9     | 10    | 11    | 12    |
|----|---|-------|-------|-------|-------|-------|-------|-------|-------|-------|-------|-------|-------|
| L1 |   | 118   | 159   | 200   | 241   | 282   | 323   | 364   | 405   | 446   | 487   | 528   | 569   |
| L2 |   | 171.5 | 212.5 | 253.5 | 294.5 | 335.5 | 376.5 | 417.5 | 458.5 | 499.5 | 540.5 | 581.5 | 622.5 |

# VQC5000 Series

## T VQC5000 Kit (Terminal block box kit) IP67 compliant

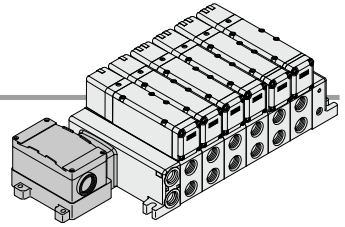

- This kit has a small terminal block inside a junction box. The provision of a G3/4 electrical entry allows connection of conduit fittings.

### Terminal Block Connection

#### Step 1. How to remove terminal block cover

Loosen the 4 mounting screws (M4) and remove the terminal block cover.

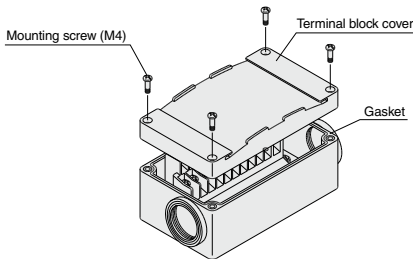

#### Step 3. How to replace the terminal block cover

Securely tighten the screws to the torque shown in the table below, after confirming that the gasket is installed correctly.

| Proper tightening torque [N·m] |
|--------------------------------|
| 0.7 to 1.2                     |

- Applicable crimped terminal: 1.25-3S, 1.25Y-3, 1.25Y-3N, 1.25Y-3.5
- Name plate: VVQ5000-N-T
- Drip proof plug assembly (for G3/4): AXT100-B06A

#### Step 2. The diagram below shows the terminal block wiring.

**All stations are provided with double wiring regardless of the valves which are mounted.**

Connect each wire to the power supply side, according to the markings provided inside the terminal block.

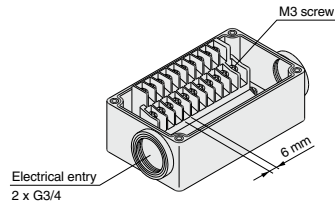

### Electrical Wiring Specifications (Conforms to IP67)

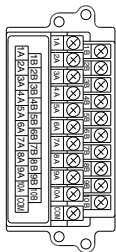

The internal wiring is double (connected to SOL. A and SOL. B) for all stations regardless of the type of valve or options. Mixed single and double wiring are available as options.

#### Standard wiring

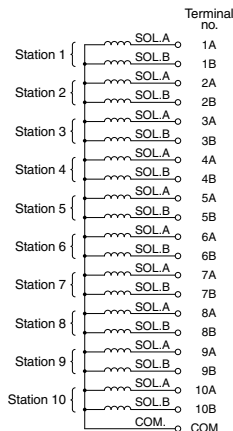

#### Special Wiring Specifications (Option)

Mixed single and double wiring are available as options. The maximum number of manifold stations is determined by the number of solenoids. Count one point for a single solenoid type and two points for a double solenoid type. The total number of solenoids (points) must not exceed 20.

##### 1. How to Order

Indicate option symbol "K" in the manifold part number and be sure to specify station positions for single or double wiring on the manifold specification sheet.

##### 2. Wiring specifications

Connector terminal numbers are connected from solenoid station 1 on the A side in the order indicated by the arrows without skipping any terminal numbers.

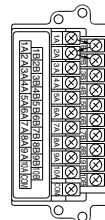

# T VQC5000

Kit (Terminal block box) IP67 compliant

VV5QC51

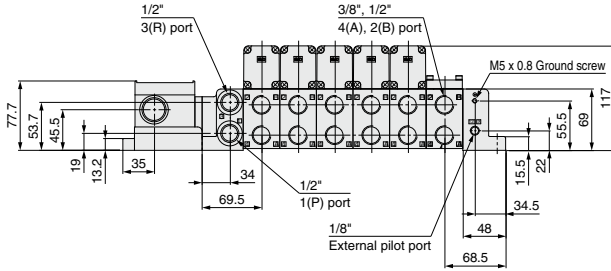
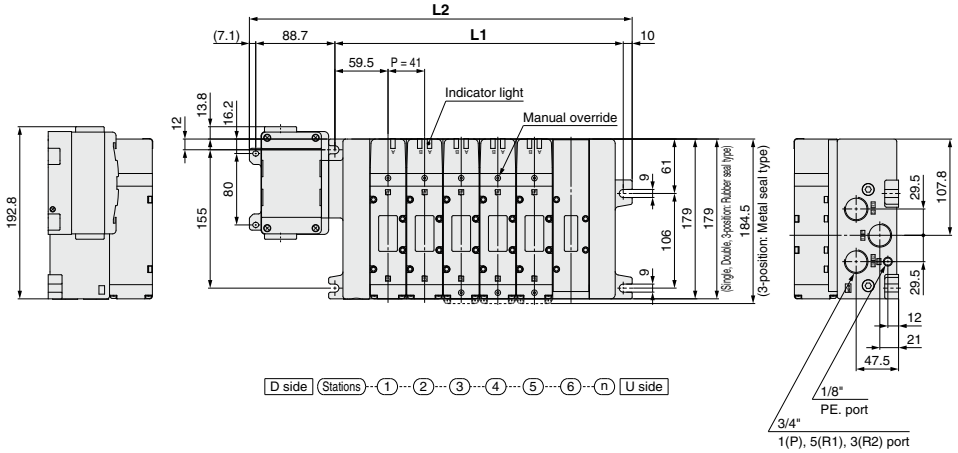

**Bottom ported**

<P/R port side>

<Bottom side>

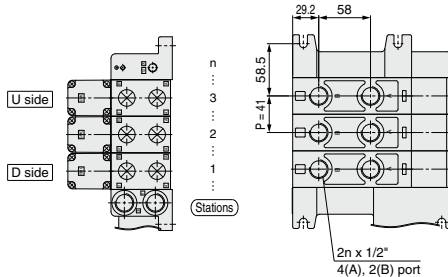

\* Other dimensions are the same as the side ported type.

**Dimensions**

Formula: L1 = 41n + 77, L2 = 41n + 182.8 n: Stations (Maximum 12 stations)

| L  | n | 1     | 2     | 3     | 4     | 5     | 6     | 7     | 8     | 9     | 10    | 11    | 12    |
|----|---|-------|-------|-------|-------|-------|-------|-------|-------|-------|-------|-------|-------|
| L1 |   | 118   | 159   | 200   | 241   | 282   | 323   | 364   | 405   | 446   | 487   | 528   | 569   |
| L2 |   | 223.8 | 264.8 | 305.8 | 346.8 | 387.8 | 428.8 | 469.8 | 510.8 | 551.8 | 592.8 | 633.8 | 674.8 |

- SV
- SYJ
- SZ
- VF
- VP4
- VQ 1/2
- VQ 4/5
- VQC 1/2
- VQC 4/5**
- VQZ
- SQ
- VFS
- VFR
- VQ7

# VQC5000 Series

## **L** VQC5000 Kit (Lead wire kit) IP67 compliant

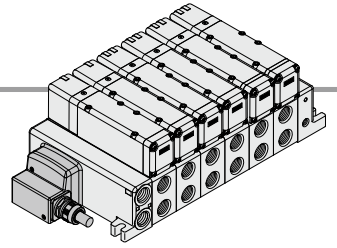

- Direct electrical entry type
- IP67 enclosure is available with use of cables with sheath and waterproof connectors.

### Electrical Wiring Specifications

#### Lead wire specifications

Lead wire

0.3 mm<sup>2</sup> x 25 cores

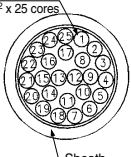

As the standard electrical wiring specification used is for 12 stations or less, double wiring (connected to SOL. A and SOL. B) is used for the internal wiring of each station regardless of valve and option types.

Mixed single and double wiring are available as options.

Refer to special wiring specifications (options) below.

#### Lead wire length

VV5QC51-08 C12 LD **0**

Lead wire length

|   |       |
|---|-------|
| 0 | 0.6 m |
| 1 | 1.5 m |
| 2 | 3.0 m |

#### Electrical characteristics

| Item                                  | Characteristic |
|---------------------------------------|----------------|
| Conductor resistance<br>Ω/km, 20°C    | 65 or less     |
| Withstand pressure<br>V, 1 minute, AC | 1000           |
| Insulation resistance<br>MΩ/km, 20°C  | 5 or more      |

Note) Cannot be used for transfer wiring.  
The minimum bending radius for cables is 20 mm.

|            | Terminal no. | Lead wire color | Dot marking |
|------------|--------------|-----------------|-------------|
| Station 1  | SOL.A        | 1 Black         | None        |
|            | SOL.B        | 14 Yellow       | Black       |
| Station 2  | SOL.A        | 2 Brown         | None        |
|            | SOL.B        | 15 Pink         | Black       |
| Station 3  | SOL.A        | 3 Red           | None        |
|            | SOL.B        | 16 Blue         | White       |
| Station 4  | SOL.A        | 4 Orange        | None        |
|            | SOL.B        | 17 Purple       | None        |
| Station 5  | SOL.A        | 5 Yellow        | None        |
|            | SOL.B        | 18 Gray         | None        |
| Station 6  | SOL.A        | 6 Pink          | None        |
|            | SOL.B        | 19 Orange       | Black       |
| Station 7  | SOL.A        | 7 Blue          | None        |
|            | SOL.B        | 20 Red          | White       |
| Station 8  | SOL.A        | 8 Purple        | White       |
|            | SOL.B        | 21 Brown        | White       |
| Station 9  | SOL.A        | 9 Gray          | Black       |
|            | SOL.B        | 22 Pink         | Red         |
| Station 10 | SOL.A        | 10 White        | Black       |
|            | SOL.B        | 23 Gray         | Red         |
| Station 11 | SOL.A        | 11 White        | Red         |
|            | SOL.B        | 24 Black        | White       |
| Station 12 | SOL.A        | 12 Yellow       | Red         |
|            | SOL.B        | 25 White        | None        |
|            | COM          | 13 Orange       | Red         |

### Special Wiring Specifications (Option)

Mixed single and double wiring are available as options. The maximum number of manifold stations is determined by the number of solenoids. Count one point for a single solenoid type and two points for a double solenoid type. The total number of solenoids (points) must not exceed 24.



VQC5000

Kit (Lead wire kit) IP67 compliant

VV5QC51

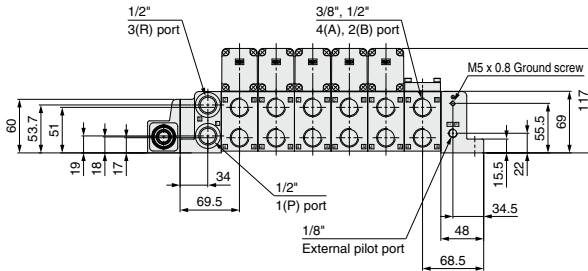
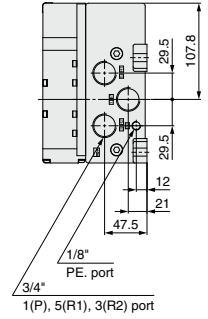
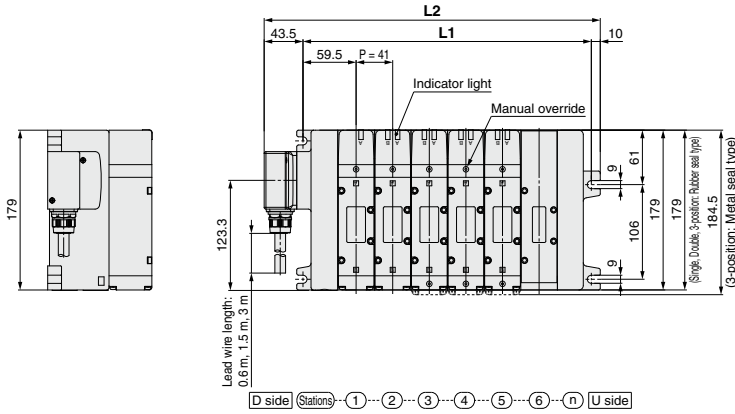

Bottom ported

<P/R port side>

<Bottom side>

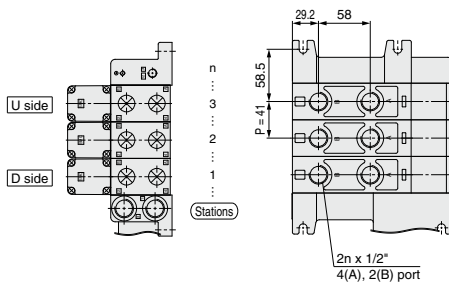

\* Other dimensions are the same as the side ported type.

Dimensions

Formula: L1 = 41n + 77, L2 = 41n + 130.5 n: Stations (Maximum 12 stations)

| L  | n | 1     | 2     | 3     | 4     | 5     | 6     | 7     | 8     | 9     | 10    | 11    | 12    |
|----|---|-------|-------|-------|-------|-------|-------|-------|-------|-------|-------|-------|-------|
| L1 |   | 118   | 159   | 200   | 241   | 282   | 323   | 364   | 405   | 446   | 487   | 528   | 569   |
| L2 |   | 171.5 | 212.5 | 253.5 | 294.5 | 335.5 | 376.5 | 417.5 | 458.5 | 499.5 | 540.5 | 581.5 | 622.5 |

- SV
- SYJ
- SZ
- VF
- VP4
- VQ 1/2
- VQ 4/5
- VQC 1/2
- VQC 4/5
- VQZ
- SQ
- VFS
- VFR
- VQ7

# VQC5000 Series

## M VQC5000 Kit (Circular connector kit) IP67 compliant

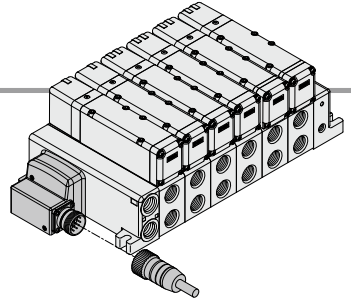

- Use of circular connectors helps streamline wiring procedure to save labor.
- IP67 enclosure is available with use of waterproof multiple connectors.

### Electrical Wiring Specifications

#### Multiple connector

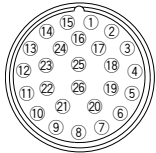

Double wiring (connected to SOL.A and SOL.B) is used for the internal wiring of each station regardless of valve and option types. Mixed single and double wiring are available as options. Refer to special wiring specifications (options) below.

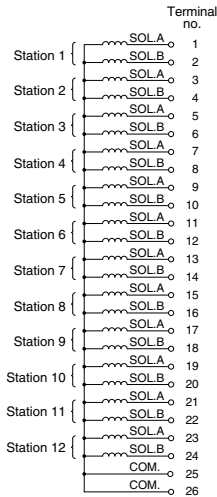

### Special Wiring Specifications (Option)

Mixed single and double wiring are available as options. The maximum number of manifold stations is determined by the number of solenoids. Count one point for a single solenoid type and two points for a double solenoid type. The total number of solenoids (points) must not exceed 24.

### Cable Assembly

**AXT100-MC26-030**  
015  
050

(Type 26P circular connector cable assemblies can be ordered with manifolds. Refer to manifolds ordering.)

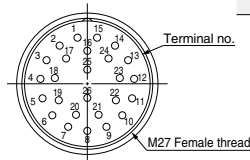
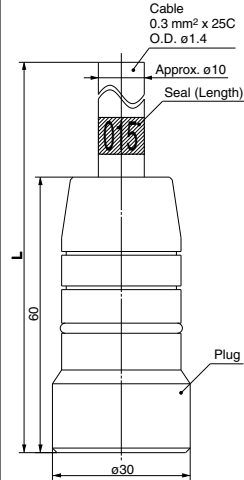

#### Lead wire colors for circular connector cable assembly terminal numbers

| Terminal no. | Lead wire color | Dot marking |
|--------------|-----------------|-------------|
| 1            | Black           | None        |
| 2            | Brown           | None        |
| 3            | Red             | None        |
| 4            | Orange          | None        |
| 5            | Yellow          | None        |
| 6            | Pink            | None        |
| 7            | Blue            | None        |
| 8            | Purple          | White       |
| 9            | Gray            | Black       |
| 10           | White           | Black       |
| 11           | White           | Red         |
| 12           | Yellow          | Red         |
| 13           | Orange          | Red         |
| 14           | Yellow          | Black       |
| 15           | Pink            | Black       |
| 16           | Blue            | White       |
| 17           | Purple          | None        |
| 18           | Gray            | None        |
| 19           | Orange          | Black       |
| 20           | Red             | White       |
| 21           | Brown           | White       |
| 22           | Pink            | Red         |
| 23           | Gray            | Red         |
| 24           | Black           | White       |
| 25           | White           | None        |
| 26           | White           | None        |

#### Electric characteristics

| Item                                 | Property   |
|--------------------------------------|------------|
| Conductor resistance<br>Ω/km, 20°C   | 65 or less |
| Voltage limit<br>V, 1 minute, AC     | 1000       |
| Insulation resistance<br>MΩ/km, 20°C | 5 or more  |

(Note) The minimum bending radius of the multiple connector cable is 20 mm.

#### Circular connector cable assemblies

| Cable length [L] | Assembly part no. |
|------------------|-------------------|
|                  | 26P               |
| 1.5 m            | AXT100-MC26-015   |
| 3 m              | AXT100-MC26-030   |
| 5 m              | AXT100-MC26-050   |

- \* Cannot be used for transfer wiring.
- \* Lengths other than the above is also available. Please contact SMC for details.



VQC5000

Kit (Circular connector kit) IP67 compliant

VV5QC51

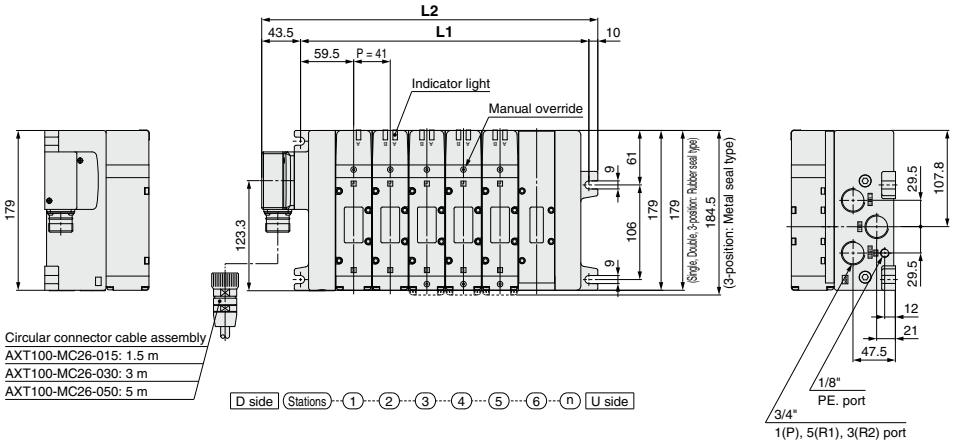

- SV
- SYJ
- SZ
- VF
- VP4
- VQ 1/2
- VQ 4/5
- VQC 1/2
- VQC 4/5
- VQZ
- SQ
- VFS
- VFR
- VQ7

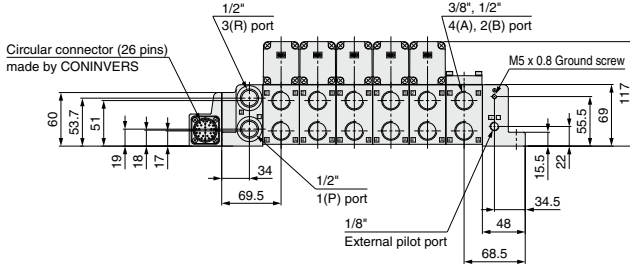

Bottom ported

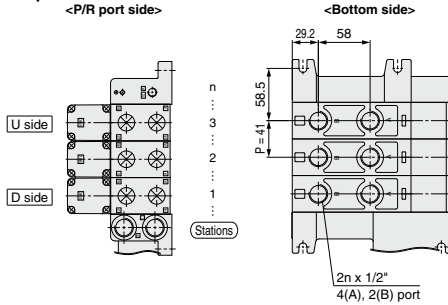

\* Other dimensions are the same as the side ported type.

Dimensions

Formula: L1 = 41n + 77, L2 = 41n + 130.5 n: Stations (Maximum 12 stations)

| L  | n | 1     | 2     | 3     | 4     | 5     | 6     | 7     | 8     | 9     | 10    | 11    | 12    |
|----|---|-------|-------|-------|-------|-------|-------|-------|-------|-------|-------|-------|-------|
| L1 |   | 118   | 159   | 200   | 241   | 282   | 323   | 364   | 405   | 446   | 487   | 528   | 569   |
| L2 |   | 171.5 | 212.5 | 253.5 | 294.5 | 335.5 | 376.5 | 417.5 | 458.5 | 499.5 | 540.5 | 581.5 | 622.5 |



# VQC5000 Series Construction

## Plug-in Unit

### Metal seal type

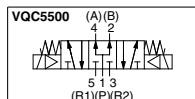
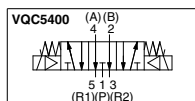
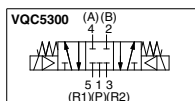
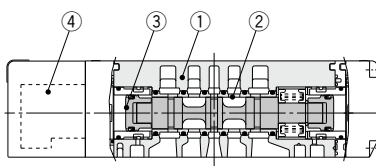
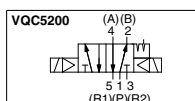
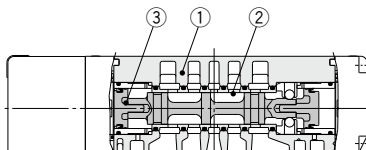
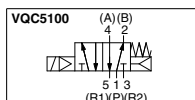
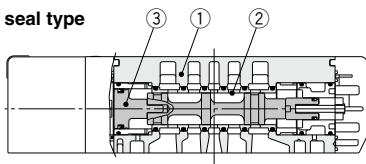

### Rubber seal type

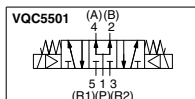
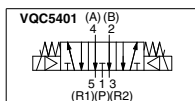
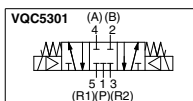
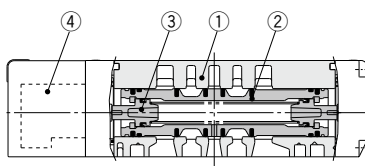
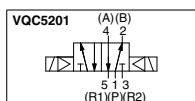
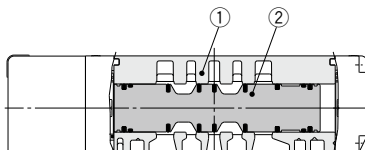
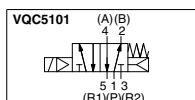
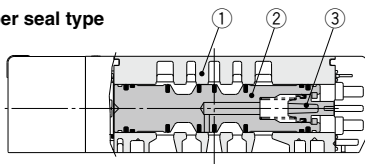

### Component Parts

| No. | Description  | Material            | Note |
|-----|--------------|---------------------|------|
| 1   | Body         | Aluminum die-casted |      |
| 2   | Spool/Sleeve | Stainless steel     |      |
| 3   | Piston       | Resin               |      |

### Replacement Parts

|   |                      |  |  |
|---|----------------------|--|--|
| 4 | Pilot valve assembly | V118 □ □ □ A<br>□ □ □ B<br>□ □ □ E                                 | <input type="checkbox"/> Coil rated voltage<br>Example) 24 VDC: 5<br>A: With light (For A side)<br>B: With light (For B side)<br>E: Without light<br>(A/B side common) |
|   |                      | • Coil type<br>Nil Standard (0.95 W)<br>Y Low wattage type (0.4 W) |  |

### Component Parts

| No. | Description | Material            | Note |
|-----|-------------|---------------------|------|
| 1   | Body        | Aluminum die-casted |      |
| 2   | Spool valve | Aluminum, HNBR      |      |
| 3   | Piston      | Resin               |      |

### Replacement Parts

|   |                      |  |  |
|---|----------------------|--|--|
| 4 | Pilot valve assembly | V118 □ □ □ A<br>□ □ □ B<br>□ □ □ E                                 | <input type="checkbox"/> Coil rated voltage<br>Example) 24 VDC: 5<br>A: With light (For A side)<br>B: With light (For B side)<br>E: Without light<br>(A/B side common) |
|   |                      | • Coil type<br>Nil Standard (0.95 W)<br>Y Low wattage type (0.4 W) |  |

# VQC5000 Series

# Exploded View of Manifold

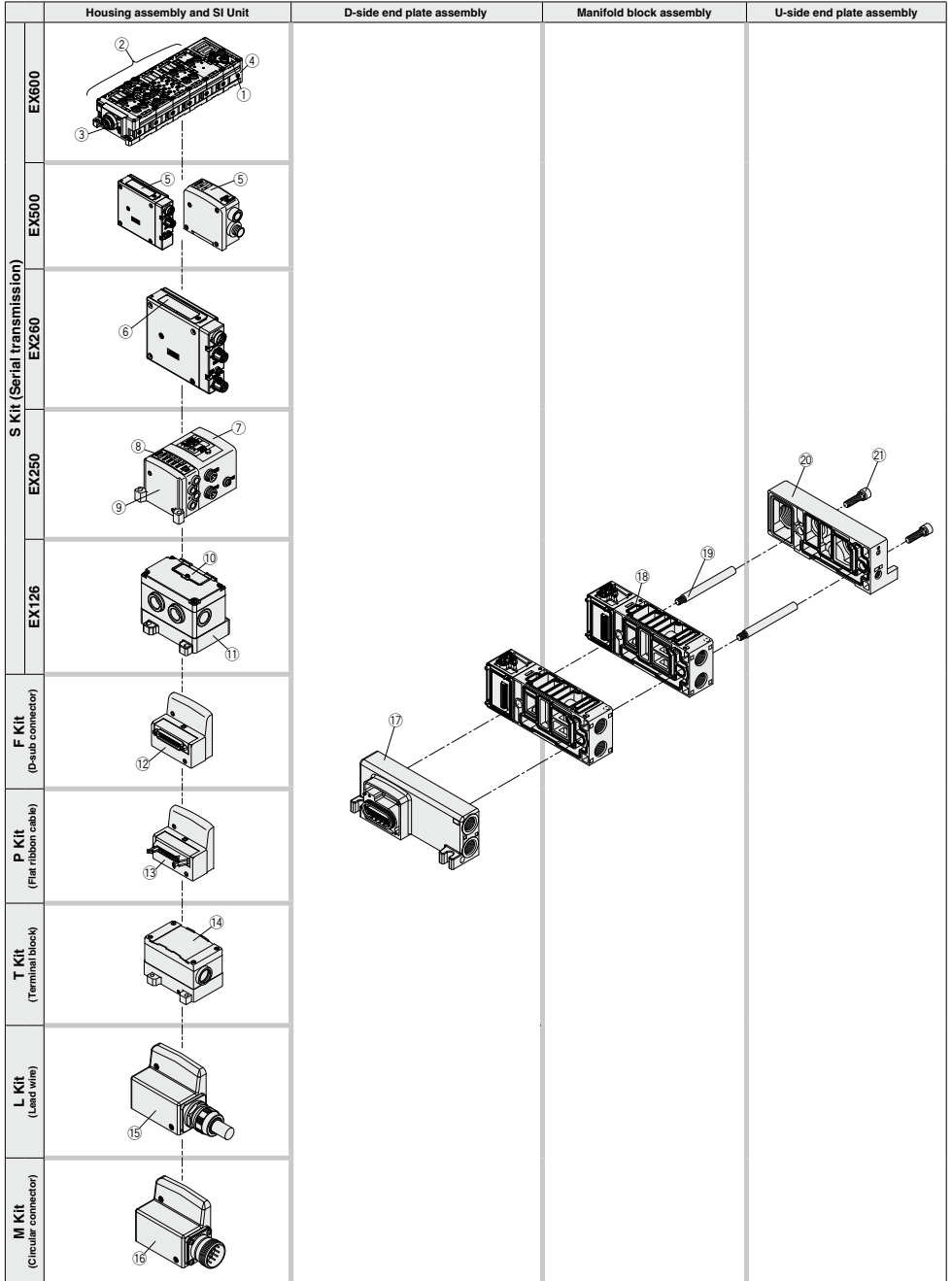

SV

SYJ

SZ

VF

VP4

VQ

1/2

VQ

4/5

VQC

1/2

VQC

4/5

VQZ

SQ

VFS

VFR

VQ7

# VQC5000 Series

## Manifold Assembly Part No.

### Housing Assembly and SI Unit/Input Block

| No.                      | Description               | Part no.  | Note   |
|--------------------------|---------------------------|---|--|
| ①                        | SI Unit                   | EX600-SDN1A   | DeviceNet™, Negative common (PNP)  |
|                          |                           | EX600-SDN2A   | DeviceNet™, Positive common (NPN)  |
|                          |                           | EX600-SMJ1  | CC-Link, Negative common (PNP)   |
|                          |                           | EX600-SMJ2  | CC-Link, Positive common (NPN)   |
|                          |                           | EX600-SPR1A   | PROFIBUS DP, Negative common (PNP)   |
|                          |                           | EX600-SPR2A   | PROFIBUS DP, Positive common (NPN)   |
|                          |                           | EX600-SEN1  | EtherNet/IP™ (1 port), Negative common (PNP)   |
|                          |                           | EX600-SEN2  | EtherNet/IP™ (1 port), Positive common (NPN)   |
|                          |                           | EX600-SEN3  | EtherNet/IP™ (2 port), Negative common (PNP)   |
|                          |                           | EX600-SEN4  | EtherNet/IP™ (2 port), Positive common (NPN)   |
|                          |                           | EX600-SPN1  | PROFINET, Negative common (PNP)  |
|                          |                           | EX600-SPN2  | PROFINET, Positive common (NPN)  |
|                          |                           | EX600-SEC1  | EtherCAT, Negative common (PNP)  |
|                          |                           | EX600-SEC2  | EtherCAT, Positive common (NPN)  |
|                          |                           | EX600-WEN1 <sup>Note)</sup>   | Wireless base module EtherNet/IP™ Negative common (PNP)                              |
|                          |                           | EX600-WEN2 <sup>Note)</sup>   | Wireless base module EtherNet/IP™ Positive common (NPN)                              |
|                          |                           | EX600-WPN1 <sup>Note)</sup>   | Wireless base module PROFINET Negative common (PNP)                                  |
|                          |                           | EX600-WPN2 <sup>Note)</sup>   | Wireless base module PROFINET Positive common (NPN)                                  |
|                          |                           | EX600-WSV1 <sup>Note)</sup>   | Wireless remote module Negative common (PNP)   |
|                          |                           | EX600-WSV2 <sup>Note)</sup>   | Wireless remote module Positive common (NPN)   |
| ②                        | Digital Input Unit        | EX600-DXNB  | NPN input, M12 connector, 5 pins (4 pcs.), 8 inputs                                  |
|                          |                           | EX600-DXPB  | PNP input, M12 connector, 5 pins (4 pcs.), 8 inputs                                  |
|                          |                           | EX600-DXNC  | NPN input, M8 connector, 3 pins (8 pcs.), 8 inputs                                   |
|                          |                           | EX600-DXNC1   | NPN input, M8 connector, 3 pins (8 pcs.), 8 inputs, with open circuit detection      |
|                          |                           | EX600-DXPC  | PNP input, M8 connector, 3 pins (8 pcs.), 8 inputs                                   |
|                          |                           | EX600-DXPC1   | PNP input, M8 connector, 3 pins (8 pcs.), 8 inputs, with open circuit detection      |
|                          |                           | EX600-DXND  | NPN input, M12 connector, 5 pins (8 pcs.), 16 inputs                                 |
|                          |                           | EX600-DXPD  | PNP input, M12 connector, 5 pins (8 pcs.), 16 inputs                                 |
|                          |                           | EX600-DXNE  | NPN input, D-sub connector, 25 pins, 16 inputs                                       |
|                          |                           | EX600-DXPE  | PNP input, D-sub connector, 25 pins, 16 inputs                                       |
|                          | EX600-DXNF                | NPN input, Spring type terminal box, 32 pins, 16 inputs               |  |
|                          | EX600-DXPF                | PNP input, Spring type terminal box, 32 pins, 16 inputs               |  |
|                          | Digital Output Unit       | EX600-DYNB  | NPN output, M12 connector, 5 pins (4 pcs.), 8 outputs                                |
|                          |                           | EX600-DYPB  | PNP output, M12 connector, 5 pins (4 pcs.), 8 outputs                                |
|                          |                           | EX600-DYNE  | NPN output, D-sub connector, 25 pins, 16 outputs                                     |
|                          |                           | EX600-DYPE  | PNP output, D-sub connector, 25 pins, 16 outputs                                     |
|                          |                           | EX600-DYNF  | NPN output, Spring type terminal box, 32 pins, 16 outputs                            |
|                          |                           | EX600-DYPF  | PNP output, Spring type terminal box, 32 pins, 16 outputs                            |
|                          | Digital Input/Output Unit | EX600-DMNE  | NPN input/output, D-sub connector, 25 pins, 8 inputs/outputs                         |
|                          |                           | EX600-DMPE  | PNP input/output, D-sub connector, 25 pins, 8 inputs/outputs                         |
| EX600-DMNF               |                           | NPN input/output, Spring type terminal box, 32 pins, 8 inputs/outputs |  |
|                          | EX600-DMPF                | PNP input/output, Spring type terminal box, 32 pins, 8 inputs/outputs |  |
| Analog Input Unit        |                           | EX600-AXA   | M12 connector, 5 pins (2 pcs.), 2-channel input                                      |
| Analog Output Unit       |                           | EX600-AYA   | M12 connector, 5 pins (2 pcs.), 2-channel output                                     |
| Analog Input/Output Unit |                           | EX600-AMB   | M12 connector, 5 pins (4 pcs.), 2-channel input/output                               |
| ③                        | End plate                 | EX600-ED2   | M12 power supply connector, B-coded  |
|                          |                           | EX600-ED3   | 7/8 inch power supply connector  |
|                          |                           | EX600-ED4   | M12 power supply connector IN/OUT, A-coded, Pin arrangement 1                        |
|                          |                           | EX600-ED5   | M12 power supply connector IN/OUT, A-coded, Pin arrangement 2                        |
| ④                        | Valve plate               | EX600-ZMV1  | Enclosed parts: Round head screws (M4 x 6) 2 pcs., Round head screws (M3 x 8) 4 pcs. |
| ⑤                        | SI Unit                   | EX500-S103  | EtherNet/IP™, PROFINET, Negative common (PNP)  |
|                          |                           | EX500-Q001  | DeviceNet™, PROFIBUS DP, EtherNet/IP™, Positive common (NPN)                         |
|                          |                           | EX500-Q101  | DeviceNet™, PROFIBUS DP, EtherNet/IP™, Negative common (PNP)                         |

Note) The wireless system is suitable for use only in a country where it is in accordance with the Radio Act and regulations of that country.

**Manifold Assembly Part No.**

**Housing Assembly and SI Unit/Input Block**

| No.         | Description   | Part no.         | Note   |
|-------------|---|------------------|--|
| ⑥           | SI Unit   | EX260-SDN1       | DeviceNet™, M12 connector, 32 outputs, Negative common (PNP)         |
|             |   | EX260-SDN2       | DeviceNet™, M12 connector, 32 outputs, Positive common (NPN)         |
|             |   | EX260-SDN3       | DeviceNet™, M12 connector, 16 outputs, Negative common (PNP)         |
|             |   | EX260-SDN4       | DeviceNet™, M12 connector, 16 outputs, Positive common (NPN)         |
|             |   | EX260-SRP1       | PROFIBUS DP, M12 connector, 32 outputs, Negative common (PNP)        |
|             |   | EX260-SRP2       | PROFIBUS DP, M12 connector, 32 outputs, Positive common (NPN)        |
|             |   | EX260-SRP3       | PROFIBUS DP, M12 connector, 16 outputs, Negative common (PNP)        |
|             |   | EX260-SRP4       | PROFIBUS DP, M12 connector, 16 outputs, Positive common (NPN)        |
|             |   | EX260-SRP5       | PROFIBUS DP, D-sub connector, 32 outputs, Negative common (PNP)      |
|             |   | EX260-SRP6       | PROFIBUS DP, D-sub connector, 32 outputs, Positive common (NPN)      |
|             |   | EX260-SRP7       | PROFIBUS DP, D-sub connector, 16 outputs, Negative common (PNP)      |
|             |   | EX260-SRP8       | PROFIBUS DP, D-sub connector, 16 outputs, Positive common (NPN)      |
|             |   | EX260-SMJ1       | CC-Link, M12 connector, 32 outputs, Negative common (PNP)            |
|             |   | EX260-SMJ2       | CC-Link, M12 connector, 32 outputs, Positive common (NPN)            |
|             |   | EX260-SMJ3       | CC-Link, M12 connector, 16 outputs, Negative common (PNP)            |
|             |   | EX260-SMJ4       | CC-Link, M12 connector, 16 outputs, Positive common (NPN)            |
|             |   | EX260-SEC1       | EtherCAT, M12 connector, 32 outputs, Negative common (PNP)           |
|             |   | EX260-SEC2       | EtherCAT, M12 connector, 32 outputs, Positive common (NPN)           |
|             |   | EX260-SEC3       | EtherCAT, M12 connector, 16 outputs, Negative common (PNP)           |
|             |   | EX260-SEC4       | EtherCAT, M12 connector, 16 outputs, Positive common (NPN)           |
|             |   | EX260-SPN1       | PROFINET, M12 connector, 32 outputs, Negative common (PNP)           |
|             |   | EX260-SPN2       | PROFINET, M12 connector, 32 outputs, Positive common (NPN)           |
|             |   | EX260-SPN3       | PROFINET, M12 connector, 16 outputs, Negative common (PNP)           |
|             |   | EX260-SPN4       | PROFINET, M12 connector, 16 outputs, Positive common (NPN)           |
|             |   | EX260-SEN1       | EtherNet/IP™, M12 connector, 32 outputs, Negative common (PNP)       |
|             |   | EX260-SEN2       | EtherNet/IP™, M12 connector, 32 outputs, Positive common (NPN)       |
|             |   | EX260-SEN3       | EtherNet/IP™, M12 connector, 16 outputs, Negative common (PNP)       |
|             |   | EX260-SEN4       | EtherNet/IP™, M12 connector, 16 outputs, Positive common (NPN)       |
|             |   | EX260-SPL1       | Ethernet POWERLINK, M12 connector, 32 outputs, Negative common (PNP) |
|             |   | EX260-SPL3       | Ethernet POWERLINK, M12 connector, 16 outputs, Negative common (PNP) |
|             |   | EX260-SIL1       | IO-Link, M12 connector, 32 outputs, Negative common (PNP)            |
|             |   | ⑦                | SI Unit  |
| EX250-SAS3  | AS-Interface, 8 in/8 out, 31 slave modes, 2 power supply systems, Negative common (PNP) |                  |  |
| EX250-SAS5  | AS-Interface, 4 in/4 out, 31 slave modes, 2 power supply systems, Negative common (PNP) |                  |  |
| EX250-SAS7  | AS-Interface, 8 in/8 out, 31 slave modes, 1 power supply system, Negative common (PNP)  |                  |  |
| EX250-SAS9  | AS-Interface, 4 in/4 out, 31 slave modes, 1 power supply system, Negative common (PNP)  |                  |  |
| EX250-SCA1A | CANopen, Negative common (PNP)  |                  |  |
| EX250-SDN1  | DeviceNet™, Negative common (PNP)   |                  |  |
| EX250-SEN1  | EtherNet/IP™, Negative common (PNP)   |                  |  |
| ⑧           | Input block   | EX250-IE1        | M12, 2 inputs  |
|             |   | EX250-IE2        | M12, 4 inputs  |
|             |   | EX250-IE3        | M8, 4 inputs   |
| ⑨           | End plate assembly  | EX250-EA1        | Direct mounting  |
|             |   | EX250-EA2        | DIN rail mounting  |
| ⑩           | SI Unit   | EX126D-SMJ1      | CC-Link, Positive common (NPN)                                       |
| ⑪           | Terminal block plate  | VVQC1000-74A-2   | For EX126 SI Unit mounting   |
| ⑫           | D-sub connector housing assembly  | VVQC1000-F25-1   | F kit, 25 pins   |
|             |   | VVQC1000-P26-1   | P kit, 26 pins   |
| ⑬           | Flat ribbon cable housing assembly  | VVQC1000-P20-1   | P kit, 20 pins   |
|             |   | VVQC1000-T0-1    | T kit  |
| ⑭           | Terminal block box housing assembly   | VVQC1000-L25-0-1 | L kit with 0.6 m lead wire   |
|             |   | VVQC1000-L25-1-1 | L kit with 1.5 m lead wire   |
|             |   | VVQC1000-L25-2-1 | L kit with 3.0 m lead wire   |
| ⑮           | Lead wire housing assembly  | VVQC1000-M26-1   | M kit, 26 pins   |

|         |
|---------|
| SV      |
| SYJ     |
| SZ      |
| VF      |
| VP4     |
| VQ 1/2  |
| VQ 4/5  |
| VQC 1/2 |
| VQC 4/5 |
| VQZ     |
| SQ      |
| VFS     |
| VFR     |
| VQ7     |

# VQC5000 Series

## Manifold Assembly Part No.

### D-side end plate assembly

⑰ D-side end plate assembly part no.

VVQC5000-3A-2

• Thread type

|     |      |
|-----|------|
| Nil | Rc   |
| F   | G    |
| T   | NPTF |
| N   | NPT  |

### U-side end plate assembly

⑱ U-side end plate assembly part no.

VVQ5000-2A-1  -L-W

• Thread type

|     |      |
|-----|------|
| Nil | Rc   |
| F   | G    |
| T   | NPTF |
| N   | NPT  |

### Manifold block assembly

⑱ Manifold block assembly part no.

VVQC5000-1  **A** -  **D** -  **C6**

• Type

**A** For 1 station

Note) Tie-rods (2 pcs.) for additional stations included.

• Wiring specifications

|                                   |               |
|-----------------------------------|---------------|
| <input type="checkbox"/> <b>D</b> | Double wiring |
| <input type="checkbox"/> <b>S</b> | Single wiring |

• Thread type (Thread port only)

|     |      |
|-----|------|
| Nil | Rc   |
| F   | G    |
| T   | NPTF |
| N   | NPT  |

• Port size

| Symbol                             | Port size          |
|------------------------------------|--------------------|
| <input type="checkbox"/> <b>03</b> | 3/8"               |
| <input type="checkbox"/> <b>04</b> | 1/2"               |
| <input type="checkbox"/> <b>B</b>  | 1/2" bottom ported |

⑲ Tie-rod assembly part no. (2 units)

VQC5000  VVQC5000-TR-

Note 1) Please order when reducing the number of manifold stations. When increasing the number of stations, additional orders are not required since they are included in the manifold block assembly.

Note 2) Number of stations, 02 to 16

**List of Valves, Options, and Mounting Bolts**

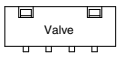
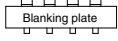
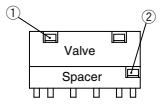
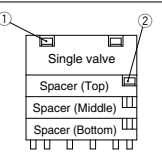
| Number of options   | Valve and options   | Bolt part no.   | Qty (pcs)  | Note   | Option mounting diagram  |
|---|---|---|--|--|--|
| 0   | Single valve  | AXT632-25-4 (M4 x 50)   | 4  |  |    |
|   | Blanking plate (VVQ5000-10A- $\frac{1}{2}$ )  | AXT632-25-8 (M4 x 17)   | 4  | For manifold   |    |
| 1   | Valve + Individual SUP spacer (VVQ5000-P- $\frac{1}{5}$ - $\frac{03}{03}$ )   | ① AXT632-25-5 (M4 x 82)<br>② AXT632-25-10 (M4 x 34)                   | 4<br>2   | For manifold   |    |
|   | Valve + Individual EXH spacer (VVQ5000-R- $\frac{1}{5}$ - $\frac{03}{03}$ )   | ① AXT632-25-5 (M4 x 82)<br>② AXT632-25-10 (M4 x 34)                   | 4<br>2   | For manifold   |  |
|   | Valve + Restrictor spacer (VVQ5000-20A- $\frac{1}{2}$ )   | ① AXT632-25-5 (M4 x 82)<br>② AXT632-25-10 (M4 x 34)                   | 4<br>2   | Not necessary when mounting the sub-plate.                                     |  |
|   | Valve + Release valve spacer (VVQ5000-24A- $\frac{1}{5}$ D)   | ① AXT632-25-5 (M4 x 82)<br>② AXT632-25-10 (M4 x 34)                   | 4<br>2   | For manifold   |  |
|   | Valve + Double check spacer with residual pressure exhaust (VVQ5000-25A- $\frac{1}{2}$ )  | ① AXT632-25-6 (M4 x 114)<br>② AXT632-66-1 (M4 x 64)                   | 4<br>2   | Not necessary when mounting the sub-plate.                                     |  |
|   | Valve + SUP stop valve spacer (VVQ5000-37A- $\frac{1}{2}$ )   | ① AXT632-25-5 (M4 x 82)<br>② AXT632-25-10 (M4 x 34)                   | 4<br>2   | Not necessary when mounting the sub-plate.                                     |  |
|   | Valve + Interface regulator (ARBQ5000-00- $\frac{A}{C}$ - $\frac{1}{2}$ )   | ① AXT632-25-6 (M4 x 114)<br>② AXT632-66-1 (M4 x 64)                   | 4<br>2   | Not necessary when mounting the sub-plate.                                     |  |
|   | Blanking plate + SUP stop valve (Top) (Bottom)  | ① AXT632-25-4 (M4 x 50)   | 4  | For manifold   |  |
|   |   | ② AXT632-25-10 (M4 x 34)  | 2  |  |  |
|   | 2   | Valve + Individual SUP + Individual EXH (Top) (Bottom) (Bottom) (Top) | ① AXT632-25-6 (M4 x 114)<br>② AXT632-25-11 (M4 x 66) | 4<br>2   |  |
| Valve + Restrictor + Individual SUP or Individual EXH (Top) (Bottom) (Top) (Bottom)             |   | ① AXT632-25-6 (M4 x 114)<br>② AXT632-25-11 (M4 x 66)                  | 4<br>2   | For manifold<br>* The individual EXH cannot be mounted on the top.             |  |
| Valve + SUP stop valve + Individual SUP, Individual EXH or Restrictor (Bottom)                  |   | ① AXT632-25-6 (M4 x 114)<br>② AXT632-25-11 (M4 x 66)                  | 4<br>2   | For manifold   |  |
| Valve + Double check spacer with residual pressure exhaust (Top) Individual EXH (Bottom)        |   | ① AXT632-25-7 (M4 x 146)<br>② AXT632-66-2 (M4 x 96)                   | 4<br>2   | For manifold   |  |
| Valve + Interface regulator + Double check spacer with residual pressure exhaust (Top) (Bottom) |   | ① AXT632-25-14 (M4 x 178)<br>② AXT632-66-3 (M4 x 128)                 | 4<br>2   | For manifold   |  |
| Valve + Interface regulator + Individual SUP, Individual EXH or Restrictor (Bottom)             |   | ① AXT632-25-7 (M4 x 146)<br>② AXT632-66-2 (M4 x 96)                   | 4<br>2   | For manifold<br>* The individual EXH and restrictor can be mounted on the top. |  |
| Blanking plate + SUP stop valve (Top) + Individual SUP (Bottom)                                 |   | ① AXT632-25-5 (M4 x 82)   | 4  | For manifold   |  |
|   |   | ② AXT632-25-11 (M4 x 66)  | 2  |  |  |
| 3   | Valve + SUP stop valve (Top) + Individual SUP (Middle, Bottom) + Individual EXH (Middle, Bottom)  | ① AXT632-25-7 (M4 x 146)<br>② AXT632-25-12 (M4 x 98)                  | 4<br>2   | For manifold   |  |
|   | Valve + Double check spacer with residual pressure exhaust (Top) + Individual SUP (Middle, Bottom) + Individual EXH (Middle, Bottom)  | ① AXT632-25-14 (M4 x 178)<br>② AXT632-66-3 (M4 x 128)                 | 4<br>2   | For manifold   |  |
|   | Valve + Spacer (Top): Interface regulator Spacer (Middle); "Individual SUP or Individual EXH"/"Restrictor" Spacer (Bottom); "Restrictor"/"Individual SUP or Individual EXH" | ① AXT632-25-14 (M4 x 178)<br>② AXT632-66-3 (M4 x 128)                 | 4<br>2   | For manifold<br>* The individual EXH and restrictor can be mounted on the top. |  |

Note) When the SUP stop valve and individual SUP are mounted, the stop valve is mounted on the top of the individual SUP.

- SV
- SYJ
- SZ
- VF
- VP4
- VQ 1/2
- VQ 4/5
- VQC 1/2
- VQC 4/5
- VQZ
- SQ
- VFS
- VFR
- VQ7



# VQC5000 Series Specific Product Precautions 1

Be sure to read this before handling the products.  
Refer to back page 50 for Safety Instructions and pages 3 to 9 for 3/4/5 Port Solenoid Valve Precautions.

## Continuous Duty

### ⚠ Warning

When the product is continuously energized for a long period of time (10 minutes or longer), select the low wattage type (DC specification). The AC type cannot be continuously energized for 10 minutes or longer. If anything is unclear, please contact SMC.

## Manual Override

### ⚠ Warning

Since connected equipment will operate when the manual override is activated, confirm that conditions are safe prior to activation.

#### ■ VQC5000

Push type (Tool required)

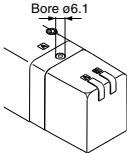

Push down the manual override button with a small screwdriver, etc., until it stops. The manual override will return when released.

Locking type (Tool required)

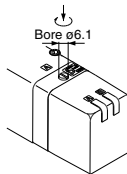

Push down the manual override button with a small flat head screwdriver until it stops, and turn it clockwise 90° to lock it. Turn it counterclockwise to release it.

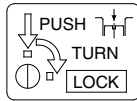

Locking type (Manual)

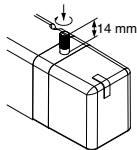

Push down the manual override button with a small flat head screwdriver or with your finger until it stops, and turn it clockwise 90° to lock it. Turn it counterclockwise to release it.

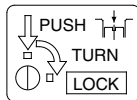

### ⚠ Caution

Do not apply excessive torque when turning the locking type manual override. (0.1 N·m or less)

## Valve Mounting

### ⚠ Caution

After confirming that the gasket is installed correctly, securely tighten the mounting screws according to the tightening torque shown below.

Proper tightening torque [N·m]

1 to 1.8

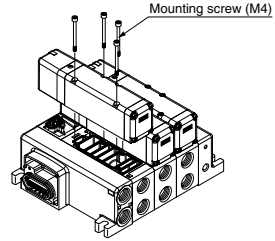

## Lead Wire Connection

### ⚠ Caution

Plug-in sub-plate (With terminal block)

- If the junction cover ① of the sub-plate is removed, you can see the plug-in type terminal block ② mounted inside the sub-plate.

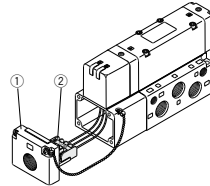

- The terminal block is marked as follows. Connect wiring to each of the power supply terminals.

| Terminal block marking                                       | A      | COM | B      | $\bar{T}$ |
|--|--------|-----|--------|-----------|
| Model VQC510 <sup>0</sup>                                    | A side | COM | —      | —         |
| VQC520 <sup>0</sup>  | A side | COM | B side | —         |
| VQC5 <sup>3</sup> / <sub>8</sub> 0 <sup>0</sup> <sub>1</sub> | A side | COM | B side | —         |

Note 1) There is no polarity. It can also be used as -COM.

Note 2) The sub-plate is double wired even for the VQC510<sup>0</sup>.

- Applicable terminal: 1.25-3s, 1.25Y-3, 1.25Y-3N, 1.25Y-3.5



# VQC5000 Series Specific Product Precautions 2

Be sure to read this before handling the products.  
Refer to back page 50 for Safety Instructions and pages 3 to 9 for 3/4/5 Port Solenoid Valve Precautions.

## Installation and Removal of Light Cover

### ⚠ Caution

#### Installation/Removal of light cover

##### • Removal

To remove the pilot cover pull it straight off. If it is pulled off at an angle, the pilot valve may be damaged or the protective O-ring may be scratched.

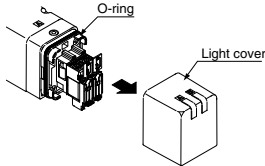

##### • Installation

Place the cover straight over the pilot assembly so that the pilot valve is not touched, and push it until the cover hook locks without twisting the protective O-ring. (When pushed in, the hook opens and locks automatically.)

## Replacement of Pilot Valve

### ⚠ Caution

##### • Removal

1) Remove the mounting screw that holds the pilot valve using a small screwdriver.

##### • Installation

1) After confirming the gasket is correctly placed under the valve, securely tighten the bolts with the proper torque shown in the table below.

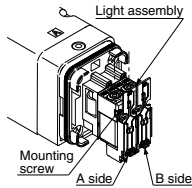

Proper tightening torque [N·m]

0.1 to 0.13

## Plug Lead Type

#### Attaching and detaching connectors

- To attach a connector, hold the lever and connector unit between your fingers and insert straight onto the pins of the solenoid valve so that the lever's pawl is pushed into the groove and locks.
- To detach a connector, remove the pawl from the groove by pushing the lever downward with your thumb, and pull the connector straight out.

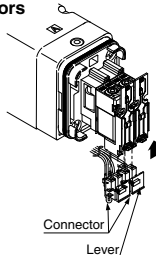

Note) Do not pull on the lead wires with excessive force. This can cause faulty and/or broken contacts.

## Internal Wiring Specifications

### ⚠ Caution

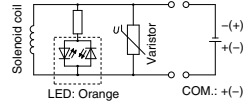

DC: Single

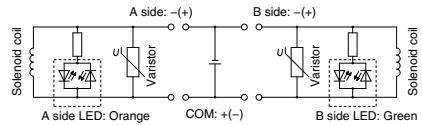

DC: Double

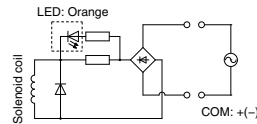

AC: Single

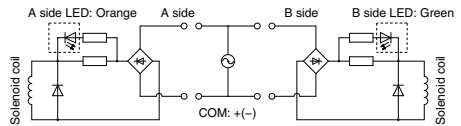

AC: Double

## How to Calculate the Flow Rate

For obtaining the flow rate, refer to front matter.

#### ■ Trademark

DeviceNet™ is a trademark of ODVA.  
EtherNet/IP™ is a trademark of ODVA.  
EtherCAT® is registered trademark and patented technology, licensed by Beckhoff Automation GmbH, Germany.

|         |
|---------|
| SV      |
| SYJ     |
| SZ      |
| VF      |
| VP4     |
| VQ 1/2  |
| VQ 4/5  |
| VQC 1/2 |
| VQC 4/5 |
| VQZ     |
| SQ      |
| VFS     |
| VFR     |
| VQ7     |