

D-SUB panel mounting frames - VS-25-A-GC-ST/ST - 1689747

Please be informed that the data shown in this PDF Document is generated from our Online Catalog. Please find the complete data in the user's documentation. Our General Terms of Use for Downloads are valid (<http://phoenixcontact.com/download>)

D-SUB panel mounting frame, shell size 3, with 25 signal contacts, pin, gender changer, shielded, IP67 degree of protection



Key Commercial Data

Packing unit	1 pc
Minimum order quantity	5 pc
Weight per Piece (excluding packing)	26.96 g
Custom tariff number	85366990
Country of origin	Germany

Technical data

Environmental Product Compliance

Mechanical characteristics

Number of positions	25
Insertion/withdrawal cycles	≥ 200
Color	gray

Ambient conditions

Ambient temperature (operation)	-40 °C ... 80 °C
---------------------------------	------------------

Material data

Flammability rating according to UL 94	V0
Housing material	PA
Contact carrier material	Polyester GF
Contact material	Copper alloy
Contact surface material	Hard gold-plated over nickel
Material	Plastic

D-SUB panel mounting frames - VS-25-A-GC-ST/ST - 1689747

Technical data

Material data

Sealing material	Flat gasket: NBR; profile gasket: EPDM
Seal material	Flat gasket: NBR; profile gasket: EPDM

Electrical characteristics

Number of positions	25
Rated current	5 A
Overvoltage category	III
Degree of pollution	2

Standards and Regulations

Flammability rating according to UL 94	V0
--	----

Classifications

eCl@ss

eCl@ss 4.0	27140816
eCl@ss 4.1	27260701
eCl@ss 5.0	27260701
eCl@ss 5.1	27260701
eCl@ss 6.0	27261203
eCl@ss 7.0	27440202
eCl@ss 8.0	27440210

ETIM

ETIM 2.0	EC000437
ETIM 3.0	EC000437
ETIM 4.0	EC000437
ETIM 5.0	EC002310

UNSPSC

UNSPSC 6.01	31261501
UNSPSC 7.0901	31261501
UNSPSC 11	31261501
UNSPSC 12.01	31261501
UNSPSC 13.2	31261501

Approvals

Approvals

D-SUB panel mounting frames - VS-25-A-GC-ST/ST - 1689747

Approvals

Approvals

EAC / EAC

Ex Approvals

Approvals submitted

Approval details

EAC

EAC

Drawings

Dimensional drawing

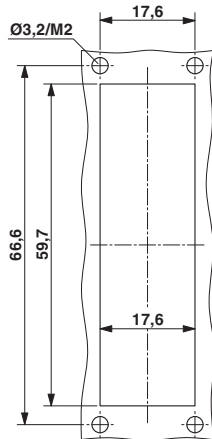

Dimensional drawing

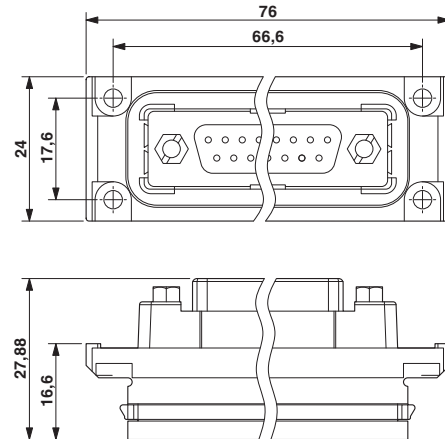

Panel cutout: VS-25-A...

D-SUB panel mounting frame
