

D-SUB panel mounting frames - VS-15-A - 1688036

Please be informed that the data shown in this PDF Document is generated from our Online Catalog. Please find the complete data in the user's documentation. Our General Terms of Use for Downloads are valid (<http://phoenixcontact.com/download>)



D-SUB panel mounting frame, shell size 2, IP67 degree of protection



Key Commercial Data

Packing unit	1 pc
Minimum order quantity	5 pc
Weight per Piece (excluding packing)	9.96 g
Custom tariff number	85389099
Country of origin	Germany

Technical data

General data

Pollution degree	2
------------------	---

Standards and Regulations

Flammability rating according to UL 94	V0
--	----

Classifications

eCl@ss

eCl@ss 4.0	27140816
eCl@ss 4.1	27260701
eCl@ss 5.0	27260701
eCl@ss 5.1	27260701
eCl@ss 6.0	27261203
eCl@ss 7.0	27440201
eCl@ss 8.0	27440201

D-SUB panel mounting frames - VS-15-A - 1688036

Classifications

ETIM

ETIM 2.0	EC000437
ETIM 3.0	EC000437
ETIM 4.0	EC000437
ETIM 5.0	EC002309

UNSPSC

UNSPSC 6.01	31261501
UNSPSC 7.0901	31261501
UNSPSC 11	31261501
UNSPSC 12.01	31261501
UNSPSC 13.2	31261501

Drawings

Dimensional drawing

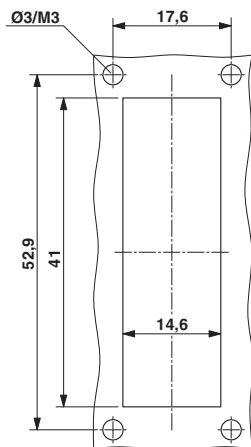

Dimensional drawing

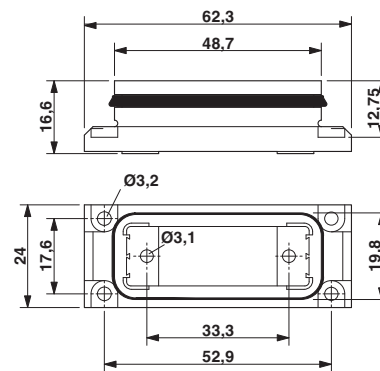

D-SUB panel mounting frame

Panel cutout