

UF92B Series

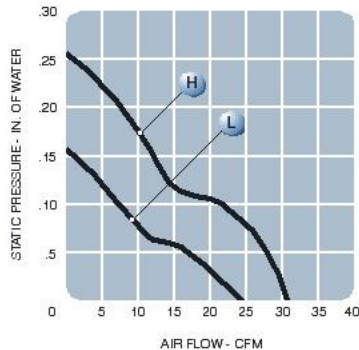

**Size: (92 x 92 x 25 mm)
3.62 x 3.62 x 0.98 inches**

UF92B series AC tubeaxial fans provide exceptional performance and value. Precision die-cast aluminum frame acts as a heat sink. UL94V-0 components. Choose from motor quality ball bearings, or sintered bronze sleeve bearings. Immediately available in 115 or 230 VAC version; dual voltage option available. Shaded pole motor. Air exhausts over struts. Choice of terminal or leadwire style.

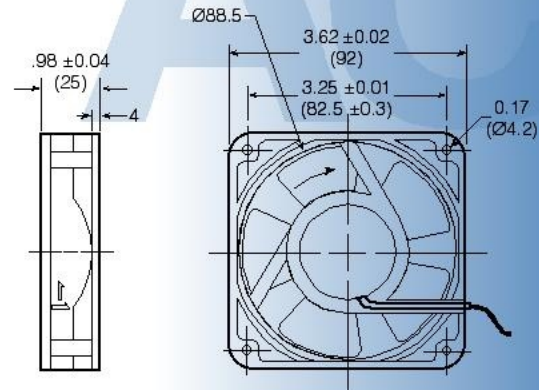

LEAD WIRE

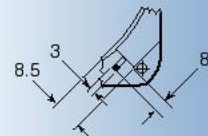

TERMINAL TYPE

Model No.	Rated Voltage V	Frequency HZ	Input Power W	Rated Current A	Locked Current A	Speed RPM	Air Volume CFM	Maximum Pressure in H ₂ O	Noise dBA	Weight OZ
UF92B12 - __ H	115	60	13	0.14	0.15	2900	31	0.26	36	10.0
UF92B23 - __ H	230	60	13	0.07	0.08	2900	31	0.26	36	10.0
UF92B12 - __ L	115	60	12	0.12	0.13	2300	25	0.16	32	10.0
UF92B23 - __ L	230	60	12	0.06	0.07	2300	25	0.16	32	10.0

AC Part Numbering System

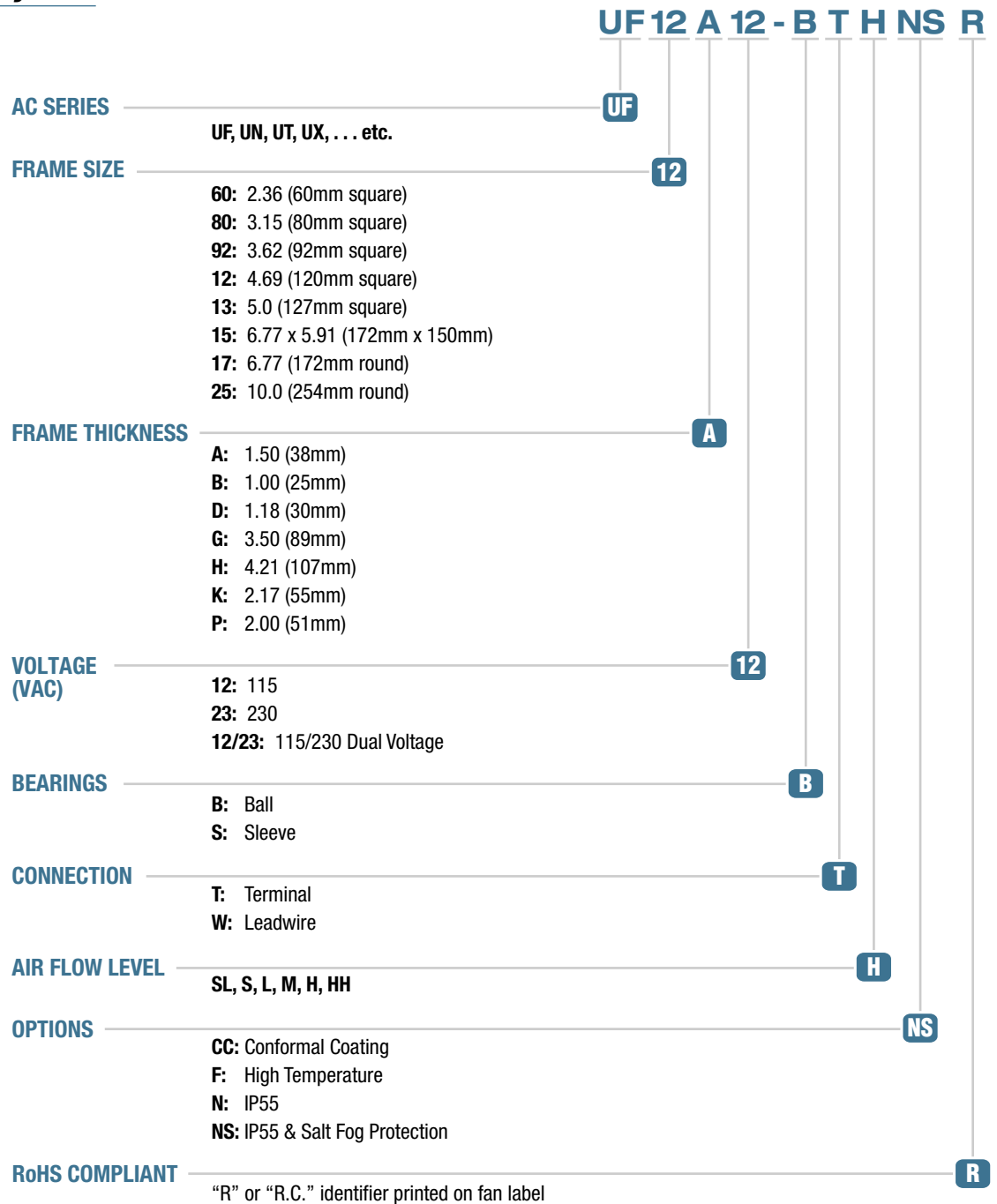

GENERAL DATA

- Ball or sleeve bearing construction
- Aluminum die-cast frame
- UL 94V0 or metal impeller
- Terminal connector or leadwire
- Leadwires
Two 22 AWG, Nom. 10.0 inches
- Impedance or thermal protection
- Dielectric strength
AC 1500V (50/60 Hz) one min.
- Operating temperature range
Ball Bearing -40°C ~ 70°C
Sleeve Bearing -20°C ~ 70°C
UF15P, UF17P -40°C ~ 60°C
- UL, C-UL, TUV, compliant,
UL, C-UL File No. E137077
TUV - R9854665
R2054331
R2054330
- Designed for continuous duty life of 50,000 hours (ball bearing)
25,000 (sleeve bearing) at 25°C