

# Single Shot (Pulse Former) TSDS Digi-Timer Timing Module



- +/-0.5% Repeat Accuracy
- No First Shot Effect
- Stable Over Voltage & Temperature
- Fixed or Adjustable Delays From 0.1 s ... 1000 m
- Totally Solid State & Encapsulated

### Description

The TSDS utilizes a stable oscillator for its time base and a C/MOS digital predetermined counting circuit to provide excellent repeat accuracy. Suitable for many applications including dispensing, welding, exposure timing--those applications requiring single shot timing.

### Operation

Input voltage must be applied before and during timing. Upon momentary or maintained closure of the initiate switch, the output is energized for a measured interval of time. At the end of the delay, the output de-energizes. Opening or reclosing the initiate switch during timing has no effect on the time delay. The output will not energize if the initiate switch is closed when input voltage is applied.

**Reset:** Reset occurs when the time delay is complete and the initiate switch is opened. Loss of input voltage resets the time delay and output.

Approvals:

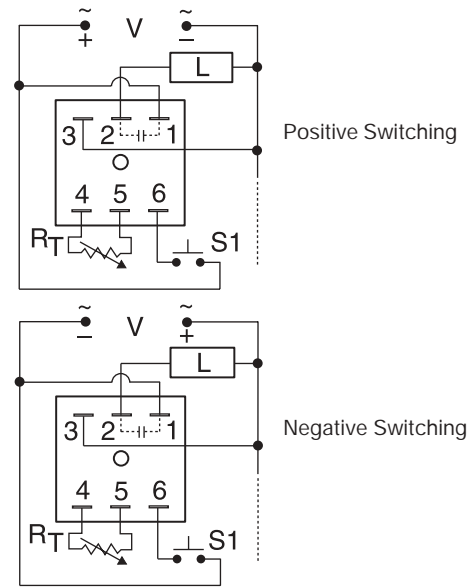

R<sub>T</sub> is used when external adjustment is ordered.

### Ordering Table

TSDS Series	X Input	X Adjustment	X Time Delay*	X Switching Mode (V DC Only)
	-1 - 12 V DC	-1 - Fixed	-0 - 0.1 ... 10 s	-P - Positive
	-2 - 24 V AC	-2 - External Adjust	-1 - 1 ... 100 s	-N - Negative
	-3 - 24 V DC		-2 - 10 ... 1000 s	
	-4 - 120 V AC		-3 - 0.1 ... 10 m	
	-6 - 230 V AC		-4 - 1 ... 100 m	
			-5 - 10 ... 1000 m	

\* If Fixed Delay is selected, insert delay [0.1 ... 1000] followed by (S) sec. or (M) min.

Example P/N: **TSDS421** Fixed - **TSDS410.1S**

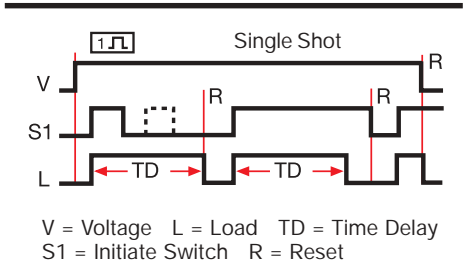

### Technical Data

<b>Time Delay</b>	Digital integrated circuitry
Type	Digital integrated circuitry
Range	0.1 s ... 1000 m in 6 adjustable ranges or fixed
Repeat Accuracy	+/-0.5 %
Tolerance (Factory Calibration)	+/-1%
Recycle Time	≤150 ms
Time Delay vs. Temperature & Voltage	≤ +/-2%
<b>Input</b>	
Voltage	12 or 24 V DC; 24, 120, or 230 V AC
Tolerance	+/-15%
DC Ripple	+/-10%
Line Frequency	50 ... 60 Hz
<b>Output</b>	
Type	Solid state
Form	Normally Open, closed during timing
Maximum Load Current	1 A steady state, 10 A inrush at 55° C
Voltage Drop	DC ≅ 1.7 V at 1 A AC ≅ 2.5 V at 1 A
DC Operation	Positive or negative switching
<b>Protection</b>	
Circuitry	Encapsulated
Dielectric Breakdown	≥ 2000 V RMS terminals to mounting surface
Insulation Resistance	≥ 100 MΩ
<b>Mechanical</b>	
Mounting	Surface mount with one #10 (M5 x 0.8) screw
Package	2 x 2 x 1.21 in. (50.8 x 50.8 x 30.7 mm)
Termination	0.25 in. (6.35 mm) male quick connect terminals
<b>Environmental</b>	
Operating/Storage Temperature	-40°C ... +75°C / -40°C ... +85°C
Humidity	95% relative, non-condensing
Weight	≅ 2.4 oz (68 g)

R <sub>T</sub> Selection Chart							
Desired Time Delay*							
Seconds		Minutes		R <sub>T</sub> Megohm		R <sub>T</sub> Megohm	
0	1	2	3	4	5		
0.1	1	10	0.1	1	0.0	10	0.0
1	10	100	1	10	0.1	100	0.3
2	20	200	2	20	0.2	200	0.6
3	30	300	3	30	0.3	300	0.9
4	40	400	4	40	0.4	400	1.2
5	50	500	5	50	0.5	500	1.5
6	60	600	6	60	0.6	600	1.8
7	70	700	7	70	0.7	700	2.1
8	80	800	8	80	0.8	800	2.4
9	90	900	9	90	0.9	900	2.7
10	100	1000	10	100	1.0	1000	3.0

\* When selecting an external R<sub>T</sub> add at least 11% for tolerance of unit and the R<sub>T</sub>.

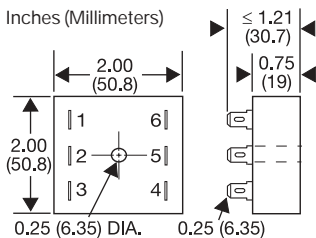

Time Delay	VTP P/N	Fig. A P/N	Fig. B P/N
0 - 0.1 ... 10 s	VTP2C	P1004-16	P1004-16-X
1 - 1 ... 100 s	VTP2G	P1004-16	P1004-16-X
2 - 10 ... 1000 s	VTP2K	P1004-16	P1004-16-X
3 - 0.1 ... 10 m	VTP2N	P1004-16	P1004-16-X
4 - 1 ... 100 m	VTP2P	P1004-16	P1004-16-X
5 - 10 ... 1000 m	VTP4R	P1004-12	P1004-12-X

### Accessories

- Mounting bracket  
P/N: P1023-6
- External adjust potentiometer  
P/N: P1004-XX
- Female quick connect  
P/N: P1015-64(AWG 14/16)
- Plug-on adjustment module  
P/N: VTP(X)(X)
- Quick connect to screw adaptor  
P/N: P1015-18
- Versa-knob  
P/N: P0700-7
- DIN rail adaptor  
P/N: P1023-20

DIN rail P/Ns: C103PM (Al) 17322005 (Steel)

See accessory pages at the end of this section.