

# Type TMR-R

## Time Lag Micro Fuse

### Radial Leaded – Long Leaded

Designed to Meet UL/CSA Specifications



www.optifuse.com (619) 593-5050

#### Agency Standards and Listings:



Voltage: 250V

#### Material

- Body: Thermoplastic UL94V0
- Pin: Copper Alloy, Tin plated
- Element: Silver Alloy

Interrupt Ratings: 50A @ 250 VAC

#### Electrical Characteristics:

Rated Current	100%	200%
50mA-10A	Carry	60 s Max

Cartridge Catalog Number	Ampere Rating	Voltage Rating	I <sup>2</sup> T
TMR-R-50mA	50mA	250V	0.0056
TMR-R-60mA	60mA		0.0075
TMR-R-63mA	63mA		0.009
TMR-R-80mA	80mA		0.014
TMR-R-100mA	100mA		0.025
TMR-R-125mA	125mA		0.044
TMR-R-160mA	160mA		0.058
TMR-R-200mA	200mA		0.1
TMR-R-250mA	250mA		0.17
TMR-R-300mA	300mA		0.22
TMR-R-315mA	315mA		0.26
TMR-R-400mA	400mA		0.32
TMR-R-500mA	500mA		0.58
TMR-R-600mA	600mA		0.67
TMR-R-630mA	630mA		0.75
TMR-R-700mA	700mA		0.85
TMR-R-800mA	800mA		0.98
TMR-R-1A	1A		2.8
TMR-R-1.25A	1.25A		3.8
TMR-R-1.5A	1.5A		4.8
TMR-R-1.6A	1.6A	5.2	
TMR-R-2A	2A	7.5	
TMR-R-2.5A	2.5A	14	
TMR-R-3A	3A	19	
TMR-R-3.15A	3.15A	22	
TMR-R-3.5A	3.5A	24	
TMR-R-4A	4A	27	
TMR-R-5A	5A	59	
TMR-R-6.3A	6.3A	100	
TMR-R-7A	7A	122	
TMR-R-8A	8A	160	
TMR-R-10A	10A	220	

#### Mechanical Dimensions: Inches [mm]

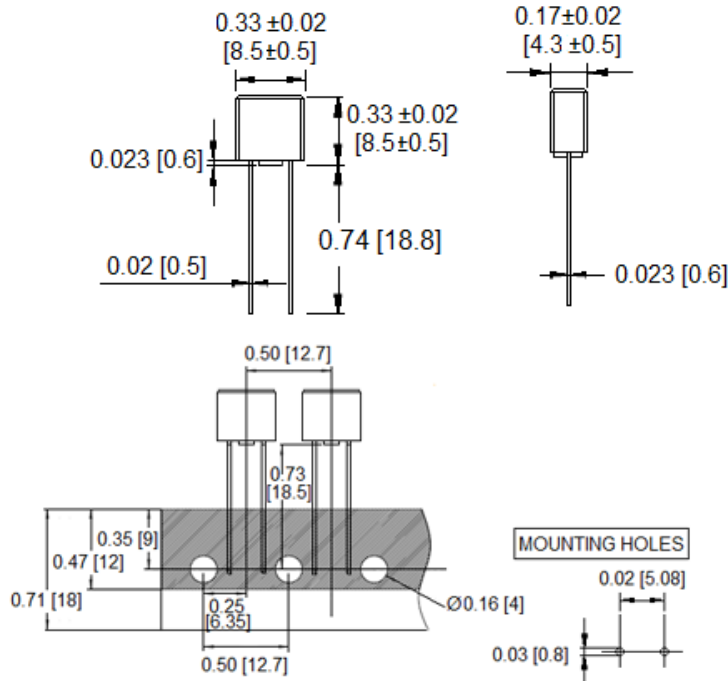

#### Warning:



- Operation beyond the specified maximum ratings or improper use may result in damage and possible electrical arcing and/or flame.
- Micro Fuse device are intended for occasional overcurrent protection. Application for repeated overcurrent condition and/or prolonged trip are not anticipated.
- Avoid contact of Micro Fuse device with chemical solvent. Prolonged contact will damage the device performance.

Note: All specifications subject to change without notice.

Rev H 03/2014 - Page: 1/1  
Code: G02-01H