

Key Features

- Compact size: 46.6 x 14.5
- Flexible connector and cable options
- Vandal resistant
- RoHS compliant



General Description

The Tango 20 is a GPS puck antenna with screw mount thread as well as an adhesive base. The two provide a firm fixation to its surface that helps prevent water ingress. Because of this, the Tango 20 is well suited to the outdoors and being exposed to the elements. Common mounting surfaces are outside on a vehicle roof, or even inside environments such as attaching to the top of vending machine. The screw mount means the Tango 20 can be fixed permanently to its surface, without fear of it being unknowingly removed. Therefore the Tango 20 is a toughened, outdoor designed, GPS antenna that will resist both the forces of nature and the forces of unwanted persons.

The Tango 20 measures at 46.6 x 14.5mm (diameter x height), so it is a compact, puck shape antenna that will allow it to fit discretely onto its surface. The Tango 20 can come with a variety of cable lengths and connectors, customised to request. The most common are found in the ordering details over page.

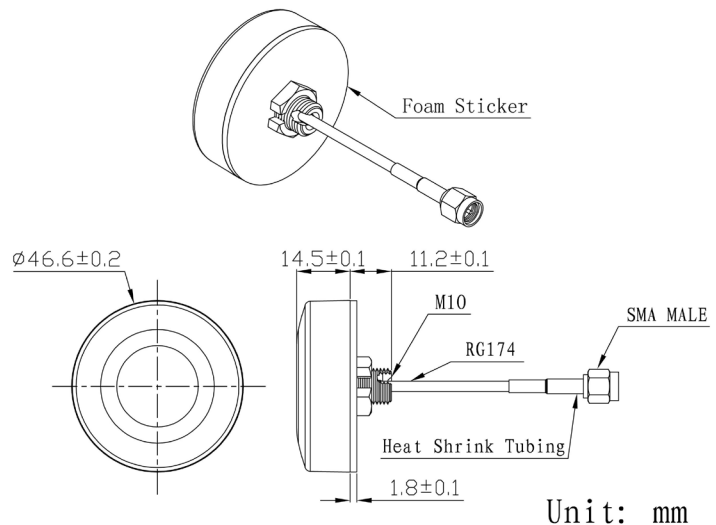

Rev 1.1

Antenna Specifications

Frequency range:	1575.42 ±1 MHz
V.S.W.R:	<1.5
Polarization:	RHCP
Gain:	5dBic (Zenith)
Impedance:	50ohm
Band Width	CF ±5MHz
Axial Ratio	3dB (max)

Mechanical Specifications

Dimensions:	46.6 x 14,5mm
Cable:	RG174
Connector:	SMA / MCX or others
Material:	ABS
Mounting method:	Screw

Environmental Specifications

Operating temperature:	-40 to +85°C
Relative humidity:	Up to 95%
Ingress protection:	IP67 (excludes cable outlet)
Vibration:	10 to 55Hz with 1.5mm amplitude 2 hours
Environmentally friendly:	RoHS compliant

LNA Specifications

Gain:	28±2dB
Noise Figure:	<1.5
Filter Insertion Loss:	<3dB
Ex-band Attenuation	12dB@CF + 50MHz/16dB@CF-50MHz
Supply Voltage:	2.2-5V DC
Current Consumption	5-15mA
VSWR	<2.0

Radiation Pattern

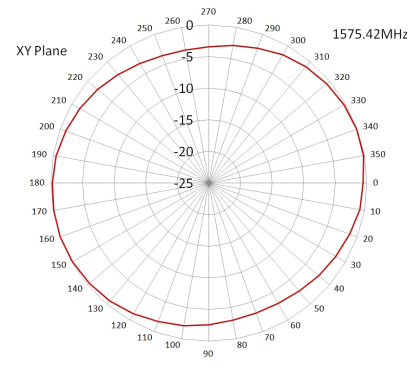
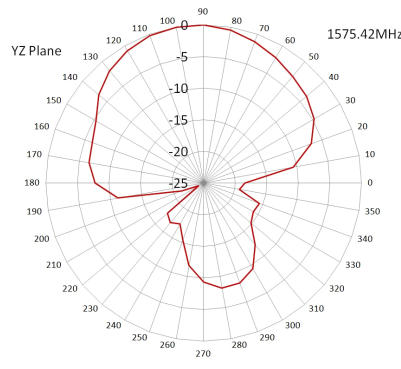
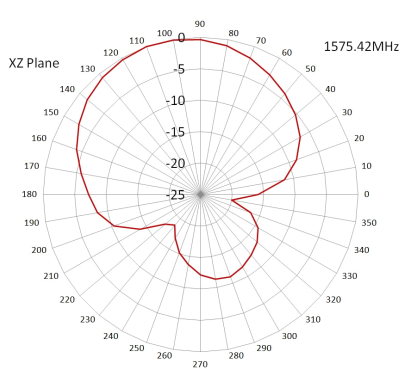

Ordering Details:

Part number	Description
TANGO20/3M/SMAM/S/S/26	GPS Puck Antenna with Screw Mount 3m RG174 Cable and SMA Male Connector
TANGO20/2M/SMAM/S/S/26	GPS Puck Antenna with Screw Mount 2m RG174 Cable and SMA Male Connector
TANGO20/3M/FMEF/S/S/26	GPS Puck Antenna with Screw Mount 3m RG174 Cable and FME Female Connector
TANGO20/2M/FMEF/S/S/26	GPS Puck Antenna with Screw Mount 2m RG174 Cable and FME Female Connector

Siretta is a division of Sequoia Technology Group Ltd

Registered in England No. 4004881
VAT Registration No. GB614 5653 45

Siretta
Basingstoke Road
Spencers Wood
Reading
Berkshire RG7 1PW

sales +44(0)118 976 9014
fax +44(0)118 976 9020
email info@siretta.co.uk
web www.siretta.co.uk