

MINIATURE CIRCUIT BREAKERS

# SU200M Datasheet

Branch protection acc. to CSA C22.2 No.5 / UL 489



The miniature circuit breaker SU200 M is ABB's solution for UL 489 branch circuit protection up to 480 Y/277 V AC and 96 V DC. This circuit breaker is an all-round device for AC and DC applications for universal use in North American and global markets due to its approvals acc. to the international standards UL, CSA and IEC. Moreover, SU 200 M is fully compatible with System pro M compact® UL 489 accessories.

—  
01 SU201M / SU203M  
miniature circuit breakers

## Features

- High performance MCB with 10 kA interrupting capacity acc. to UL 489 / CSA 22.2 No. 5 and 15 kA breaking capacity acc. to IEC/EN 60947-2
- Certified up to  $I_n = 40$  A at 480 Y/277 V AC acc. to UL 489 / CSA 22.2 No. 5
- Certified for AC and DC use acc. to UL and CSA
- 40 °C reference temperature acc. to UL and CSA
- Current limiting acc. to UL 489
- Clear contact position indication in red/green ("real CPI")
- Laser printing provides clear product information on device
- Robust thermoplastic housing material for better protection against external influences
- Unique, patented twin terminal for wiring up to 35 mm<sup>2</sup> with captive screws
- Possibility to add more than one wire per terminal up to 25A

## Standards and approvals

### Standards

UL 489  
CSA 22.2. No. 5  
IEC/EN 60947-2

### Approvals

UL 489	US
CSA 22.2. No. 5	CA
VDE	DE
CCC	CN

# Miniature Circuit Breaker SU200M

## Technical data

<b>General Data</b>	
Standards	UL 489, CSA 22.2 No. 5, IEC/EN 60947-2
Poles	1P, 2P, 3P, 4P
Tripping characteristics	C, K, Z
Rated current $I_n$	0.2...63A
Rated frequency f	50 / 60 Hz, DC (0 Hz)
Rated insulation voltage $U_i$ acc. to IEC/EN 60664-1	250 Vac (phase to ground), 440 Vac (phase to phase)
Overvoltage category	III
Pollution degree	3
<b>Data acc. to UL / CSA</b>	
Rated voltage	1P: 240 Vac up to 63A 1P: 277 Vac up to 40A (C and Z characteristic) 1P: 277 Vac up to 35A (K characteristic) 1P: 48Vdc up to 63A 2P +: 480Y / 277 Vac up to 40A (C and Z characteristic) 2P +: 480Y / 277 Vac up to 35A (K characteristic) 2P +: 240 Vac up to 63A 2P +: 96 Vdc (2P in series)
Rated interrupting capacity acc. to UL 1077	-
Short-circuit current rating acc. to UL 489	10kA
Application	-
Reference temperature for tripping characteristics	40 °C
Electrical endurance	6,000 ops (AC), 6,000 ops. (DC); 1 cycle (1s - ON, 9s - OFF)
<b>Mechanical Data</b>	
Housing	Insulation group II, RAL 7035
Toggle	Insulation group II, black, sealable
Contact position indication	CPI (red ON / green OFF)
Protection degree acc. to EN 60529	IP20, IP40 in enclosure with cover
Mechanical endurance	20,000 ops.
Shock resistance acc. to IEC/EN 60068-2-27	25 g - 2 shocks - 13 ms
Vibration resistance acc. to IEC/EN 60068-2-6	5g - 20 cycles at 5...150...5 Hz with load 0.8 $I_n$
Environmental conditions (damp heat) acc. to IEC/EN 60068-2-30	28 cycles with 55°C/90-96% and 25°C/95-100%
Ambient temperature	-25 ... +55 °C (with performance derating possibility)
Storage temperature	-40 ... +70 °C
<b>Installation</b>	
Terminal	Failsafe bi-directional cylinder-lift terminal
Cross-section of conductors (top / bottom) Solid, Stranded	35 mm <sup>2</sup> / 35 mm <sup>2</sup>
Flexible	25 mm <sup>2</sup> / 25 mm <sup>2</sup> 18 - 4 AWG
Cross-section of busbars (top / bottom)	10 mm <sup>2</sup> / 10 mm <sup>2</sup> 14 - 8 AWG
Tightening Torque	2.8 Nm AWG 18-16: 8.85 in-lbs. AWG 14-10: 17.7 in-lbs. AWG 8-4: 39.8 in-lbs.
Screwdriver	No. 2 Pozidrive
Mounting	On DIN rail 35 mm acc. to EN 60715 by fast clip
Mounting position	any
Supply	optional
<b>Dimensions and weight</b>	
Mounting dimensions acc. to DIN 43880	Mounting dimension 1
Pole dimensions (H x D x W)	88 x 69 x 17.5 mm
Pole weight	approx. 115 g
<b>Combination with aux. elements</b>	
Auxiliary contact	Yes
Signal contact	Yes
Shunt trip	Yes

# Miniature Circuit Breaker SU200 M

## Tripping characteristics

1) The thermal releases are calibrated to a nominal reference ambient temperature of 40 °C. In the case of higher ambient temperatures, the current values fall by approx. 6 % for each 10 K temperature rise.

2) The indicated tripping values of electromagnetic tripping devices apply to a frequency of 50/60 Hz. The thermal release operates independent of frequency.

3) As from operating temperature (after  $I_1 > 1h$ )

### Tripping characteristics

Acc. to	Tripping characteristics	Rated current	Thermal release <sup>1)</sup>		Tripping time	Electromagnetic release <sup>2)</sup>	
			conventional non-tripping current	conventional tripping current		Range of instantaneous tripping	Tripping time
UL489	C	0.5 to 63 A	$I_1$	$1.03 \cdot I_n$	$> 1 h$	$5 \cdot I_n$	$> 0.2 s$
				$1.25 \cdot I_n$	$< 1 h$ <sup>3)</sup>		$10 \cdot I_n$
	K	0.5 to 63 A	$I_1$	$1.03 \cdot I_n$	$> 1 h$	$10 \cdot I_n$	$> 0.2 s$
				$1.25 \cdot I_n$	$< 1 h$ <sup>3)</sup>		$14 \cdot I_n$
	Z	0.5 to 63 A	$I_1$	$1.03 \cdot I_n$	$> 1 h$	$2 \cdot I_n$	$> 0.2 s$
				$1.25 \cdot I_n$	$< 1 h$ <sup>3)</sup>		$3 \cdot I_n$

C characteristic

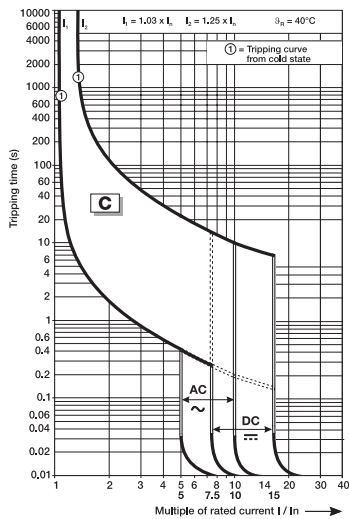

K characteristic

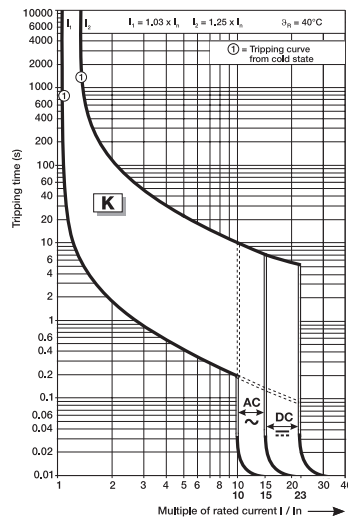

Z characteristic

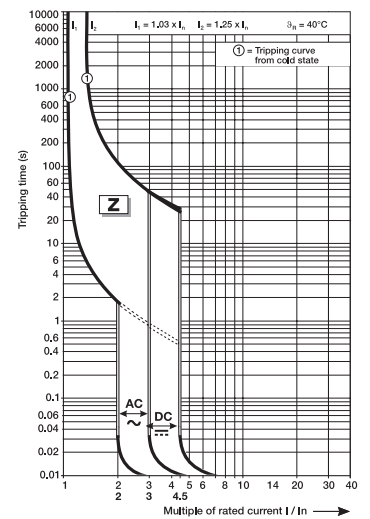

## Miniature Circuit Breaker SU200M Temperature Derating

### Deviating ambient temperature

The rated value of the current of a miniature circuit breaker of SU200 M series refers to a reference ambient temperature of 40 °C acc. to UL489 or UL/CSA. The

following table shows derating factors for ambient temperature from -40 °C to 70 °C for the characteristics C, K, Z.

Maximum operating current(A) at ambient temperature T													
Standard	Rated current (A)	- 40 °C	- 30 °C	- 20 °C	- 10 °C	0 °C	10 °C	20 °C	30 °C	40 °C	50 °C	60 °C	70 °C
	0.2	0.27	0.26	0.25	0.24	0.23	0.22	0.22	0.21	0.2	0.19	0.19	0.18
	0.3	0.40	0.39	0.37	0.36	0.35	0.33	0.32	0.31	0.3	0.29	0.28	0.27
	0.5	0.67	0.64	0.62	0.60	0.58	0.56	0.54	0.52	0.5	0.48	0.46	0.45
	0.75	1.00	0.97	0.93	0.90	0.87	0.84	0.81	0.78	0.75	0.72	0.70	0.67
	1	1.34	1.29	1.24	1.20	1.16	1.12	1.08	1.04	1	0.96	0.93	0.89
	1.6	1.74	1.68	1.62	1.56	1.50	1.45	1.40	1.35	1.3	1.25	1.21	1.16
	2	2.67	2.58	2.49	2.40	2.31	2.23	2.15	2.07	2	1.93	1.85	1.79
	3	4.01	3.87	3.73	3.60	3.47	3.35	3.23	3.11	3	2.89	2.78	2.68
	4	5.35	5.16	4.97	4.80	4.63	4.46	4.30	4.15	4	3.85	3.71	3.57
	5	6.69	6.45	6.22	6.00	5.78	5.58	5.38	5.19	5	4.82	4.64	4.47
	6	8.02	7.74	7.46	7.20	6.94	6.69	6.45	6.22	6	5.78	5.56	5.36
	8	10.70	10.32	9.95	9.59	9.25	8.92	8.60	8.30	8	7.70	7.42	7.14
<b>UL489</b>	10	13.37	12.90	12.44	11.99	11.56	11.15	10.75	10.37	10	9.63	9.27	8.93
	13	17.38	16.76	16.17	15.59	15.03	14.50	13.98	13.48	13	12.52	12.06	11.61
	15	20.06	19.34	18.65	17.99	17.35	16.73	16.13	15.56	15	14.45	13.91	13.40
	16	21.40	20.63	19.90	19.19	18.50	17.84	17.21	16.59	16	15.41	14.84	14.29
	20	26.75	25.79	24.87	23.98	23.13	22.30	21.51	20.74	20	19.26	18.55	17.86
	25	33.43	32.24	31.09	29.98	28.91	27.88	26.88	25.93	25	24.08	23.18	22.33
	30	40.12	38.69	37.31	35.98	34.69	33.45	32.26	31.11	30	28.89	27.82	26.79
	32	42.79	41.27	39.79	38.37	37.01	35.69	34.41	33.18	32	30.82	29.68	28.58
	35	46.81	45.14	43.53	41.97	40.47	39.03	37.64	36.30	35	33.71	32.46	31.26
	40	53.49	51.58	49.74	47.97	46.26	44.61	43.01	41.48	40	38.52	37.09	35.72
	50	66.87	64.48	62.18	59.96	57.82	55.76	53.77	51.85	50	48.15	46.37	44.65
	60	80.24	77.38	74.61	71.95	69.39	66.91	64.52	62.22	60	57.78	55.64	53.58
	63	84.25	81.24	78.35	75.55	72.85	70.25	67.75	65.33	63	60.67	58.42	56.26

## Miniature Circuit Breaker SU200 M Derating

Influence of adjacent devices, internal resistance and power loss

### Influence of adjacent devices

If several miniature circuit breakers are installed directly side by side with high load on all poles, a correction factor has to be applied to the rated current (see table). If distance pieces are used, the factor is not to be considered.

No. of adjacent devices	Factor F
1	-
2...3	0.9
4...5	0.8
≥ 6	0.75

### Internal resistance and power loss per pole (SU200M/SU200MR)

Rated current (A)	C and K tripping characteristics		Z tripping characteristic	
	Internal resistance <sup>(1)</sup> (mΩ)	Power loss (W)	Internal resistance <sup>(1)</sup> (mΩ)	Power loss (W)
0.2	42500 / 25300	1.7 / 1.01	-	-
0.3	18889 / 13700	1.7 / 1.23	-	-
0.5	5600 / 4740	1.4 / 1.19	9000	2.3
0.75	2489 / 2067	1.4 / 1.16	-	-
1	1400 / 1270	1.4 / 1.27	2200	2.2
1.6 (1.5 for SU200MR)	703 / 610	1.8 / 1.56	1000	2.6
2	450 / 442	1.8 / 1.77	650	2.6
3	178 / 140	1.6 / 1.26	250	2.3
4	113 / 109	1.8 / 1.75	140	2.2
5	50 / 50	1.31 / 1.26	100	2.5
6	56 / 54	2.0 / 1.94	70	2.5
8	23 / 22	1.5 / 1.41	28	1.8
10	21 / 18.2	2.1 / 1.82	21	2.1
13	14 / 14.8	2.3 / 2.5	17	2.9
15	11 / 8.1	2.4 / 1.83	13	2.9
16	9.8 / 11.1	2.5 / 2.83	10	2.6
20	6.3 / 8.5	2.5 / 3.40	6.5	2.6
25	5.1 / 5.5	3.2 / 3.43	5.1	3.2
30	3.9 / 3.8	3.5 / 3.39	3.9	3.5
32	3.6 / 4.6	3.7 / 4.70	3.6	3.7
35	3.3 / 3.9	4.1 / 4.76	3.3	4.1
40	2.8 / 2.8	4.54 / 4.40	2.8	4.5
50	1.8 / 1.7	4.5 / 4.25	1.8	4.5
60	1.4 / 1.7	4.9 / 6.18	1.4	4.9
63	1.4 / 1.9	5.4 / 7.56	1.4	5.4

Internal resistances are subject to application specific and environment-specific conditions and are therefore to be considered as typical values.

## Miniature Circuit Breaker SU200M

Current limiting -  $I_{peak}$  and  $I^2t$  values acc. to UL489

Type	Voltage	Current (A)	Power Factor	Phase	$I_{peak}$ (kA)	$I^2t$ (kA <sup>2</sup> S)
SU203M-K0.2	480Y/277	10000	0.45-0.5	3	0.026	0.008
SU203M-K7	480Y/277	4095	0.45-0.5	3	2.3	11.9
SU203M-K7	480Y/277	7500	0.45-0.5	3	3.4	16.7
SU203M-K7	480Y/277	10000	0.45-0.5	3	4.6	19.0
SU203M-K20	480Y/277	4095	0.45-0.5	3	2.9	18.1
SU203M-K20	480Y/277	7500	0.45-0.5	3	4.3	28.1
SU203M-K20	480Y/277	10000	0.45-0.5	3	6.4	34.6
SU203M-K35	480Y/277	4095	0.45-0.5	3	3.4	27.9
SU203M-K35	480Y/277	7500	0.45-0.5	3	4.7	33.1
SU203M-K35	480Y/277	10000	0.45-0.5	3	9.0	72.0
SU203M-C40	480Y/277	4095	0.45-0.5	3	3.4	22.8
SU203M-C40	480Y/277	7500	0.45-0.5	3	5.1	42.5
SU203M-C40	480Y/277	10000	0.45-0.5	3	9.3	74.6
SU201M-K0.2	277	10000	0.45-0.5	1	0.7	0.092
SU201M-K7	277	4095	0.45-0.5	1	2.5	10.5
SU201M-K7	277	7500	0.45-0.5	1	3.4	16.9
SU201M-K7	277	10000	0.45-0.5	1	3.4	14.5
SU201M-K20	277	4095	0.45-0.5	1	2.8	14.7
SU201M-K20	277	7500	0.45-0.5	1	4.1	23.5
SU201M-K20	277	10000	0.45-0.5	1	4.7	32.5
SU201M-K35	277	4095	0.45-0.5	1	3.0	19.8
SU201M-K35	277	7500	0.45-0.5	1	4.7	36.5
SU201M-K35	277	10000	0.45-0.5	1	4.4	22.1
SU201M-C40	277	4095	0.45-0.5	1	3.6	22.9
SU201M-C40	277	7500	0.45-0.5	1	5.3	52.6
SU201M-C40	277	10000	0.45-0.5	1	5.9	44.9
SU203M-K63	240	4095	0.45-0.5	3	3.6	19.9
SU203M-K63	240	7500	0.45-0.5	3	5.1	33.0
SU203M-K63	240	10000	0.45-0.5	3	6.3	43.3
SU201M-K63	240	4095	0.45-0.5	1	3.9	33.8
SU201M-K63	240	7500	0.45-0.5	1	5.2	43.8
SU201M-K63	240	10000	0.45-0.5	1	6.5	61.8

# Miniature Circuit Breaker SU200M

## Accessory overview and dimensional drawing

- 
- H:**  
Auxiliary contact  
(S2C-H6RU)
- S/H:**  
Signal contact  
(S2C-S6RU)
- ST:**  
Shunt trip for SU200M MCB  
(S2C-A...U)

The certification of the accessories has been done with one accessory only. The number of electrical operations is limited to 4,000 operations for the maximum combinations and the combinations including shunt trips.

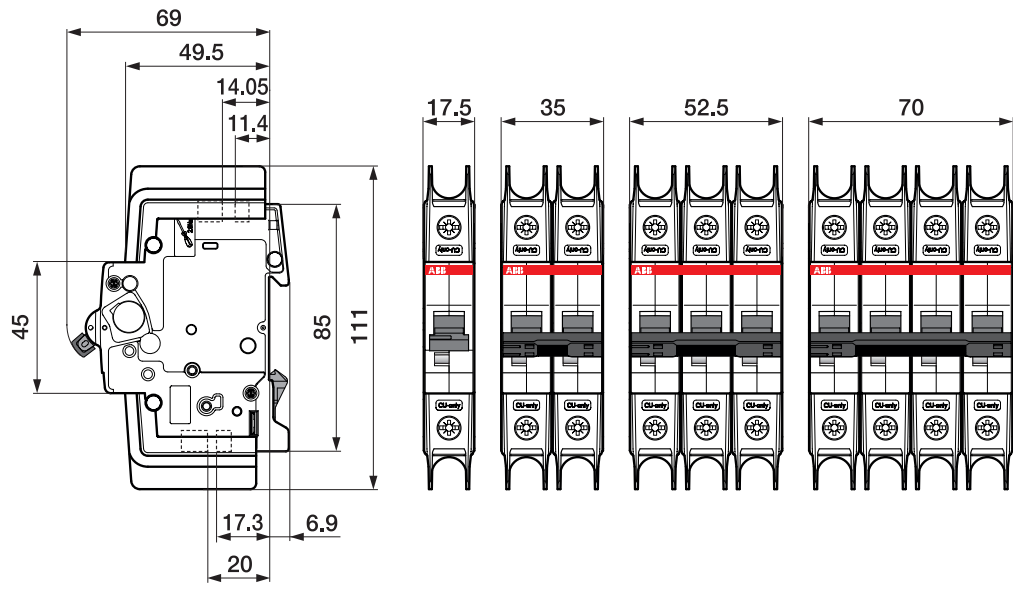
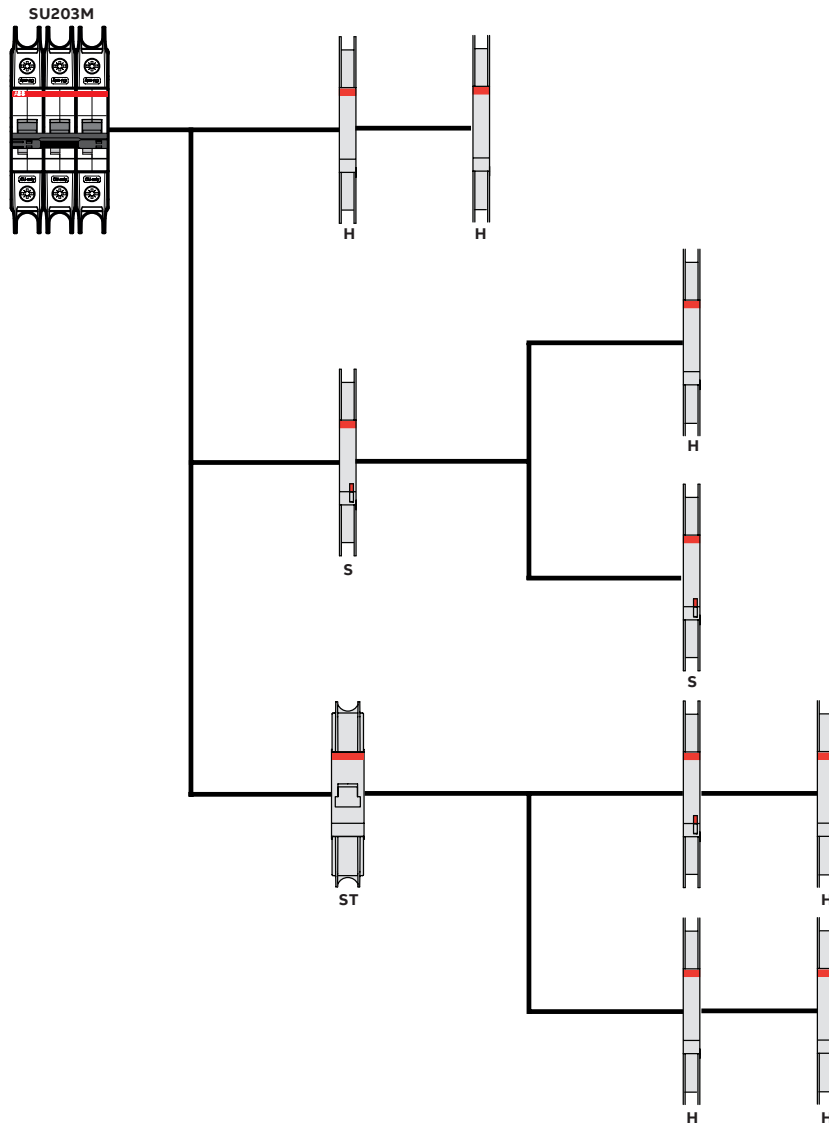

## Miniature Circuit Breaker SU200M

Ordering data characteristic C

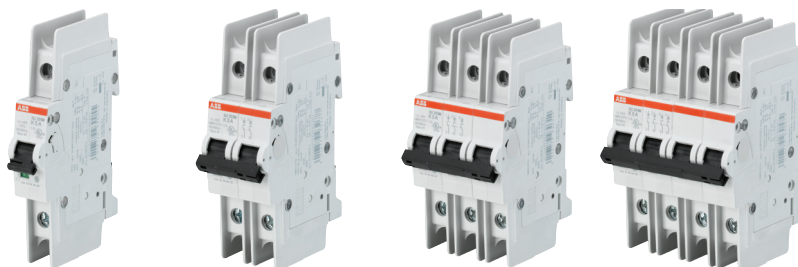

Type	Rated Current	1 pole Part number	2 poles Part number	3 poles Part number	4 poles Part number
SU200M-C	0.5 A	SU201M-C0.5	SU202M-C0.5	SU203M-C0.5	SU204M-C0.5
	1.0 A	SU201M-C1	SU202M-C1	SU203M-C1	SU204M-C1
	1.6 A	SU201M-C1.6	SU202M-C1.6	SU203M-C1.6	SU204M-C1.6
	2.0 A	SU201M-C2	SU202M-C2	SU203M-C2	SU204M-C2
	3.0 A	SU201M-C3	SU202M-C3	SU203M-C3	SU204M-C3
	4.0 A	SU201M-C4	SU202M-C4	SU203M-C4	SU204M-C4
	5.0 A	SU201M-C5	SU202M-C5	SU203M-C5	SU204M-C5
	6.0 A	SU201M-C6	SU202M-C6	SU203M-C6	SU204M-C6
	7.0 A	SU201M-C7	SU202M-C7	SU203M-C7	SU204M-C7
	8.0 A	SU201M-C8	SU202M-C8	SU203M-C8	SU204M-C8
	10.0 A	SU201M-C10	SU202M-C10	SU203M-C10	SU204M-C10
	13.0 A	SU201M-C13	SU202M-C13	SU203M-C13	SU204M-C13
	15.0 A	SU201M-C15	SU202M-C15	SU203M-C15	SU204M-C15
	16.0 A	SU201M-C16	SU202M-C16	SU203M-C16	SU204M-C16
	20.0 A	SU201M-C20	SU202M-C20	SU203M-C20	SU204M-C20
	25.0 A	SU201M-C25	SU202M-C25	SU203M-C25	SU204M-C25
	30.0 A	SU201M-C30	SU202M-C30	SU203M-C30	SU204M-C30
	32.0 A	SU201M-C32	SU202M-C32	SU203M-C32	SU204M-C32
	35.0 A	SU201M-C35	SU202M-C35	SU203M-C35	SU204M-C35
	40.0 A	SU201M-C40	SU202M-C40	SU203M-C40	SU204M-C40
	50.0 A	SU201M-C50	SU202M-C50	SU203M-C50	SU204M-C50
	60.0 A	SU201M-C60	SU202M-C60	SU203M-C60	SU204M-C60
	63.0 A	SU201M-C63	SU202M-C63	SU203M-C63	SU204M-C63



## Miniature Circuit Breaker SU200M

Ordering data characteristic K

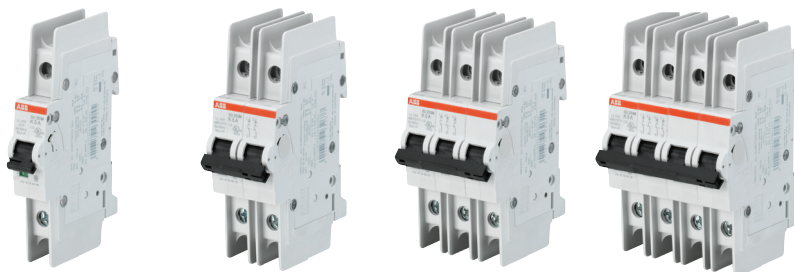

Type	Rated Current	1 pole Part number	2 poles Part number	3 poles Part number	4 poles Part number
SU200M-K	0.2 A	SU201M-K0.2	SU202M-K0.2	SU203M-K0.2	SU204M-K0.2
	0.3 A	SU201M-K0.3	SU202M-K0.3	SU203M-K0.3	SU204M-K0.3
	0.5 A	SU201M-K0.5	SU202M-K0.5	SU203M-K0.5	SU204M-K0.5
	0.75 A	SU201M-K0.75	SU202M-K0.75	SU203M-K0.75	SU204M-K0.75
	1.0 A	SU201M-K1	SU202M-K1	SU203M-K1	SU204M-K1
	1.6 A	SU201M-K1.6	SU202M-K1.6	SU203M-K1.6	SU204M-K1.6
	2.0 A	SU201M-K2	SU202M-K2	SU203M-K2	SU204M-K2
	3.0 A	SU201M-K3	SU202M-K3	SU203M-K3	SU204M-K3
	4.0 A	SU201M-K4	SU202M-K4	SU203M-K4	SU204M-K4
	5.0 A	SU201M-K5	SU202M-K5	SU203M-K5	SU204M-K5
	6.0 A	SU201M-K6	SU202M-K6	SU203M-K6	SU204M-K6
	7.0 A	SU201M-K7	SU202M-K7	SU203M-K7	SU204M-K7
	8.0 A	SU201M-K8	SU202M-K8	SU203M-K8	SU204M-K8
	10.0 A	SU201M-K10	SU202M-K10	SU203M-K10	SU204M-K10
	13.0 A	SU201M-K13	SU202M-K13	SU203M-K13	SU204M-K13
	15.0 A	SU201M-K15	SU202M-K15	SU203M-K15	SU204M-K15
	16.0 A	SU201M-K16	SU202M-K16	SU203M-K16	SU204M-K16
	20.0 A	SU201M-K20	SU202M-K20	SU203M-K20	SU204M-K20
	25.0 A	SU201M-K25	SU202M-K25	SU203M-K25	SU204M-K25
	30.0 A	SU201M-K30	SU202M-K30	SU203M-K30	SU204M-K30
	32.0 A	SU201M-K32	SU202M-K32	SU203M-K32	SU204M-K32
	35.0 A	SU201M-K35	SU202M-K35	SU203M-K35	SU204M-K35
	40.0 A	SU201M-K40	SU202M-K40	SU203M-K40	SU204M-K40
	50.0 A	SU201M-K50	SU202M-K50	SU203M-K50	SU204M-K50
	60.0 A	SU201M-K60	SU202M-K60	SU203M-K60	SU204M-K60
	63.0 A	SU201M-K63	SU202M-K63	SU203M-K63	SU204M-K63

## Miniature Circuit Breaker SU200M

Ordering data characteristic Z

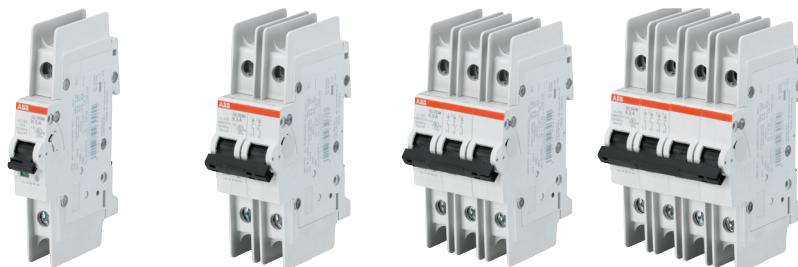

Type	Rated Current	Part number 1p devices	Part number 2p devices	Part number 3p devices	Part number 4p devices
SU200M-Z	0.5 A	SU201M-Z0.5	SU202M-Z0.5	SU203M-Z0.5	SU204M-Z0.5
	1.0 A	SU201M-Z1	SU202M-Z1	SU203M-Z1	SU204M-Z1
	1.6 A	SU201M-Z1.6	SU202M-Z1.6	SU203M-Z1.6	SU204M-Z1.6
	2.0 A	SU201M-Z2	SU202M-Z2	SU203M-Z2	SU204M-Z2
	3.0 A	SU201M-Z3	SU202M-Z3	SU203M-Z3	SU204M-Z3
	4.0 A	SU201M-Z4	SU202M-Z4	SU203M-Z4	SU204M-Z4
	5.0 A	SU201M-Z5	SU202M-Z5	SU203M-Z5	SU204M-Z5
	6.0 A	SU201M-Z6	SU202M-Z6	SU203M-Z6	SU204M-Z6
	7.0 A	SU201M-Z7	SU202M-Z7	SU203M-Z7	SU204M-Z7
	8.0 A	SU201M-Z8	SU202M-Z8	SU203M-Z8	SU204M-Z8
	10.0 A	SU201M-Z10	SU202M-Z10	SU203M-Z10	SU204M-Z10
	13.0 A	SU201M-Z13	SU202M-Z13	SU203M-Z13	SU204M-Z13
	15.0 A	SU201M-Z15	SU202M-Z15	SU203M-Z15	SU204M-Z15
	16.0 A	SU201M-Z16	SU202M-Z16	SU203M-Z16	SU204M-Z16
	20.0 A	SU201M-Z20	SU202M-Z20	SU203M-Z20	SU204M-Z20
	25.0 A	SU201M-Z25	SU202M-Z25	SU203M-Z25	SU204M-Z25
	30.0 A	SU201M-Z30	SU202M-Z30	SU203M-Z30	SU204M-Z30
	32.0 A	SU201M-Z32	SU202M-Z32	SU203M-Z32	SU204M-Z32
	35.0 A	SU201M-Z35	SU202M-Z35	SU203M-Z35	SU204M-Z35
	40.0 A	SU201M-Z40	SU202M-Z40	SU203M-Z40	SU204M-Z40
	50.0 A	SU201M-Z50	SU202M-Z50	SU203M-Z50	SU204M-Z50
	60.0 A	SU201M-Z60	SU202M-Z60	SU203M-Z60	SU204M-Z60
	63.0 A	SU201M-Z63	SU202M-Z63	SU203M-Z63	SU204M-Z63