



## Applications:

- Myers™ hubs are used in the termination of electrical circuits through wall of the enclosure
- Designed for use indoors or outdoors with rigid conduit and IMC
- Ideal for pharmaceutical, chemical and food processing, pulp/paper, nuclear, solar and commercial construction applications
- Resistant to a variety of chemicals, including acetic, citric and salt water
- Special design of o-ring gasket provides excellent environmental ratings and chemical resistance
- Hub is provided with a stainless steel ground nut

## Features:

- Wide range of styles, trade sizes and materials to meet customer requirements and preferences
- Multiple certifications provide users peace of mind
- Easy installation and smooth pulling service for labor savings
- Tapered female threads for rigid/IMC conduit, NPSM male threads

## Certifications and compliances:

- NEC/CEC:
  - Class I, Division 2
  - Class II, Divisions 1 & 2
  - Class III, Divisions 1 & 2
  - Class I, Zone 1, AEx e II
  - Class I, Zone 1, Ex e II
- cULus Listed
  - UL Standard 514B
  - CSA Standard C22.2 No. 18
- NEMA Type 2, 3, 3R, 4, 4X, 12 (std. hub and ground hub)
- IEC:
  - STGK:
    - ATEX Certified ITS12ATEX47591X Ex  II 2G Ex e IIC Gb to EN 60079-0:2009, EN 60079-7:2007, and EN 60079-14 Standards Ta -15°C to 120°C
    - IECEX Certified IECEX ETL 12.0009X Ex e IIC Gb to IEC 60079-0:2007-10, Edition 5, IEC 60079-7:2006-07, Edition 4 and IEC 60079-14 Standards Ta -15°C to 120°C
  - IP66
  - SSTGK:
    - ATEX Certified DEMKO 18 ATEX 2002X,  II 2G Ex eb IIC Gb to EN IEC 60079-0:2018 and EN IEC 60079-7:2015 +A1:2018 standards Ta -55°C to 180°C
    - IECEX Certified IECEX UL 18.0007X, Ex eb IIC Gb to IEC 60079-0:2017 and IEC 60079-7:2017 standards Ta -55°C to 180°C
  - IP66



## Standard materials:

- Nut: Zinc (Zamek-2, Zamek-3), aluminum (Al 360), stainless (316)
- Body: Zinc (Zamek-2, Zamek-3), aluminum (Al 360), stainless (316)
- Insuliner: Lexan, PEEK GF15 (SSTGK only)
- O-Ring: Viton; silicone (SSTGK only)
- Ground Screw: Steel/stainless steel

## Standard finishes:

- Aluminum – natural
- Zinc – natural
- Stainless – natural

## Options:

- | Description  | Suffix |
|--|--------|
| • Nickel-chrome plate finish (available on zinc hubs only) ..... | CP     |

## Myers hubs design features

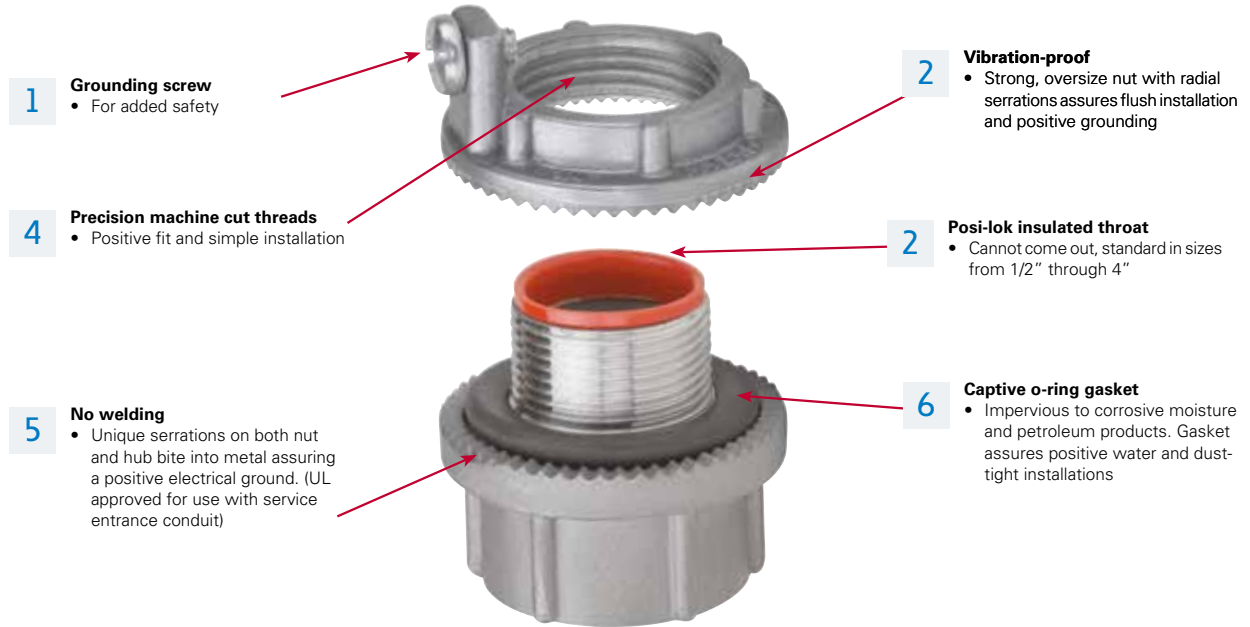

Available in trade sizes 3/8" through 6"

### Hub Basic Scru-Tite®

Hubs are ideal for general use with rigid conduit. Provides positive seal and electrical ground.



Available in trade sizes 1/2" through 6"

### Ground hub

Combines all of the features of the Hub Basic Scru-Tite® plus the additional feature of the grounding screw on the locknut.



Stainless steel now rated for -55°C to 180°C

Available in trade sizes 1/2" through 4"

### ATEX rated hub

Hub is listed for use in hazardous (classified) locations to IECEx-ATEX certifications. Ideal for global requirements and OEM's shipping material worldwide.



### Through-bulkhead fitting

Hubs are the perfect method for installing hubs on cast boxes or through thicker walls.



### Metric to NPT adapter

Used to convert a threaded metric entry to a NPT entry.



### Drain plugs

Designed to install in the bottom of an enclosure to drain any accumulated condensation. Available in aluminum or stainless steel construction.

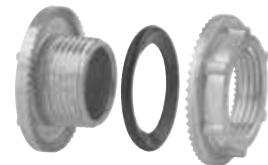

### Cap-off

Designed to install in enclosure to provide environmental cap for unused entries or knockouts.

## HUB BASIC SCRU-TITE® – NEMA 2, 3, 3R, 4, 4X, 12

Zinc

UL File No. E-27258



Conduit hubs

Cat. #	Size	Unit qty.	Wt. lbs. per 100
ST 03 <sup>Ⓞ</sup>	3/8"	25	11
ST 1 <sup>Ⓞ</sup>	1/2"	25	19
ST 2 <sup>Ⓞ</sup>	3/4"	25	27
ST 3 <sup>Ⓞ</sup>	1"	25	40
ST 4 <sup>Ⓞ</sup>	1 1/4"	10	51
ST 5 <sup>Ⓞ</sup>	1 1/2"	10	68
ST 6 <sup>Ⓞ</sup>	2"	10	92
ST 7 <sup>Ⓞ</sup>	2 1/2"	5	210
ST 8 <sup>Ⓞ</sup>	3"	2	245
ST 9 <sup>Ⓞ</sup>	3 1/2"	2	278
ST 10 <sup>Ⓞ</sup>	4"	2	318
ST 11 <sup>Ⓞ</sup>	5"	1	478
ST 12 <sup>Ⓞ</sup>	6"	1	685

<sup>Ⓞ</sup>Optional nickel-chrome plate finish. Add suffix -CP.  
<sup>Ⓟ</sup>Not supplied with insulator.

## HUB BASIC SCRU-TITE® – NEMA 2, 3, 3R, 4, 4X, 12 Aluminum

UL File No. E-27258



Cat. #	Size	Unit qty.	Wt. lbs. per 100
STA 1	1/2"	25	8
STA 2	3/4"	25	11
STA 3	1"	25	17
STA 4	1 1/4"	10	30
STA 5	1 1/2"	10	30
STA 6	2"	10	38
STA 7	2 1/2"	5	80
STA 8	3"	2	100
STA 9	3 1/2"	2	138
STA 10	4"	2	150
STA 11 <sup>Ⓟ</sup>	5"	1	300
STA 12 <sup>Ⓟ</sup>	6"	1	300

<sup>Ⓟ</sup>Not supplied with insulator.

## GROUND HUB – NEMA 2, 3, 3R, 4, 4X, 12 316 Stainless steel

UL File No. E-59509



Cat. #	Size	Unit qty.	Wt. lbs. per 100
SSTG 1	1/2"	10	29
SSTG 2	3/4"	10	41
SSTG 3	1"	10	57
SSTG 4	1 1/4"	5	73
SSTG 5	1 1/2"	5	99
SSTG 6	2"	5	134
SSTG 7	2 1/2"	2	183
SSTG 8	3"	2	278
SSTG 9	3 1/2"	2	328
SSTG 10	4"	2	395

## GROUND HUB – NEMA 2, 3, 3R, 4, 4X, 12 Zinc

UL File No. E-59509



Cat. #	Size	Unit qty.	Wt. lbs. per 100	Max. Copper Grd. Wire Size	
				CSA <sup>Ⓞ</sup>	UL <sup>Ⓞ</sup>
STG 1	1/2"	25	20	#8	#8
STG 2	3/4"	25	28	#8	#8
STG 3	1"	25	42	#8	#8
STG 4	1 1/4"	10	55	#8	#8
STG 5	1 1/2"	10	70	#6	#8
STG 6	2"	10	95	#4	#8
STG 7	2 1/2"	5	190	#2	#6
STG 8	3"	2	243	1/0	#6
STG 9	3 1/2"	2	300	2/0	#6
STG 10	4"	2	323	2/0	#4
STG 11 <sup>Ⓟ</sup>	5"	1	625	2/0	#2
STG 12 <sup>Ⓟ</sup>	6"	1	750	3/0	#1

<sup>Ⓟ</sup>Not supplied with insulator.  
<sup>Ⓞ</sup>Use of wire terminal is required by CSA and recommended by UL for wire gauges over 10 AWG.

## GROUND HUB – NEMA 2, 3, 3R, 4, 4X, 12 Aluminum

UL File No. E-59509



Cat. #	Size	Unit qty.	Wt. lbs. per 100	Max. Copper Grd. Wire Size	
				CSA <sup>Ⓞ</sup>	UL <sup>Ⓞ</sup>
STAG 1	1/2"	25	13	#8	#8
STAG 2	3/4"	25	14	#8	#8
STAG 3	1"	25	18	#8	#8
STAG 4	1 1/4"	10	25	#8	#8
STAG 5	1 1/2"	10	33	#6	#8
STAG 6	2"	10	41	#4	#8
STAG 7	2 1/2"	5	90	#2	#6
STAG 8	3"	2	103	1/0	#6
STAG 9	3 1/2"	2	138	2/0	#6
STAG 10	4"	2	140	2/0	#4
STAG 11 <sup>Ⓟ</sup>	5"	1	325	3/0	#2
STAG 12 <sup>Ⓟ</sup>	6"	1	350	3/0	#1

<sup>Ⓟ</sup>Not supplied with insulator.  
<sup>Ⓞ</sup>Use of wire terminal is required by CSA and recommended by UL for wire gauges over 10 AWG.

## ATEX HAZARDOUS LOCATION HUB WITH INCREASED SAFETY GROUND TERMINAL

Zinc – NEMA 2, 3, 3R, 4, 4X; IP66



II 2 G Ex e IIC Gb Ta (-15°C to 120°C)

IECEX – Ex e IIC Gb Ta (-15°C to 120°C)

Class I, Zone 1, AEx e II

Class I, Zone 1, Ex e II

UL File No. E-59509



Cat. #	Size	Unit qty.	Wt. lbs. per 100	Max. Copper Grd. Wire Size	
				CSA®	UL®
STGK 1	1/2"	10	20	#8	#8
STGK 2	3/4"	10	31	#8	#8
STGK 3	1"	10	44	#8	#8
STGK 4	1 1/4"	5	60	#8	#8
STGK 5	1 1/2"	5	73	#6	#8
STGK 6	2"	5	99	#4	#8
STGK 7	2 1/2"	2	145	#2	#6
STGK 8	3"	2	243	1/0	#6
STGK 9	3 1/2"	2	304	2/0	#6
STGK 10	4"	2	327	2/0	#4

① Use of wire terminal is required by CSA and recommended by UL for wire gauges over 10 AWG.

## ATEX HAZARDOUS LOCATION HUB WITH INCREASED SAFETY GROUND TERMINAL

316 Stainless steel – NEMA 2, 3, 3R, 4, 4X; IP66



II 2 G Ex eb IIC Gb Ta (-55°C to 180°C)

IECEX – Ex eb IIC Gb Ta (-55°C to 180°C)

Class I, Zone 1, AEx e II

Class I, Zone 1, Ex e II

UL File No. E-187273



Cat. #	Size	Unit qty.	Wt. lbs. per 100	Max. Copper Grd. Wire Size	
				CSA®	UL®
SSTGK 1	1/2"	10	33	#8	#8
SSTGK 2	3/4"	10	44	#8	#8
SSTGK 3	1"	10	60	#8	#8
SSTGK 4	1 1/4"	5	76	#8	#8
SSTGK 5	1 1/2"	5	103	#6	#8
SSTGK 6	2"	5	137	#4	#8
SSTGK 7	2 1/2"	2	185	#2	#6
SSTGK 8	3"	2	281	1/0	#6
SSTGK 9	3 1/2"	2	331	2/0	#6
SSTGK 10	4"	2	399	2/0	#4

① Use of wire terminal is required by CSA and recommended by UL for wire gauges over 10 AWG.

## THROUGH-BULKHEAD FITTING – ZINC

UL File No. E-27258



Cat. #	Size	Unit qty.	Wt. lbs. per 100
STTB 1	1/2"	5	30
STTB 2	3/4"	5	50
STTB 3	1"	5	70
STTB 4	1 1/4"	5	85
STTB 5	1 1/2"	5	110
STTB 6	2"	5	152
STTB 7	2 1/2"	4	280
STTB 8	3"	2	408
STTB 9	3 1/2"	2	468
STTB 10	4"	2	533

## THROUGH-BULKHEAD FITTING – ALUMINUM

UL File No. E-27258



Cat. #	Size	Unit qty.	Wt. lbs. per 100
STTBA 1	1/2"	5	11
STTBA 2	3/4"	5	21
STTBA 3	1"	5	31
STTBA 4	1 1/4"	5	40
STTBA 5	1 1/2"	5	50
STTBA 6	2"	5	65
STTBA 7	2 1/2"	4	106
STTBA 8	3"	2	175

## THROUGH-BULKHEAD FITTING – ZINC WITHOUT NIPPLES

Packaged as two pieces unassembled

UL File No. E-27258



Cat. #	Size	Unit qty.	Wt. lbs. per 100
STTTB 1	1/2"	5	35
STTTB 2	3/4"	5	58
STTTB 3	1"	5	85
STTTB 4	1 1/4"	5	105
STTTB 5	1 1/2"	5	135
STTTB 6	2"	5	169

## THROUGH-BULKHEAD FITTING – ALUMINUM WITHOUT NIPPLES

Packaged as two pieces unassembled

UL File No. E-27258



Cat. #	Size	Unit qty.	Wt. lbs. per 100
STTTBA 1	1/2"	5	16
STTTBA 2	3/4"	5	25
STTTBA 3	1"	5	35
STTTBA 4	1 1/4"	5	40
STTTBA 5	1 1/2"	5	50
STTTBA 6	2"	5	75

Conduit hubs

## METRIC TO NPT ADAPTER – ZINC



Cat. #	Size	Unit qty.	Wt. lbs. per 100
STM 1	M20 - 1/2"	25	13
STM 2	M25 - 3/4"	25	19
STM 3	M32 - 1"	25	32
STM 4	M40 - 1 1/4"	10	40
STM 5	M50 - 1 1/2"	10	57
STM 6	M63 - 2"	10	70

**Note:** The Myers metric to NPT hub adapter is used to convert a threaded metric entry to an NPT entry. The female thread is NPT and the male thread is metric.

## METRIC TO NPT ADAPTER – 316 STAINLESS STEEL



Cat. #	Size	Unit qty.	Wt. lbs. per 100
SSTM 1	M20 - 1/2"	10	12
SSTM 2	M25 - 3/4"	10	27
SSTM 3	M32 - 1"	10	32
SSTM 4	M40 - 1 1/4"	5	46
SSTM 5	M50 - 1 1/2"	5	50
SSTM 6	M63 - 2"	5	99

**Note:** The Myers metric to NPT hub adapter is used to convert a threaded metric entry to an NPT entry. The female thread is NPT and the male thread is metric.

## NON-HAZARDOUS DRAIN PLUG – 316 STAINLESS STEEL

UL File No. E-23223

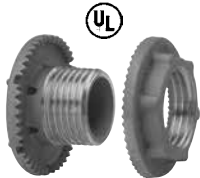

SSTC 1



SSTC 1CD

Cat. #	Size	Unit qty.	Wt. lbs. per 100
SSTC 1	1/2"	25	17
SSTC 1CD	1/2"	10	12

## NON-HAZARDOUS DRAIN PLUG – ALUMINUM

UL File No. E-23223

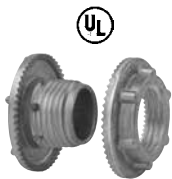

STAC 1ST



STAC 1CD

Cat. #	Size	Unit qty.	Wt. lbs. per 100
STAC 1ST	1/2"	25	6
STAC 1CD	1/2"	25	2

**Note:** SSTC 1 and STAC 1ST are for knockouts and are supplied with a locknut and straight threads. SSTC 1CD and STAC 1CD are for threaded openings and are supplied without locknut and NPT threads. Not gasketed to allow for water drainage.

## CAP-OFF – ZINC

UL File No. E-23223



Cat. #	Size	Unit qty.	Wt. lbs. per 100
STC 1⓪	1/2"	25	13
STC 2⓪	3/4"	25	19
STC 3⓪	1"	25	28
STC 4⓪⓪	1 1/4"	10	40
STC 5⓪⓪	1 1/2"	10	50
STC 6⓪⓪	2"	10	67

⓪ Optional nickel-chrome plate finish. Add suffix -CP.  
⓪ Not UL Listed.

## CAP-OFF – ALUMINUM

UL File No. E-23223



Cat. #	Size	Unit qty.	Wt. lbs. per 100
STAC 1	1/2"	25	5
STAC 2	3/4"	25	8
STAC 3	1"	25	12

## GROUND NUT – ZINC

UL File No. E-59509



Cat. #	Size	Unit qty.	Wt. lbs. per 100	Max. copper grd. wire size	
				CSA⓪	UL⓪
STGN 1	1/2"	25	6	#8	#8
STGN 2	3/4"	25	10	#8	#8
STGN 3	1"	25	13	#8	#8
STGN 4	1 1/4"	10	15	#8	#8
STGN 5	1 1/2"	10	23	#6	#8
STGN 6	2"	10	28	#4	#8

⓪ Use of wire terminal is required by CSA and recommended by UL for wire gauges over 10 AWG.

## GROUND NUT – ALUMINUM

UL File No. E-59509



Cat. #	Size	Unit qty.	Wt. lbs. per 100	Max. copper grd. wire size	
				CSA⓪	UL⓪
STAGN 1	1/2"	25	3	#8	#8
STAGN 2	3/4"	25	4	#8	#8
STAGN 3	1"	25	6	#8	#8
STAGN 4	1 1/4"	10	8	#8	#8
STAGN 5	1 1/2"	10	11	#6	#8
STAGN 6	2"	10	14	#4	#8

⓪ Use of wire terminal is required by CSA and recommended by UL for wire gauges over 10 AWG.

## Hub dimensions (in inches):

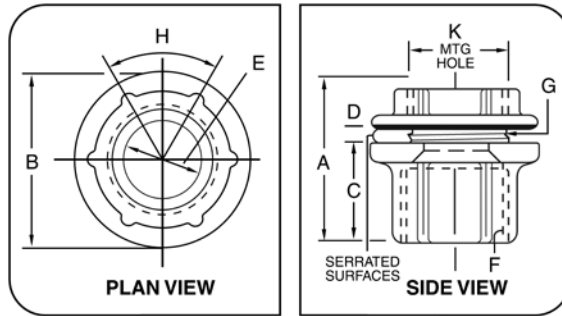

“D” dimension indicates maximum panel thickness which hub will accommodate.

Pipe size	A	B	C	D	E		F	G	H	K (mounting hole)	
					Min.	Max.				Min.	Max.
3/8	1 <sup>3</sup> / <sub>32</sub>	1 <sup>1</sup> / <sub>8</sub>	2 <sup>1</sup> / <sub>32</sub>	1 <sup>1</sup> / <sub>8</sub>	0.468	0.493	3/8 NPT	3/8 NPSM	60°	43/64	11/16
1/2	1 <sup>11</sup> / <sub>32</sub>	1 <sup>7</sup> / <sub>16</sub>	13/16	3/16	0.591	0.622	1/2 NPT	1/2 NPSM	60°	55/64	7/8
3/4	1 <sup>15</sup> / <sub>32</sub>	1 <sup>23</sup> / <sub>32</sub>	29/32	3/16	0.783	0.824	3/4 NPT	3/4 NPSM	60°	1 <sup>1</sup> / <sub>16</sub>	1 <sup>1</sup> / <sub>8</sub>
1	1 <sup>21</sup> / <sub>32</sub>	2	1 <sup>1</sup> / <sub>32</sub>	1/4	0.997	1.049	1 NPT	1 NPSM	60°	1 <sup>21</sup> / <sub>64</sub>	1 <sup>3</sup> / <sub>8</sub>
1 1/4	1 <sup>11</sup> / <sub>16</sub>	2 <sup>3</sup> / <sub>8</sub>	1 <sup>1</sup> / <sub>32</sub>	1/4	1.311	1.380	1 1/4 NPT	1 1/4 NPSM	60°	1 <sup>43</sup> / <sub>64</sub>	1 <sup>3</sup> / <sub>4</sub>
1 1/2	1 <sup>11</sup> / <sub>16</sub>	2 <sup>3</sup> / <sub>4</sub>	1 <sup>1</sup> / <sub>32</sub>	1/4	1.529	1.610	1 1/2 NPT	1 1/2 NPSM	60°	1 <sup>59</sup> / <sub>64</sub>	2
2	1 <sup>3</sup> / <sub>4</sub>	3 <sup>1</sup> / <sub>4</sub>	1 <sup>3</sup> / <sub>32</sub>	1/4	1.964	2.067	2 NPT	2 NPSM	60°	2 <sup>25</sup> / <sub>64</sub>	2 1/2
2 1/2	2 <sup>1</sup> / <sub>32</sub>	3 <sup>3</sup> / <sub>4</sub>	1 <sup>9</sup> / <sub>32</sub>	1/4	2.346	2.469	2 1/2 NPT	2 1/2 NPSM	60°	2 <sup>57</sup> / <sub>64</sub>	3
3	2 <sup>5</sup> / <sub>16</sub>	4 <sup>3</sup> / <sub>8</sub>	1 <sup>3</sup> / <sub>8</sub>	1/4	2.915	3.068	3 NPT	3 NPSM	45°	3 <sup>33</sup> / <sub>64</sub>	3 <sup>5</sup> / <sub>8</sub>
3 1/2	2 <sup>3</sup> / <sub>8</sub>	5	1 <sup>7</sup> / <sub>16</sub>	1/4	3.371	3.548	3 1/2 NPT	3 1/2 NPSM	45°	4 <sup>1</sup> / <sub>64</sub>	4 <sup>1</sup> / <sub>8</sub>
4	2 <sup>7</sup> / <sub>16</sub>	5 <sup>1</sup> / <sub>2</sub>	1 <sup>1</sup> / <sub>2</sub>	1/4	3.825	4.026	4 NPT	4 NPSM	45°	4 <sup>33</sup> / <sub>64</sub>	4 <sup>5</sup> / <sub>8</sub>
5	2 <sup>15</sup> / <sub>16</sub>	6 <sup>1</sup> / <sub>8</sub>	2	1/4	4.795	5.047	5 NPT	5 NPSM	45°	5 <sup>37</sup> / <sub>64</sub>	5 <sup>11</sup> / <sub>16</sub>
6	3	7 <sup>11</sup> / <sub>16</sub>	2	5/16	5.762	6.065	6 NPT	6 NPSM	45°	6 <sup>41</sup> / <sub>64</sub>	6 <sup>3</sup> / <sub>4</sub>

## Bulkhead dimensions (in inches):

Cat. #	Size	A	B	H	M	N
STTB 1						
STTB A 1	1/2	1.465	1.429	60°	1/2 - 14 NPSM	1/2 - 14 NPT
STTTB 1						
STTTBA 1						
STTB 2						
STTB A 2	3/4	1.652	1.677	60°	3/4 - 14 NPSM	3/4 - 14 NPT
STTTB 2						
STTTBA 2						
STTB 3						
STTB A 3	1	1.801	1.998	60°	1 - 11 1/2 NPSM	1 - 11 1/2 NPT
STTTB 3						
STTTBA 3						
STTB 4						
STTB A 4	1 1/4	1.711	2.373	60°	1 1/4 - 11 1/2 NPSM	1 1/4 - 11 1/2 NPT
STTTB 4						
STTTBA 4						
STTB 5						
STTB A 5	1 1/2	1.717	2.741	60°	1 1/2 - 11 1/2 NPSM	1 1/2 - 11 1/2 NPT
STTTB 5						
STTTBA 5						
STTB 6						
STTB A 6	2	1.755	3.230	60°	2 - 11 1/2 NPSM	2 - 11 1/2 NPT
STTTB 6						
STTTBA 6						
STTB 7						
STTB A 7	2 1/2	2.500	3.747	45°	2 1/2 - 8 NPSM	2 1/2 - 8 NPT
STTB 8						
STTB A 8	3	2.500	4.392	45°	3 - 8 NPSM	3 - 8 NPT
STTB 9						
STTB A 9	3 1/2	2.290	4.975	45°	3 1/2 - 8 NPSM	3 1/2 - 8 NPT
STTB 10						
STTB A 10	4	2.439	5.516	45°	4 - 8 NPSM	4 - 8 NPT

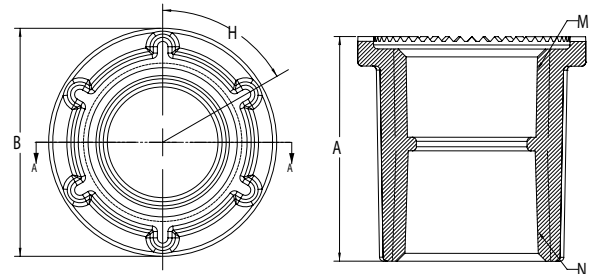

## Spacing chart: Conduit or pipe size

Cond. size	1/4	3/8	1/2	3/4	1	1 1/4	1 1/2	2	2 1/2	3	3 1/2	4	5	6
3/8	1 5/32	1 1/4												
1/2	1 5/16	1 13/32	1 9/16											
3/4	1 7/16	1 17/32	1 11/16	1 13/16										
1	1 9/32	1 11/16	1 27/32	1 31/32	2 1/8									
1 1/4	1 25/32	1 7/8	2 1/32	2 5/32	2 5/16	2 1/2								
1 1/2	1 31/32	2 1/16	2 1/32	2 11/32	2 1/2	2 11/16	2 7/8							
2	2 1/32	2 5/16	2 15/32	2 19/32	2 3/4	2 15/16	3 1/8	3 3/8						
2 1/2	2 15/32	2 9/16	2 23/32	2 27/32	3	3 3/16	3 3/8	3 5/8	3 7/8					
3	2 25/32	2 7/8	3 1/32	3 5/32	3 5/16	3 1/2	3 11/16	3 15/16	4 3/16	4 1/2				
3 1/2	3 3/32	3 3/16	3 11/32	3 15/32	3 5/8	3 13/16	4	4 1/4	4 1/2	4 13/16	5 1/8			
4	3 11/32	3 7/16	3 19/32	3 23/32	3 7/8	4 1/16	4 1/4	4 1/2	4 3/4	5 1/16	5 5/8	5 3/4		
5	4 1/32	4 3/8	4 3/32	4 13/32	4 9/16	4 3/4	4 15/16	5 3/16	5 1/16	5 5/4	6 1/16	6 3/16	7 1/8	
6	4 13/32	4 1/2	4 21/32	4 25/32	4 15/16	5 1/8	5 5/16	5 9/16	5 13/16	6 1/8	6 1/16	6 11/16	7 3/8	7 3/4

Minimum space from center of pipe or conduit to nearest obstruction.

1. Dimensions in top row (boxed squares) are centers for conduits of same size.

Example: How close may 3" conduits be spaced? Answer 4 1/2".

2. Dimensions in gray shaded squares are for centers of conduits NOT of the same size.

Example: What is the minimum spacing for 2" and 3/4" conduit?

Read down column marked 3/4" to figure opposite 2" and find dimension is 2 9/32".

Note: Minimum spacing dimensions as shown will give approximately 1/16" clearance between locking nuts.

Conduit hubs

### Minimum space from center of pipe or conduit to nearest obstruction

	19/32	11/16	27/32	31/32	1 1/8	1 5/16	1 1/2	1 3/4	2	2 5/16	2 5/8	2 7/8	3 8/16	3 15/16
--	-------	-------	-------	-------	-------	--------	-------	-------	---	--------	-------	-------	--------	---------