

SPECIFICATION	CONNECTION	
	UNIPOLAR OR BIPOLAR-1 WINDING	BIPOLAR SERIAL
VOLTAGE (VDC)	3.23	4.56
AMPS/PHASE	0.95	0.67
RESISTANCE/PHASE (Ohms)@25°C	3.4±15%	6.8±15%
INDUCTANCE/PHASE (mH) @1KHz	1.2±20%	4.8±20%
HOLDING TORQUE (Nm) [lb-in]	0.075 [0.664]	0.106 [0.938]
DETENT TORQUE (Nm) [lb-in]	3.75x10 ⁻³ [0.0332]	
STEP ANGLE (°)	1.8	
STEP ACCURACY (NON-ACCUM)	±5%	
ROTOR INERTIA (Kg-m ²) [lb-in ²]	12x10 ⁻⁷ [4.1x10 ⁻³]	
WEIGHT (Kg) [lb]	0.176 [0.388]	
TEMPERATURE RISE: MAX.80°C (MOTOR STANDSTILL; FOR 2 PHASE ENERGIZED)		
AMBIENT TEMPERATURE -10°~ 50°C [14°F ~ 122°F]		
INSULATION RESISTANCE 100 MOhm (UNDER NORMAL TEMPERATURE AND HUMIDITY)		
INSULATION CLASS B 130° [266°F]		
DIELECTRIC STRENGTH 500VAC FOR 1 MIN. (BETWEEN THE MOTOR COILS AND THE MOTOR CASE)		
AMBIENT HUMIDITY MAX. 85% (NO CONDENSATION)		

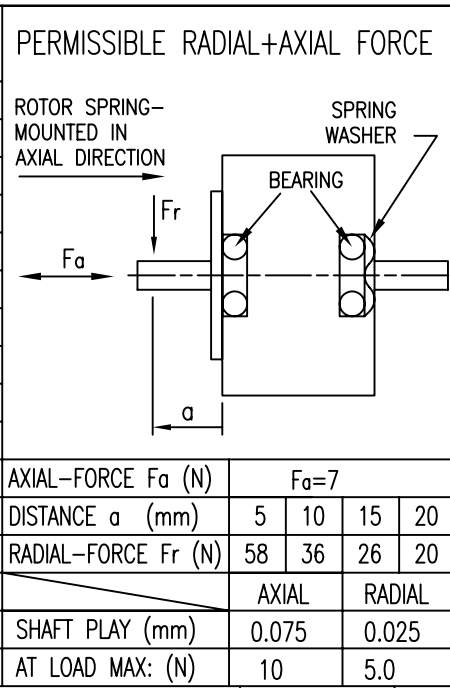

TYPE OF CONNECTION (EXTERN)			MOTOR		
UNIPOLAR	BIPOLAR		CONNECTOR PIN NO.	LEADS	WINDING
	1WINDING	SERIAL			
A ---	A ---	A ---	1	BLK	A
COM ---	COM ---	COM ---	5	YEL	
A\ ---	A\ ---	A\ ---	3	GRN	A\
B ---	B ---	B ---	2	RED	B
COM ---	COM ---	COM ---	6	WHT	
B\ ---	B\ ---	B\ ---	4	BLU	B\

for >speed ←---┐
 for <speed ←---┘

FULL STEP 2 PHASE-Ex., WHEN FACING MOUNTING END (X)

STEP	A	B	A\	B\	CCW	CW
1	+	+	-	-	↓	↑
2	-	+	+	-	↓	↑
3	-	-	+	+	↓	↑
4	+	-	-	+	↓	↑

WIRING DIAGRAM

NANOTEC:				SCALE FREE	APVD	S.K.	06.06.06	STEPPING MOTOR
ST2818M1006-B				X ±0.5	CHKD			
				1PL ±0.2	DRN	J.W.	06.06.06	DWG.NO
REV	DESCRIPTION	DATE	APVD	2PL ±0.1	SIGNATURE		DATE	ST2818M1006-B
				ANGLE ±30'				