

MOSFET BASED DC SOLID STATE RELAY

- ▶ Latest MOSFET technology generation.
- ▶ Ultra low on-state resistance.
- ▶ New innovative isolated driver ensuring fast power transistor turn on and off therefore low power transient.
- ▶ Ultra low output leakage current
- ▶ Low control current consumption
- ▶ Triggered control input to avoid linear control risks
- ▶ Low conducted and radiated disturbances



SCM030200



Control voltage range	4.5-32VDC
Max. output peak voltage	200VDC
Nom. load current with heatsink	30ADC

Load voltage range	Load current range	Control input voltage range	In & case / Out Insulation	Connections	Dimensions (WxHxD)	Weight
Depends on protection clamping voltage	0 to 30A (with heatsink)	4.5-32VDC	4kV	M3 round tabs M5 round tabs	44.5 x 58.2 x 27 (mm)	100g

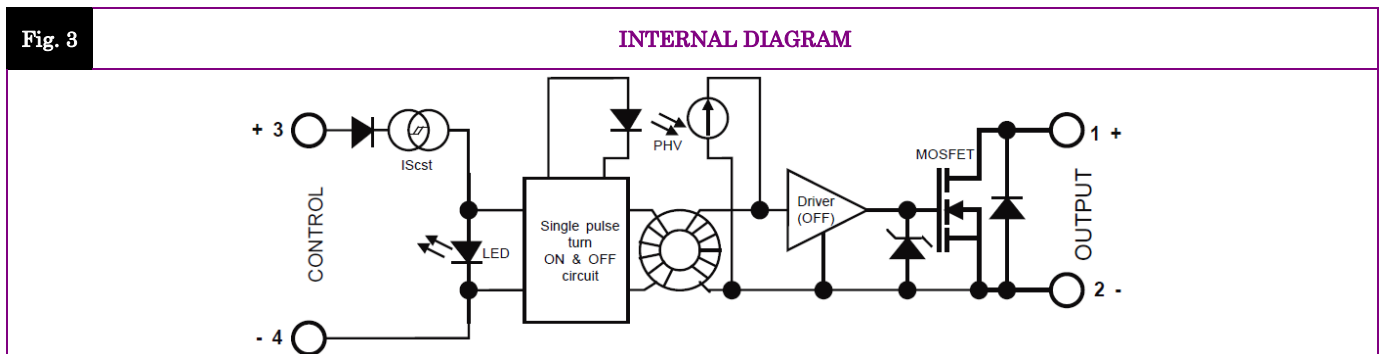
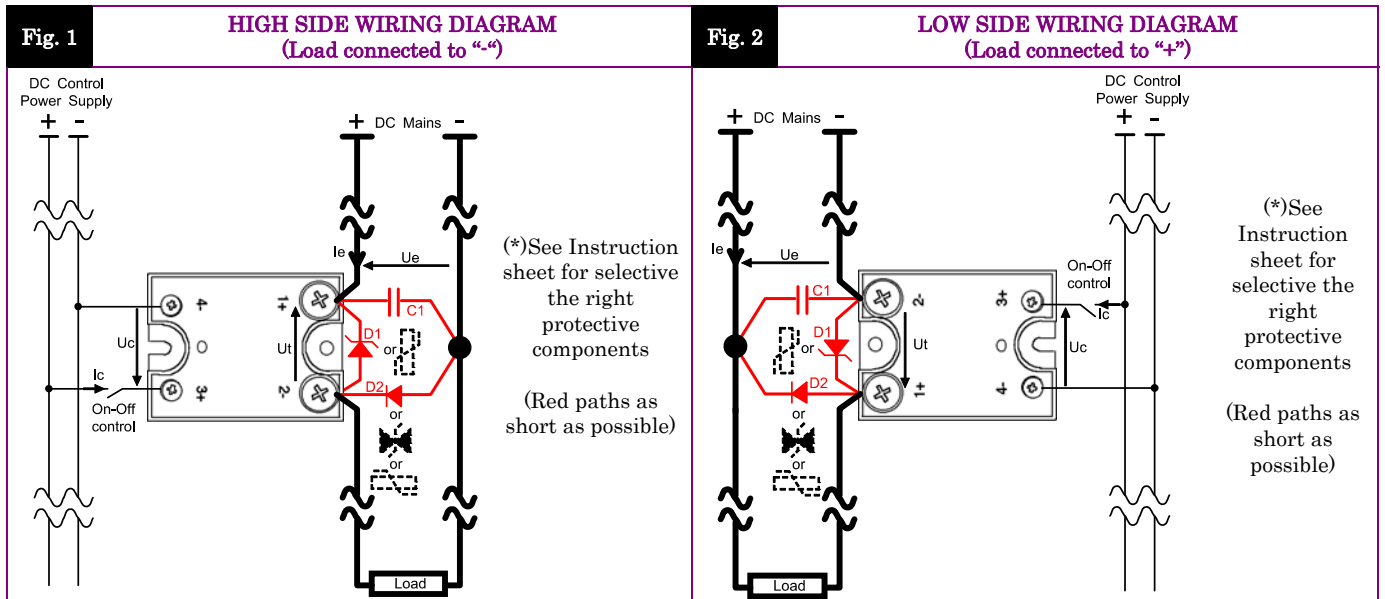

Proud to serve you

CONTROL INPUT CHARACTERISTICS

INPUT CIRCUIT	CHARACTERISTIC	LABEL	VALUE	INFO.
	Control voltage range	Uc	4.5 – 32VDC	
	Current consumption	Ic	25 – 42mADC for control voltage range	See fig. 5
	Typical turn on voltage	Ucontyp	4.3V	
	Min. releasing voltage	Ucoffmin	1VDC	
	Typical releasing voltage	Ucofftyp	3.5V	
	Max. input voltage	Ucmax	32VDC	
	Max. reverse voltage	-Ucmax	32VDC	
	Max. reverse leakage current	-Icmax	100µA	
	Input impedance	Re	Current limitation	See fig. 5

POWER OUTPUT CHARACTERISTICS

POWER CIRCUIT	CHARACTERISTIC	LABEL	VALUE	INFO.	
	Mains voltage range	Ue	Depends on protection clamping voltage		
	Non-repetitive peak voltage	Utp	200V		
	Overvoltage protection	D1	Not integrated A voltage clamping mean must be connected across the terminals 1 & 2 (see fig 1 & 2)	See Instruction sheet for selective the right protective components	
	Reverse voltage (internal diode)	-Ut	1,5V	@Ie=-30A @Uc=0	
	Max. repetitive avalanche current	Iep	18A	Pulse width limited by Tj max	
	Max. single pulse avalanche energy	Eep	315mJ	@Ut=50V @Ie=Iep	
	Max. repetitive pulse avalanche energy	Eep	20mJ	@Ie=30A	
	Maximum nominal currents	Ie	Resistive	Motor	See fig. 7 for limits Values with heatsink
			30A	Please consult us	
	Non-repetitive peak overload current	Iepeak	120A @Ut=7VDC during 1ms		See fig. 8
	Min. load current	Iemin	0mA		
	Max. leakage current	Ielk	100µADC		@Utp @Tjmax
	Max. on-state resistance	RDson	164mΩ		@Iemax @Tjmax
	Typ. output capacitance	Cout	3nF (Ut=1V 1MHz)		Uc=0
	Junction/case thermal resistance per power element	Rthjc	0.75K/W		Total = 1 power element
	Built-in heatsink thermal resistance vertically mounted	Rthra	8K/W		@ΔTra=60°C
	Heatsink thermal time constant	Tthra	10min		@ΔTra=60°C
	Control inputs/power outputs insulation voltage	Uimp	4kV		
	Inputs/case insulation voltage	Uimp	4kV		
	Outputs/case insulation voltage	Uimp	4kV		
	Isolation resistance	Rio	1GΩ		
	Isolation capacitance	Cio	<8pF		
	Maximum junction temperature	Tjmax	175°C		
	Storage ambient temperature	Tstg	-40->+100°C		
	Operating ambient temperature	Tamb	-40->+90°C		See fig. 7
	Max. case temperature	Tc	100°C		

TIME CHARACTERISTICS

Fig. 4

TIME DIAGRAMS

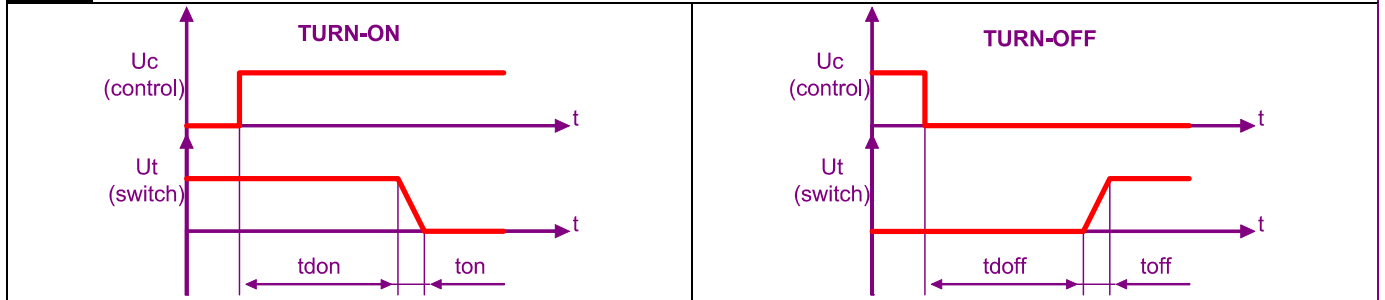

TIME CHARACT.	CHARACTERISTIC	LABEL	VALUE	INFO.
	Turn on time	ton	10µs (1.2µs typical)	
	Turn on delay	tdon	600µs (500µs typical)	
	Turn off time	toff	10µs (1µs typical)	
	Turn off delay	tdoff	100µs (60µs typical)	
	Max. On-Off frequency	F(on-off)	700Hz	

GENERAL INFORMATION

CONNECTIONS	Connections	Power	Control	
	Screwdriver advised	Philips™ NR2	Philips™ NR1	
	Min and max tightening torque	1.8 N.m	0.8 N.m	
	Insulated crimp terminals (round tabs, eyelet type)	M5	M3	

MISC.	Display	Green LED (indicates relay has switched ON)	
	Housing	UL94V0	
	Mounting	2 screws (M4x12mm)	See mounting sheet
	Noise level	No audible noise	
	Weight	100g	

STANDARDS

GENERAL	Standards	IEC60947-1	
	Protection level	IP00	
	Protection against direct touch	None	
	CE marking	Yes	
	UL, cULUS	Yes	

E.M.C. IMMUNITY	TYPE OF TEST	STANDARD	LEVEL	EFFECT
	E.S.D. (Electrostatic discharges)	EN61000-4-2	Pending	
	Radiated electromagnetic fields	EN61000-4-3	Pending	
	Fast transients bursts	EN61000-4-4	4kV coupling by clamp on the input side (power side to be tested)	No effect
	Electric chocks	EN61000-4-5	1kV direct coupling on control side (pending on power side)	No effect
Voltage drop	EN61000-4-11	-		

E.M.C. EMISSION	Radiated and conducted disturbances	NFEN55011	Pending	
-----------------	-------------------------------------	-----------	---------	--

CHARACTERISTIC CURVES

Fig. 5

INPUT CHARACTERISTIC

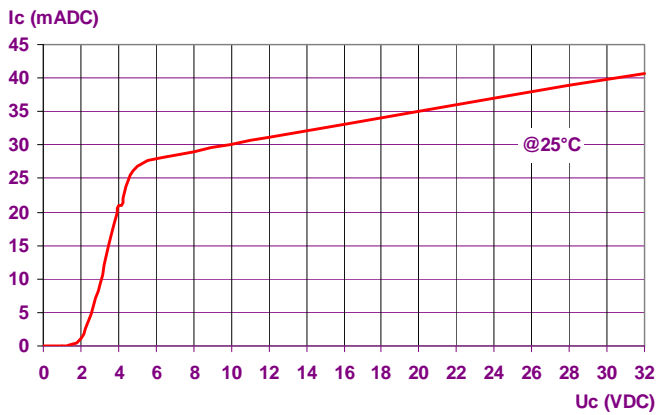

Fig. 6

ON RESISTANCE VS TEMPERATURE

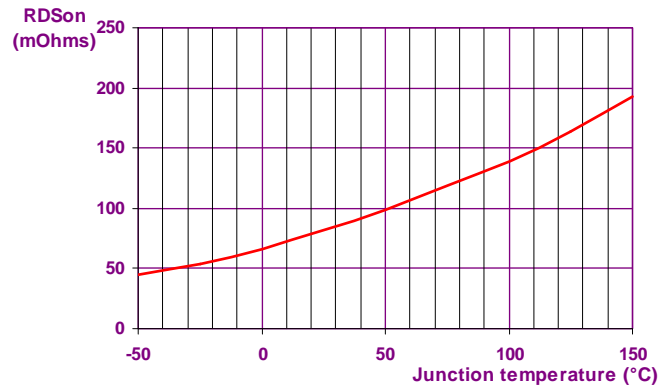

Fig. 7

POWER DISSIPATED AND LOAD CURRENT LIMIT VS TEMPERATURE

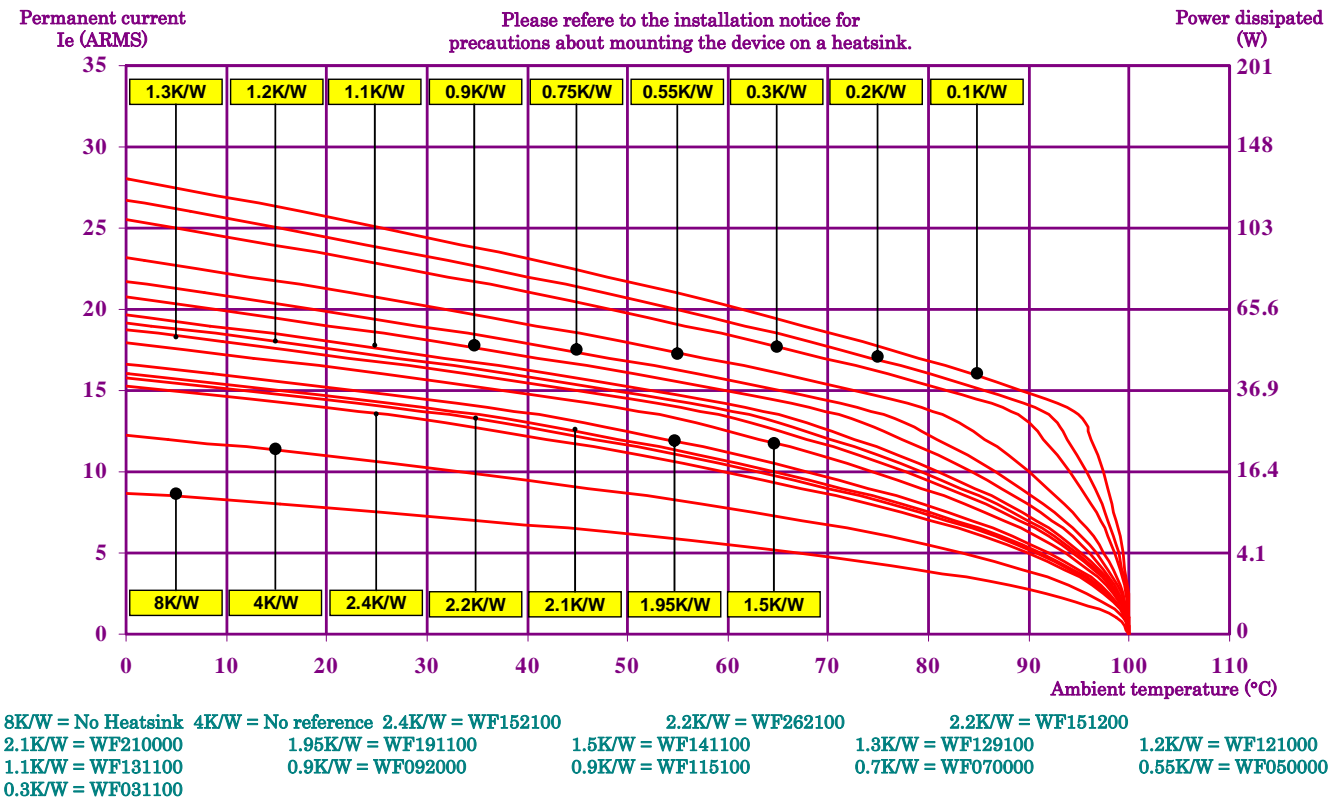
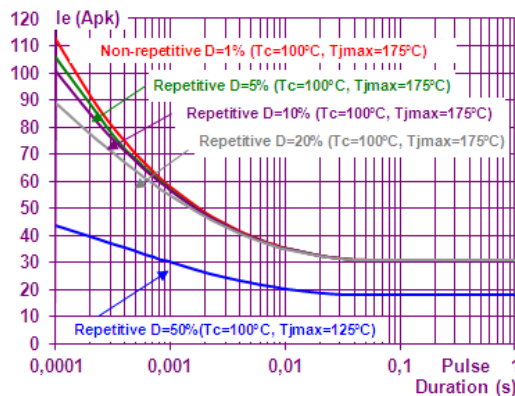

Fig. 8

CURRENT OVERLOAD CHARACTERISTIC



DIMENSIONS AND ACCESSORIES

Fig. 9

DIMENSIONS

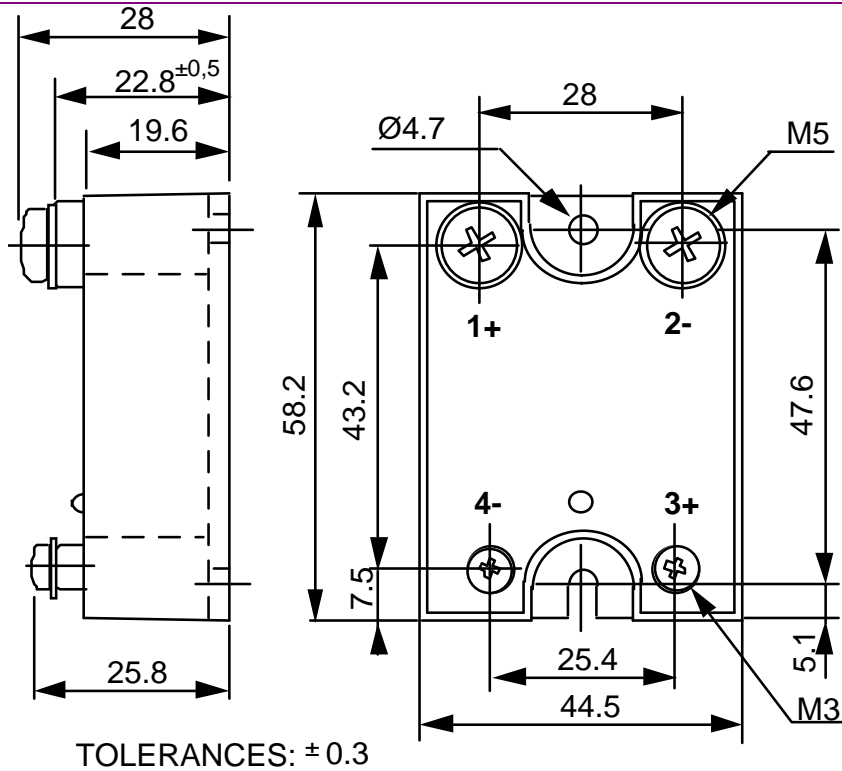
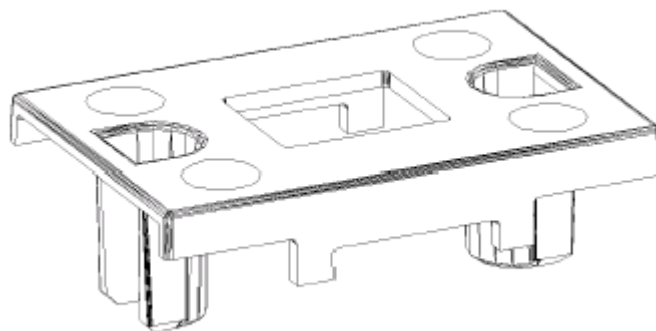

Fig. 10

ACCESSORIES



PROTECTIVE COVER 1K470000