

REVISIONS			
LTR	DESCRIPTION	DATE	APPROVED
A	REVISED PER DCR NO. R020546	AUG 02	KJW

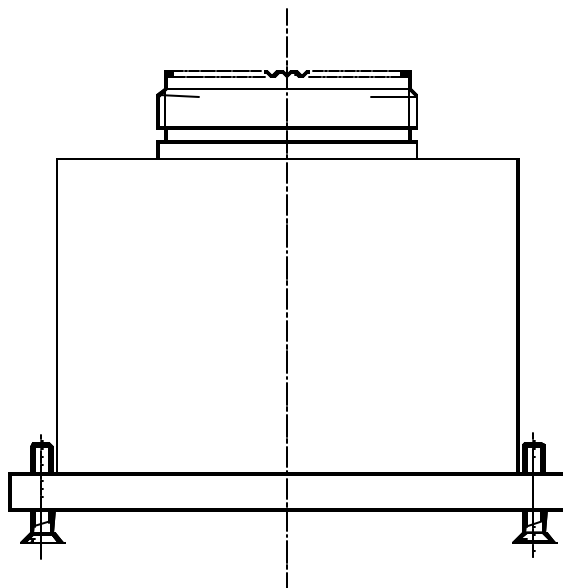

ADAPTER FOR MIL-C-81659 CONNECTOR

NOTES

1. THIS PRODUCT IS DESIGNED TO TERMINATE A TYCO CODE 40 0/NO. 24 ADAPTER (AND A HEAT SHRINKABLE LIPPED BOOT IF REQUIRED) TO A CONNECTOR - SEE NOTE 4.
2. SEE SHEET 2 FOR DIMENSIONS AND PART NUMBERING/ORDERING SYSTEM.
3. ADAPTER TO BE PERMANENTLY MARKED WITH CODE IDENTIFICATION NUMBER AND FULL PART NUMBER. (e.g. 06090-SCA404 02B4024-19B).
- ④ ADAPTER MATES TO: MIL-C-81659 - DUAL INSERT CONNECTORS.
5. FOR ALTERNATIVE MATERIALS AND PLATING FINISHES CONTACT TYCO/RAYCHEM.

**If this document is printed it becomes uncontrolled.
Check with the web for latest revision.**

SPECIFICATION CONTROL DRAWING

UNLESS OTHERWISE SPECIFIED
DIMENSIONS ARE IN INCHES.
METRIC DIMENSIONS ARE
IN BRACKETS.

DECIMALS

.X ± 0.030 [0.76]

.XX ± 0.010 [0.25]

.XXX ± 0.005 [0.13]

ANGLES

.X ± ---

DRAWN	DATE
IRT	AUG 02
CHECKED	DATE
KJW	AUG 02
APPROVED	DATE
KJW	AUG 02
APPROVED	DATE
KJW	AUG 02
CAD NAME	
85148	

tyco/Electronics **Raychem**

TITLE
ADAPTER FOR MIL-C-81659 CONNECTOR
TO MIL-C-38999/III AND IV 0/NO 24

THIRD ANGLE
PROJECTION

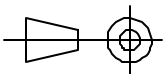

SIZE	CODE IDENT. NO.	DWG NO.	REV
A4	06090	SCA404 02B4024	A

If this document is printed it becomes uncontrolled.
Check with the web for latest revision.

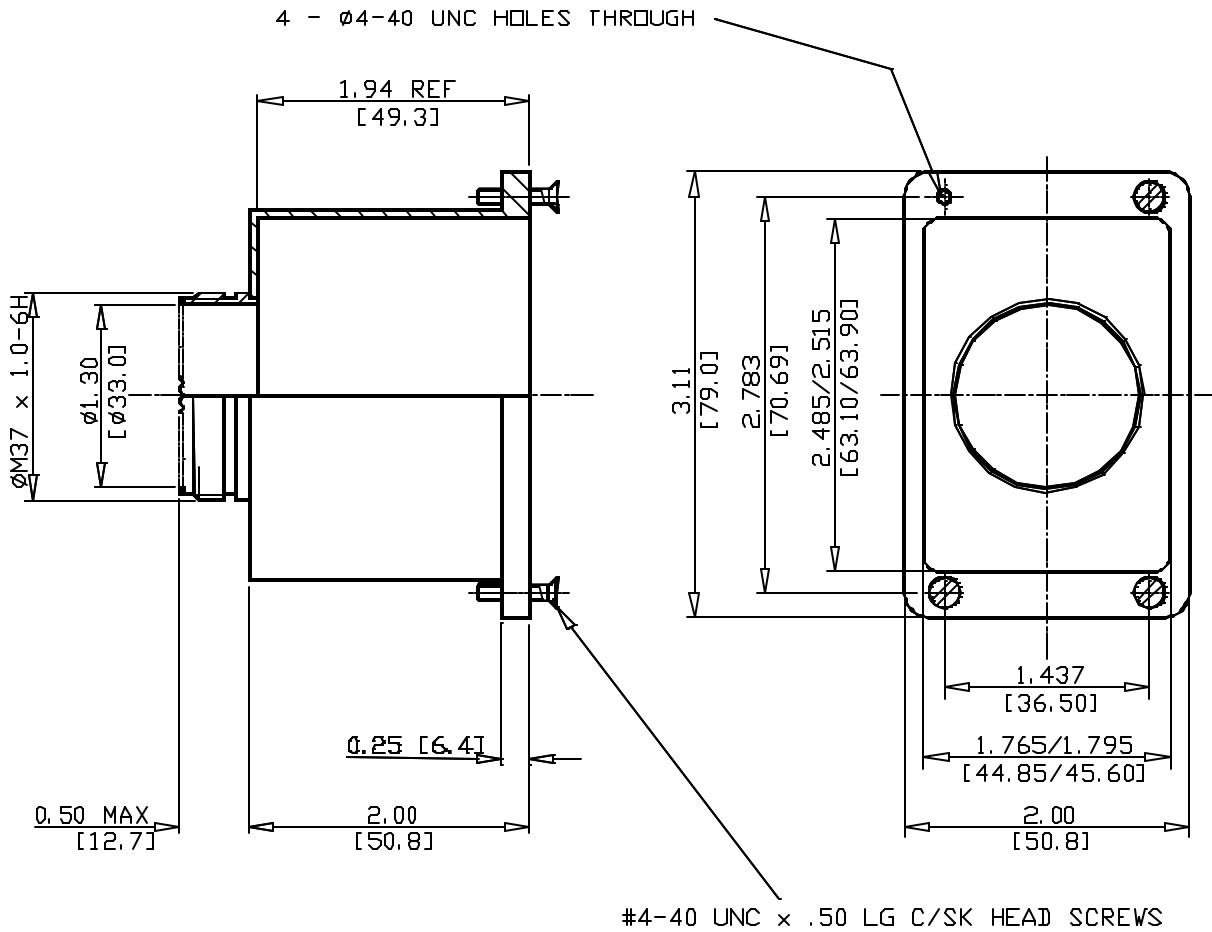

PART NUMBERING SYSTEM

SCA 404 02B 4024-19 B

PREFIX

④ SEQUENTIAL NUMBER = MIL-C-81659

④ ORDER NUMBER = DUAL INSERT- PANEL LOCATION

OUTLET NUMBER = MATES WITH CODE 40 □/NO. 24

MATERIAL

19 = ALUMINIUM ALLOY
(HARDWARE S/ST PASSIVATED)

FINISH (SEE S-CH00-0157-002)

B = CADMIUM PLATE, OLIVE DRAB
C = ELECTROLESS NICKEL
H = CADMIUM PLATE, GOLD

SIZE	CODE IDENT. NO.	DWG. NO.	REV
A4	06090	SCA404 02B4024	A
DO NOT SCALE THIS DWG			SHEET 2 OF 2