

20 W Power Resistors, Thick Film Technology, TO-220

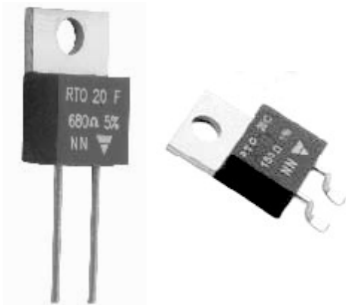

The well known TO-220 package is compact and easy to mount.

DIMENSIONS in millimeters

RTO 20F - LEADED

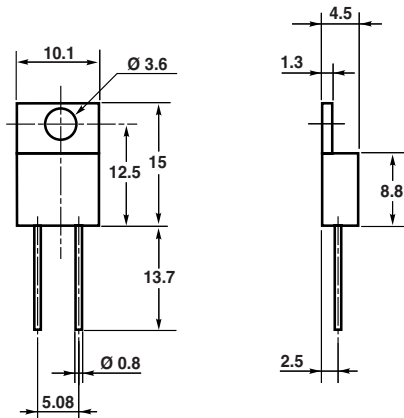

RTO 20C - FOR SURFACE MOUNTING

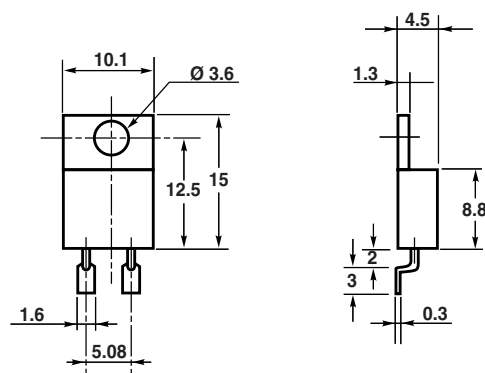

• Tolerance unless otherwise specified: ± 0.4 mm

• Only for RTO 20 version C = during surface mount soldering temperature profile must not cause the metal tab of this device to exceed 220 °C.

MECHANICAL SPECIFICATIONS

Mechanical Protection	Insulated case
Resistive Element	Thick Film
Connections	Tinned copper
Weight	2.2 g max.

DIMENSIONS

Standard Package	TO-220 Insulated case
-------------------------	--------------------------

ENVIRONMENTAL SPECIFICATIONS

Temperature Range	- 55 °C to + 155 °C
Climatic Category	55/155/56
Sealing	Sealed container Solder immersion
Flammability	IEC 60695-11-5 2 applications 30 s separated by 60 s

ELECTRICAL SPECIFICATIONS	
Resistance Range	0.010 Ω to 550 kΩ serie E24
Tolerances (Standard)	± 1 % to ± 10 %
Dissipation and Associated:	Onto a heatsink
Thermal Resistance and Nominal Power	20 W at + 25 °C R _{TH (j-c)} : 6.5 °C/W free air: 2 W at + 25 °C
Temperature Coefficient Standard (- 55 °C; + 150 °C)	See Performance table ± 150 ppm/°C
Limiting Element Voltage U_L	250 V
Dielectric Strength MIL STD 202	2000 V _{RMS} - 1 min - 10 mA max. (between terminals and heatsink)
Insulation Resistance	≥ 10 ⁶ MΩ
Inductance	≤ 0.1 μH
Critical Resistance	3.12 kΩ

FEATURES

- 20 W at 25 °C heatsink mounted
- High power dissipation to size ratio
- Wide resistance range from 0.01 Ω to 550 kΩ
- Negligible inductance
- Easy mounting
- TO-220 package: Compact and easy to mount
- Compliant to RoHS directive 2002/95/EC



Two versions of this thick film resistor are available:

- A radial leaded version for PCB mounting
- A flat lead version for surface mounting

Not compatible with RoHS reflow profile.

PERFORMANCE		
TESTS	CONDITIONS	REQUIREMENTS
Momentary Overload	EN 60115-1 2 Pr 5 s for R < 2 Ω 1.6 Pr 5 s for R ≥ 2 Ω Us < 1.5 UL	± (0.25 % + 0.005 Ω)
Rapid Temperature Change	EN 60115-1/60068-2-14 5 cycles - 55 °C to + 155 °C	± (0.5 % + 0.005 Ω)
Load Life	EN 60115-1 1000 h Pr at + 25 °C	± (1 % + 0.005 Ω)
Humidity (Steady State)	EN 60115-1 56 days R.H. 95 %	± (0.5 % + 0.005 Ω)
High Temperature Exposure	NF EN 140 000 1000 h - 40 % Pr at + 100 °C	± (0.5 % + 0.005 Ω)
Vibration	MIL STD 202, Method 204 C Test D	± (0.2 % + 0.005 Ω)
Terminal Strength	MIL STD 202, Method 211 Test A1	± (0.2 % + 0.005 Ω)
Shock	IEC 60115-1 IEC 60068-2-27 Saw tooth: 100 g/6 ms	± (0.5 % + 0.005 Ω)

SPECIAL FEATURES				
Resistance Values	≥ 0.01	≥ 0.015	≥ 0.1	≥ 0.5
Tolerances	± 1 % at ± 10 %			
Typical Temperature Coefficient Range (- 55 °C to + 155 °C)	± 900 ppm/°C	± 700 ppm/°C	± 250 ppm/°C	± 150 ppm/°C

Note

- For very low ohmic values, TCR for information

CHOICE OF THE HEATSINK

The user must choose according to the working conditions of the component (power, room temperature).

Maximum working temperature must not exceed 155 °C. The dissipated power is simply calculated by the following ratio:

$$P = \frac{\Delta T}{[R_{TH(j-c)} + R_{TH(c-a)}]} \quad (1)$$

P: Expressed in W

ΔT: Difference between maximum working temperature and room temperature

R_{TH(j-c)}: Thermal resistance value measured between resistive layer and outer side of the resistor. It is the thermal resistance of the component: (Special Features table)

R_{TH(c-a)}: Thermal resistance value measured between outer side of the resistor and room temperature. It is the thermal resistance of the heatsink itself (type, shape) and the quality of the fastening device.

Example:

R_{TH(c-a)}: For RTO 20 power rating 10 W at ambient temperature + 25 °C

Thermal resistance R_{TH(j-c)}: 6.5 °C/W

Considering equation (1) we have:

$$\Delta T = 155 \text{ °C} - 25 \text{ °C} = 130 \text{ °C}$$

$$R_{TH(j-c)} + R_{TH(c-a)} = \frac{\Delta T}{P} = \frac{130}{10} = 13 \text{ °C/W}$$

$$R_{TH(c-a)} = 13 \text{ °C/W} - 6.5 \text{ °C/W} = 6.5 \text{ °C/W}$$

OVERLOADS

In any case the applied voltage must be lower than the maximum overload voltage of 375 V.

The values indicated on the graph below are applicable to resistors in air or mounted onto a heatsink.

ENERGY CURVE

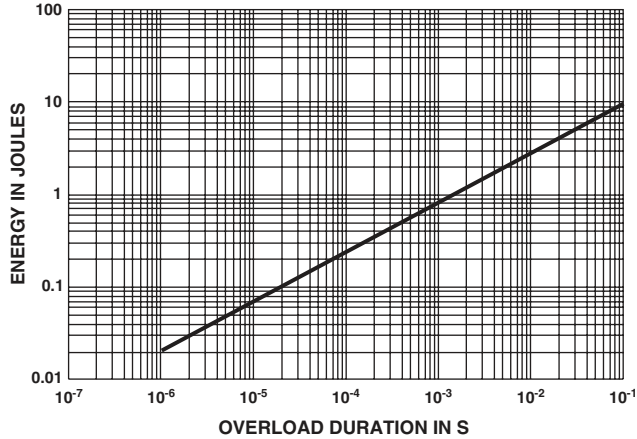

POWER RATING CHART

The temperature of the heatsink should be maintained within the limits specified.

To improve the thermal conductivity, surfaces in contact should be coated with a silicone grease and the torque applied on the screw for tightening should be around 1 Nm. Spring clip can also be used to mount the component on an heatsink (ex: Kunze, clip KU4-498).

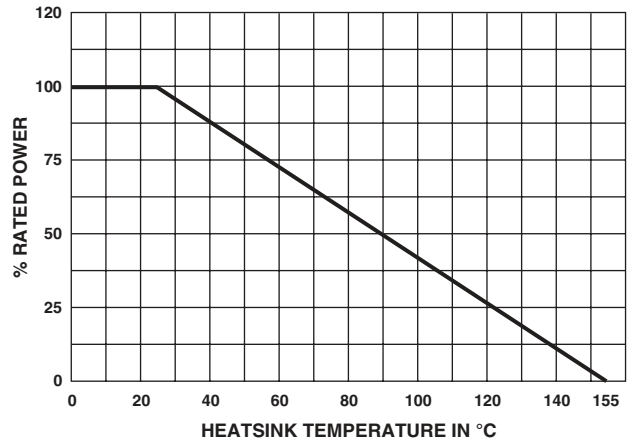

MARKING

Model, style, resistance value (in Ω), tolerance (in %), manufacturing date, VISHAY trademark.

PACKAGING

Tube of 50 units

ORDERING INFORMATION

RTO	20	F	U68	5 %	xxx	TU50	e3
MODEL	STYLE	CONNECTIONS	RESISTANCE VALUE	TOLERANCE	CUSTOM DESIGN	PACKAGING	LEAD (Pb)-FREE
	F: Radial leads C: Surface mount			± 1 % ± 2 % ± 5 % ± 10 %	Optional on request: Special TCR, shape etc.		

GLOBAL PART NUMBER INFORMATION

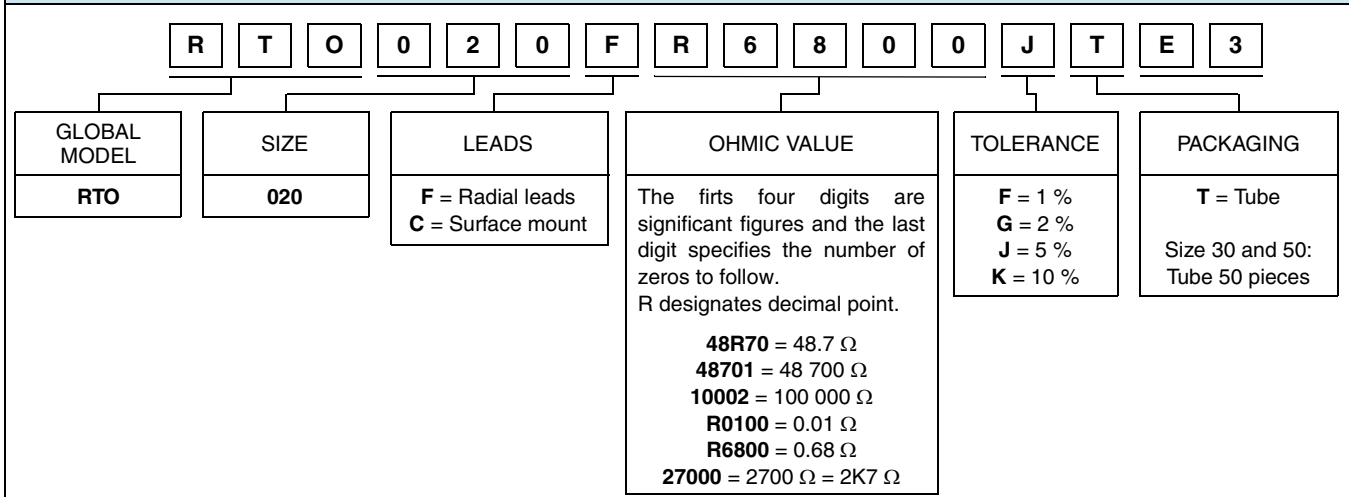



Disclaimer

All product specifications and data are subject to change without notice.

Vishay Intertechnology, Inc., its affiliates, agents, and employees, and all persons acting on its or their behalf (collectively, "Vishay"), disclaim any and all liability for any errors, inaccuracies or incompleteness contained herein or in any other disclosure relating to any product.

Vishay disclaims any and all liability arising out of the use or application of any product described herein or of any information provided herein to the maximum extent permitted by law. The product specifications do not expand or otherwise modify Vishay's terms and conditions of purchase, including but not limited to the warranty expressed therein, which apply to these products.

No license, express or implied, by estoppel or otherwise, to any intellectual property rights is granted by this document or by any conduct of Vishay.

The products shown herein are not designed for use in medical, life-saving, or life-sustaining applications unless otherwise expressly indicated. Customers using or selling Vishay products not expressly indicated for use in such applications do so entirely at their own risk and agree to fully indemnify Vishay for any damages arising or resulting from such use or sale. Please contact authorized Vishay personnel to obtain written terms and conditions regarding products designed for such applications.

Product names and markings noted herein may be trademarks of their respective owners.