

1 Description

The RedRock™ RR122-1A22-511 / 512 is a digital magnetic sensor ideal for use in medical, industrial, automotive, and consumer applications. It is based on patented Tunneling Magnetoresistance (TMR) technology with seamless CMOS integration.

The RR122-1A22-511 / 512 features an operate sensitivity of 9 G (0.9 mT), with an omnipolar magnetic field response. It offers a wide supply voltage range from 1.7 up to 5.5 V, ideal for applications ranging from small battery-powered electronics to industrial machinery. It has the world's lowest average current drain (190 nA) for an active magnetic sensor, as well an operating frequency of 10 Hz and high operating temperature ranges from -40°C up to +85°C.

Device Information

Part Series	Package	Body Size (mm)
RR122-1A22-511	SOT-23-3	2.90 x 1.60 x 1.02
RR122-1A22-512	LGA-4	1.45 x 1.45 x 0.44

Device Packages



2 Features

- ▶ Operate sensitivity of 9 G
- ▶ Lowest Average Current < 120 nA
- ▶ Wide Supply Voltage range of 1.7V – 5.5V
- ▶ Omnipolar Push-Pull Response
- ▶ Operating Frequency of 10 Hz
- ▶ Temperature Rated up to 85°C
- ▶ RoHS & REACH Compliant

3 Applications

- ▶ Proximity Detection
- ▶ Rotary Sensing
- ▶ Fluid Level Detection
- ▶ Door & Lid Closure Detection
- ▶ Utility Meters
- ▶ Portable Medical Devices
- ▶ Motor Controllers
- ▶ Consumer Electronics
- ▶ Wake-Up μ Processor

Functional Block Diagram for Digital Push-Pull Output

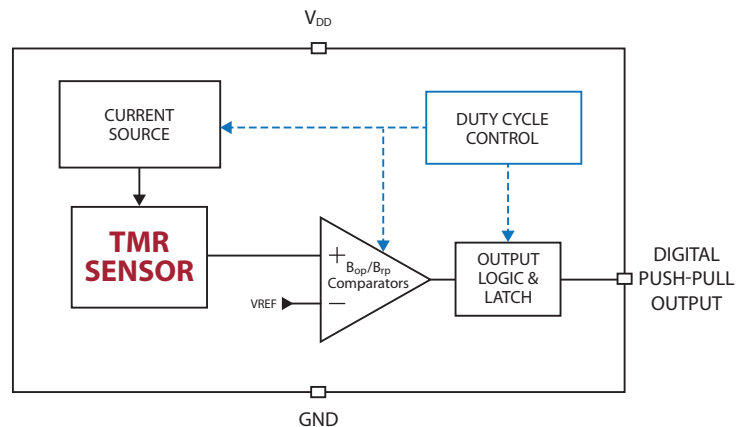

4 Specifications

4.1 Absolute Environmental Ratings^{1,2}

Parameters	Units	Min	Typ	Max
Operating Temperature (T_{OP})	°C	-40		+85
Storage Temperature (T_{STG})	°C	-65		+150
Junction Temperature (T_J)	°C			+150
Soldering Temperature (3 cycles, 1 min.) (T_{SOL})	°C			+260
ESD Level Human Body Model per JESD22-A114	V	±4000		
Magnetic Field Exposure	G			500

4.2 Absolute Electrical Ratings^{1,2}

Parameters	Units	Min	Typ	Max
Supply Voltage (V_{DD})	V	-0.3		+5.5
Push-pull Output (Active Low)(V_{OUT_PP})	V	-0.3		V_{DD}
Input and Output Current (I_{IN}/I_{OUT})	mA	-10		+10

4.3 Operating Electrical Characteristics for RR122-1A22-511 / 512³

Parameters	Units	Min	Typ	Max
Supply Voltage (V_{DD})	V	1.7		5.5
Power-On Time (t_{ON})($V_{DD} > 90\%$)	μs		50	75
Peak Power-On Current	mA			1.4
Active Mode Time (t_{ACT})	μs		1.4	
Output Voltage (High) (V_{OUTH})	V	90% V_{DD}		
Output Voltage (Low) (V_{OUTL})	V			10% V_{DD}
Under Voltage Lockout Threshold Rising V_{DD} ($V_{UVLO-RISE}$)	V		1.6	1.65
Under Voltage Lockout Threshold Falling V_{DD} ($V_{UVLO-FALL}$)	V	1.40	1.55	
Under Voltage Lockout Hysteresis ($V_{UV-HYST}$)	mV		50	
Average Supply Current @ $V_{DD} = 1.8$ V, $f_s = 10$ Hz	nA		100	
Average Supply Current @ $V_{DD} = 3.0$ V, $f_s = 10$ Hz	nA		140	

Notes:

- Exceeding Absolute Ratings may cause permanent damage to the device.
- Unless otherwise specified, all characteristics are measured at 25°C.
- Unless otherwise specified, $V_{DD} = 1.7$ V to 5.5 V, $T_A = -40$ °C to +85°C. Typical values are $V_{DD} = 3.0$ V and $T_A = +25$ °C.



ESD Note: This product uses semiconductors that can be damaged by electrostatic discharge (ESD). When handling, proper ESD precautions should be taken to avoid performance degradation or loss of functionality. Damage due to inappropriate handling is not covered under warranty.

4 Specifications (cont.)

4.4 Operating Characteristics for RR122-1A22-511 / 512^{1,2}

Parameters	Units	Min	Typ	Max
Switching Frequency (f_{SW})	Hz	7	10	13
Active Mode Time (t_{ACT})	μs		1.4	
Idle Mode Time (t_{IDLE})	ms		100	
Operate Point (B_{OPN})	G	8	9	12
Operate Point (B_{OPS})	G	-12	-9	-8
Release Point (B_{RPN})	G	3	5	7
Release Point (B_{RPS})	G	-7	-5	-3
Hysteresis (B_{HYST}) ⁴	G	2	4	

Notes:

1. Unless otherwise specified, $V_{DD} = 1.7\text{ V to }5.5\text{ V}$, $T_A = -40^\circ\text{C to }+85^\circ\text{C}$. Typical values are $V_{DD} = 3.0\text{ V}$ and $T_A = +25^\circ\text{C}$.

2. Conditions: $B_{HYST} = |B_{OP} - B_{RP}|$



ESD Note: This product uses semiconductors that can be damaged by electrostatic discharge (ESD). When handling, proper ESD precautions should be taken to avoid performance degradation or loss of functionality. Damage due to inappropriate handling is not covered under warranty.

5 Output Response vs. Magnetic Flux

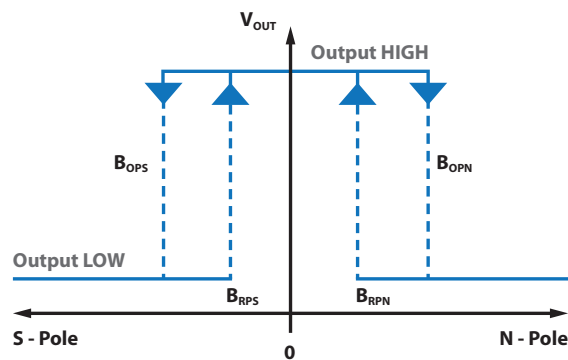

6 Application Information

RR122 Push-Pull Output Application Circuit

The output voltage on the RR122 is active low, meaning that while a sufficiently strong magnetic field is present, the output voltage is low. The output voltage can be connected to a digital I/O pin on a microcontroller. A decoupling capacitor between the supply voltage and ground is required with placement close to the magnetic sensor. A typical capacitor value of 1.0 μF will suffice.

6.1 Application Circuit (SOT-23-3)

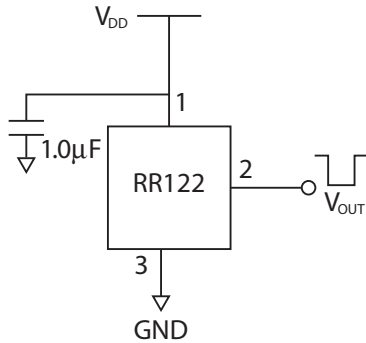

6.2 Application Circuit (LGA-4)

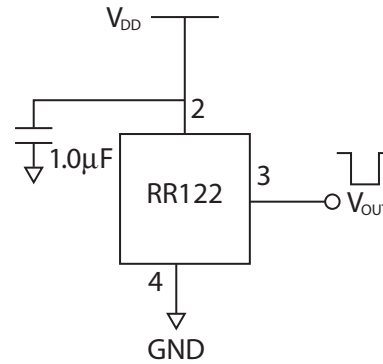

7 Axis of Sensitivity

7.1 SOT-23-3

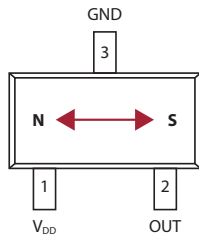

7.2 LGA-4

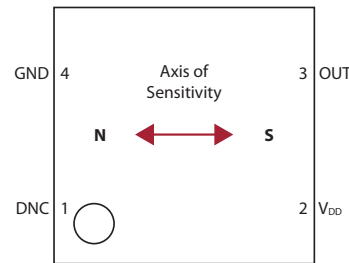

8 Dimensions *Millimeters (Inches)*

8.1 SOT-23-3 Package

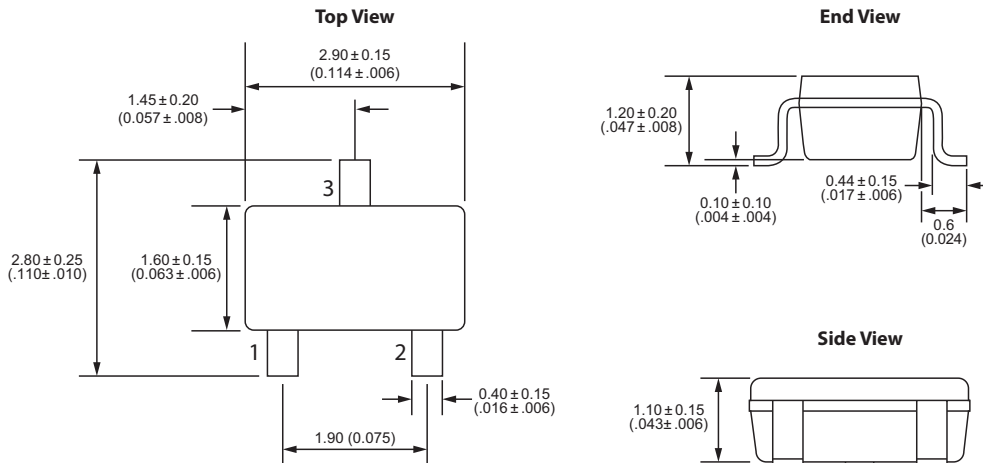

8 Dimensions Millimeters (Inches)

8.2 LGA-4 Package

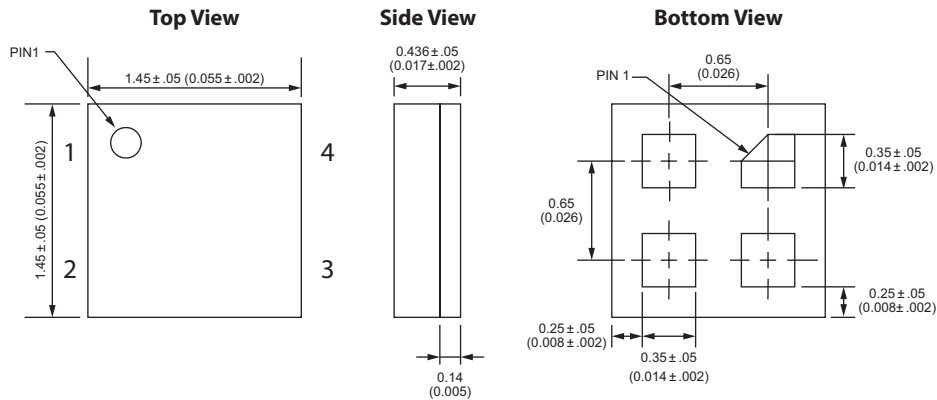

9 TMR Sensor Location

9.1 SOT-23-3 Package

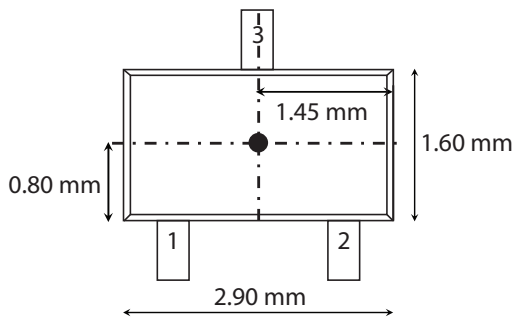

9.2 LGA-4 Package

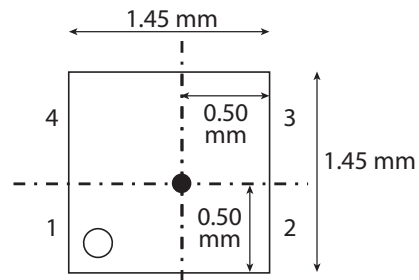

9.3 SOT Package - Side View

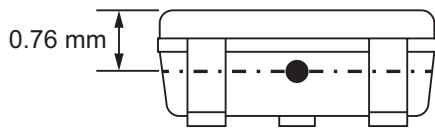

9.4 LGA Package - Side View



10 Output Behavior vs. Magnetic Field Diagrams

Output Behavior vs. Magnetic Field - Omnipolar

Characteristics	Conditions	Output
South Pole	$B < B_{OPS}$ $0 > B > B_{RPS}$	Low (ON) High (OFF)
North Pole	$B > B_{OPN}$ $0 < B < B_{RPN}$	Low (ON) High (OFF)

11 TMR Sensor & Switch Packaging

11.1 SOT-23-3 Tape & Reel Packaging

Standard packaging is Tape & Reel containing 3,000 pieces. MSL Rating is 1.

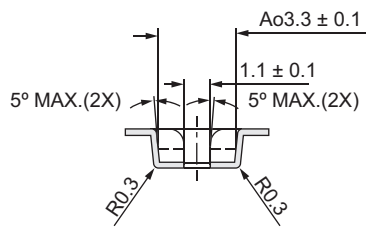
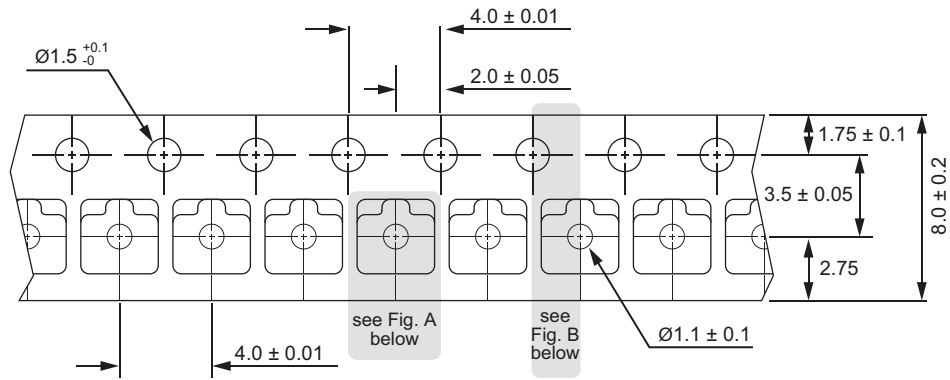

Fig. A

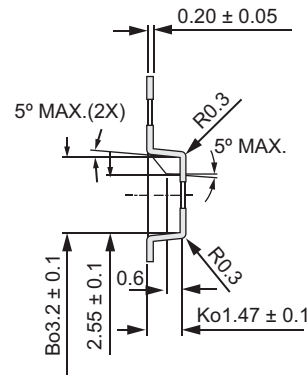
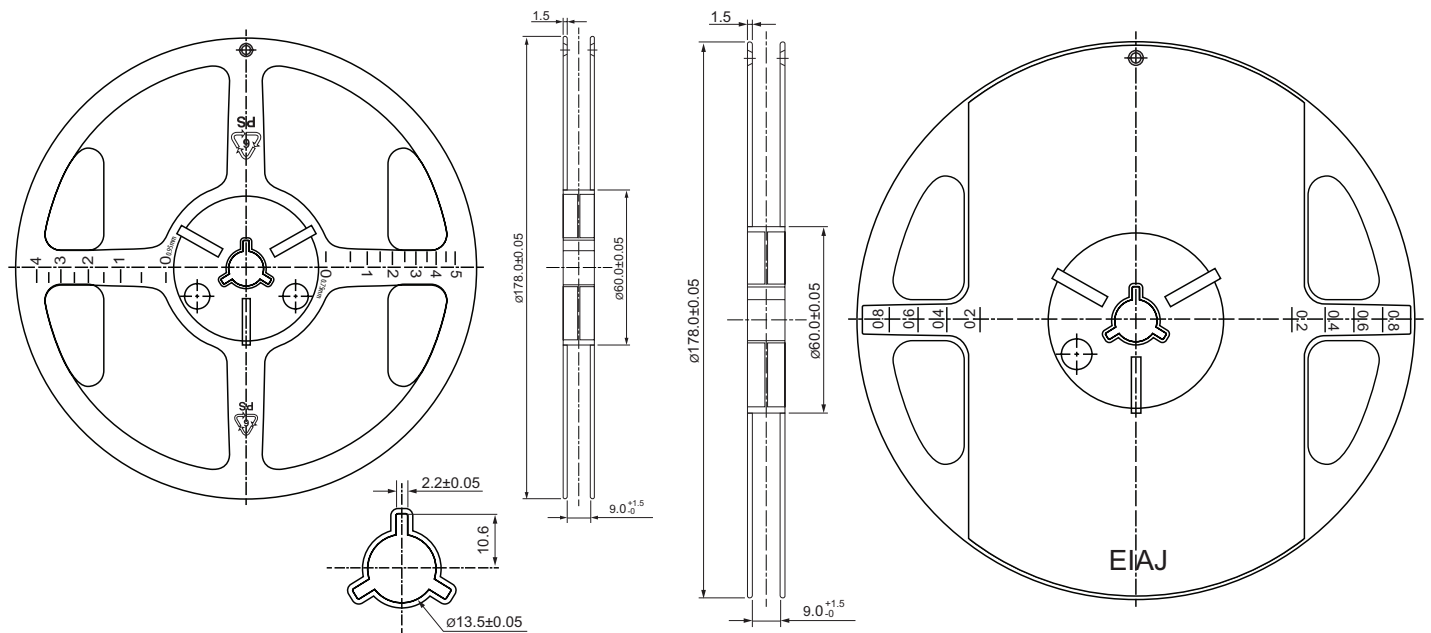

Fig. B



11 TMR Sensor & Switch Packaging

11.3 RedRock TMR Packaging

Box Dimensions – 14x10x6 inches

- Fits 1 to 3 reels = 3000 to 9000 pcs
- Weight for 3000 pcs = 0.90 kilos
- Weight for 9000 pcs = 1.00 kilos

Box Dimensions – 18x14x12 inches

- Fits 4 to 24 reels = 12000 to 72000 pcs
- Weight for 12000 pcs = 1.50 kilos
- Weight for 72000 pcs = 4.90 kilos

12 Suggested Pb-Free Reflow Profile

Notes:

1. Fully compatible with standard no-lead solder profile, 260°C for 30 seconds max (3 cycles max).
2. Profile shown as example. Users are advised to develop their own board-level profile.
3. Suggested Pb-free reflow profile derived from IPC/JEDEC J-STD-020E.
4. Temperature tolerance: +0°C, as measured at any point on the package or leads
5. MSL rating of 1 (SOT-23-3 only) compatible with J-STD-020 or equivalent.
6. MSL rating of 3 (LGA-4 and Leaded LGA-4) compatible with J-STD-020 or equivalent.
7. All temperatures refer to the center of the package, measured on the package body surface that is facing up during assembly reflow (e.g., live-bug). If parts are reflowed in other than the normal live bug assembly reflow orientation (i.e., dead-bug), T_p shall be within $\pm 2^\circ\text{C}$ of the live bug T_p and still meet the T_c requirements, otherwise, the profile shall be adjusted to achieve the latter. To accurately measure actual peak package body temperatures, refer to JEP140 for recommended thermocouple use.
8. Reflow profiles in this document are for classification/preconditioning and are not meant to specify board assembly profiles. Actual board assembly profiles should be developed based on specific process needs and board designs and should not exceed the parameters in this table.

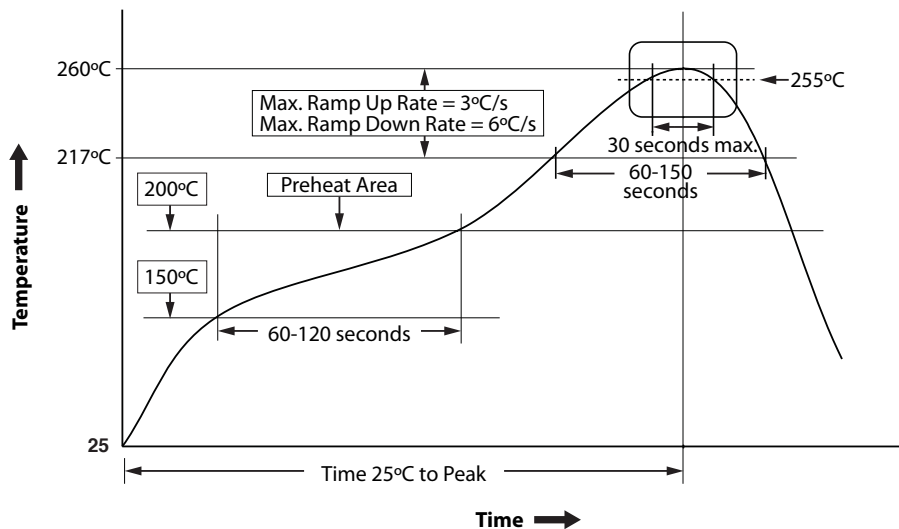

13 Suggested Solder Pad Layout

Dimensions in mm (inches)

13.1 SOT-23-3 Solder Pad Layout

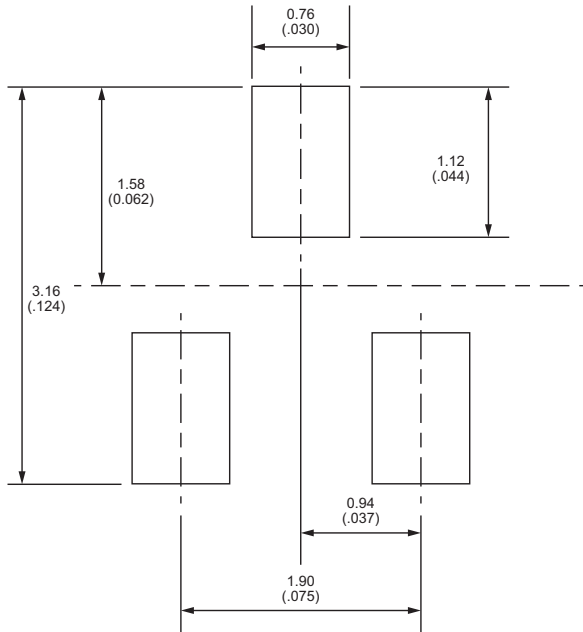

13.2 LGA-4 Solder Pad Layout

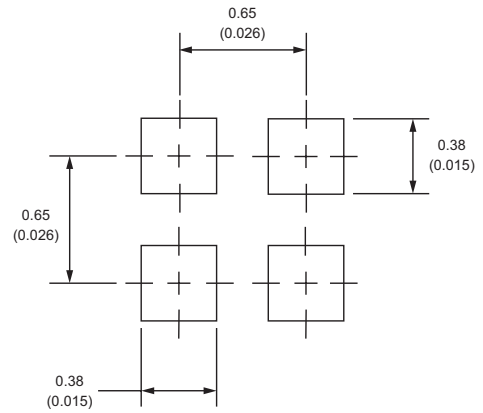

14 Graphs - Typical Electrical Characteristics

$C_{DD} = 1.0 \mu\text{F}$ (unless otherwise specified)

**14.1 RR122-1A22-511 / 512
Average Supply Current vs.
Supply Voltage vs. Temperature**

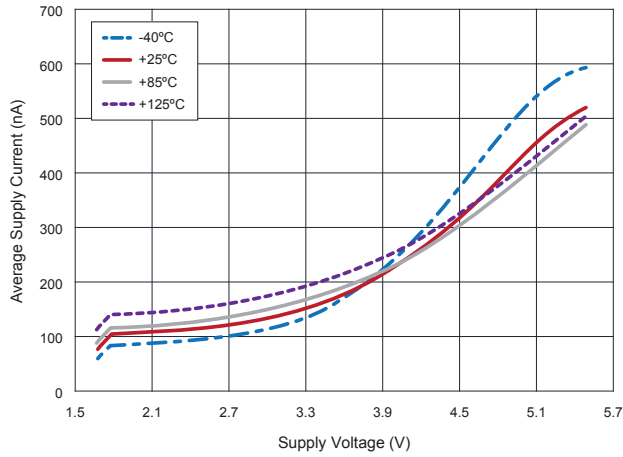

**14.2 RR122-1A22-511 / 512
Average Supply Current vs.
Temperature vs. Supply Voltage**

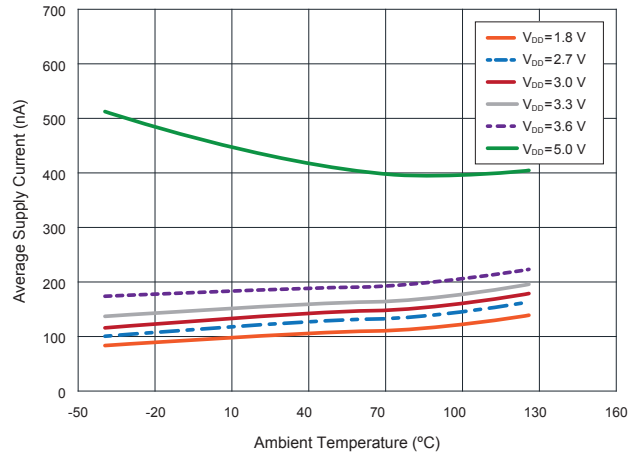

**14.3 RR122-1A22-511 / 512
Sampling Frequency vs.
Supply Voltage vs. Temperature**

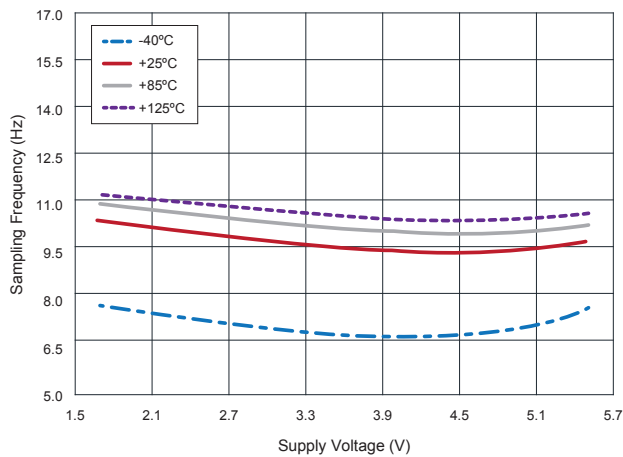

14 Graphs - Typical Magnetic Characteristics

$C_{DD} = 1.0 \mu\text{F}$ (unless otherwise specified)

14.4 RR122-1A22-511 / 512
 B_{OPN} (Blue) and B_{OPS} (Red) vs.
Supply Voltage at +25°C

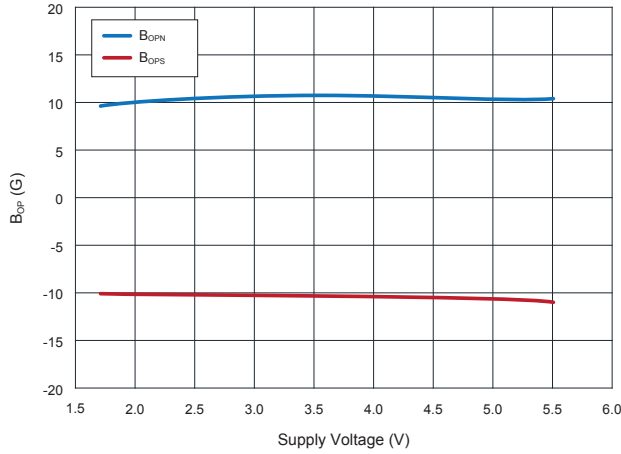

14.5 RR122-1A22-511 / 512
 B_{RPN} (Blue) and B_{RPS} (Red) vs.
Supply Voltage at +25°C

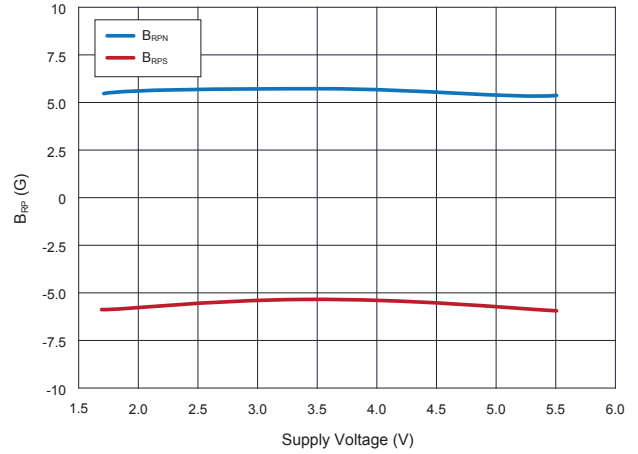

14.6 RR122-1A22-511 / 512
 B_{OPN} (Blue) and B_{OPS} (Red) vs.
Operating Temperature at $V_{DD}=3.0\text{ V}$

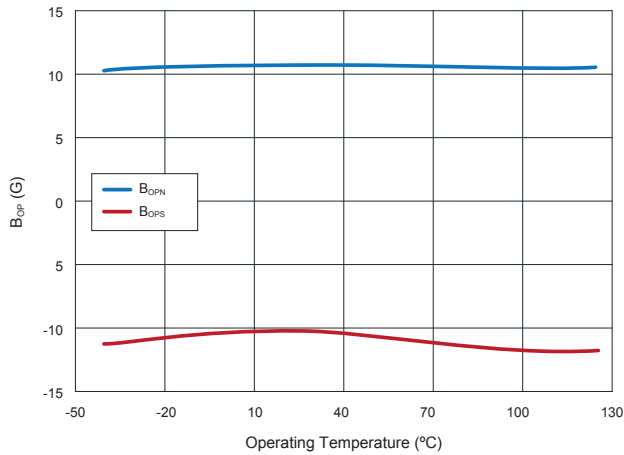

14.7 RR122-1A22-511 / 512
 B_{RPN} (Blue) and B_{RPS} (Red) vs.
Operating Temperature at $V_{DD}=3.0\text{ V}$

