

RH Series — General Purpose Midget Relays

Key features of the RH series include:

- Compact midget size saves space
- High switching capacity (10A)
- Choice of blade or PCB style terminals
- Relay options include indicator light, check button, and top mounting bracket
- DIN rail, surface, panel, and PCB type sockets available for a wide range of mounting applications

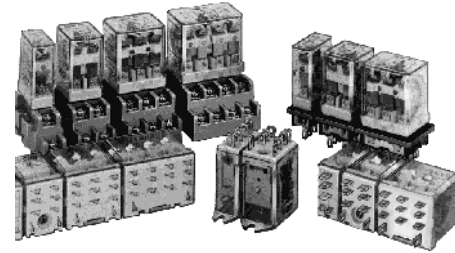

UL Recognized
Files No. RH1 = E66043
RH2 = E66043
RH3 = E66043
RH4 = E55996



CSA Certified
File No. LR35144



File No. B020813332452



E

Relays

Specifications

Contact Material	Silver cadmium oxide
Contact Resistance	50mΩ maximum (initial value)
Minimum Applicable Load	24V DC/30mA, 5V DC/100mA (reference value)
Operating Time	SPDT (RH1), DPDT (RH2): 20ms maximum 3PDT (RH3), 4PDT (RH4): 25ms maximum
Release Time	SPDT (RH1), DPDT (RH2): 20ms maximum 3PDT (RH3), 4PDT (RH4): 25ms maximum
Maximum Continuous Applied Voltage (AC/DC) at 20°C	110% of the rated voltage
Minimum Operating Voltage (AC/DC) at 20°C	80% of the rated voltage
Drop-Out Voltage (AC)	30% or more of the rated voltage
Drop-Out Voltage (DC)	10% or more of the rated voltage
Power Consumption	SPDT (RH1): DC: 0.8W AC: 1.1VA (50Hz), 1VA (60Hz) DPDT (RH2): DC: 0.9W AC: 1.4VA (50Hz), 1.2VA (60Hz) 3PDT (RH3): DC: 1.5W AC: 2VA (50Hz), 1.7VA (60Hz) 4PDT (RH4): DC: 1.5W AC: 2.5VA (50Hz), 2VA (60Hz)
Insulation Resistance	100MΩ min (measured with a 500V DC megger)
Dielectric Strength	SPDT (RH1) Between live and dead parts: 2,000V AC, 1 minute; Between contact circuit and operating coil: 2,000V AC, 1 minute; Between contacts of the same pole: 1,000V AC, 1 minute DPDT (RH2), 3PDT (RH3), 4PDT (RH4) Between live and dead parts: 2,000V AC, 1 minute; Between contact circuit and operating coil: 2,000V AC, 1 minute; Between contact circuits: 2,000V AC, 1 minute; Between contacts of the same pole: 1,000V AC, 1 minute
Frequency Response	1,800 operations/hour
Temperature Rise	Coil: 85°C maximum Contact: 65°C maximum
Vibration Resistance	0 to 6G (55Hz maximum)
Shock Resistance	SPDT/DPDT: 200N (approximately 20G) 3PDT/4PDT: 100N (approximately 10G)
Life Expectancy	Electrical: over 500,000 operations at 120V AC, 10A; (over 200,000 operations at 120V AC, 10A for SPDT [RH1], 3PDT [RH3], 4PDT [RH4]) Mechanical: 50,000,000 operations
Operating Temperature	-30 to +70°C
Weight	SPDT: 24g, DPDT: 37g (approximately) 3PDT: 50g, 4PDT: 74g (approximately)

Ordering Information

Order standard voltages for fastest delivery. Allow extra delivery time for non-standard voltages.

Basic Part No.

RH2B-U

Coil Voltage:

AC110-120V

Part Numbers

Part Numbers: RH Series with Options

Termination	Contact Configuration	Basic Part No.	Indicator Light	Check Button	Indicator Light and Check Button	Top Bracket
B (blade)	SPDT	RH1B-U	RH1B-UL	RH1B-UC	RH1B-ULC	RH1B-UT
	DPDT	RH2B-U	RH2B-UL	RH2B-UC	RH2B-ULC	RH2B-UT
	3PDT	RH3B-U	RH3B-UL	RH3B-UC	RH3B-ULC	RH3B-UT
	4PDT	RH4B-U	RH4B-UL	RH4B-UC	RH4B-ULC	RH4B-UT
V2 (PCB 0.078" [2mm] wide)	SPDT	RH1V2-U	RH1V2-UL	RH1V2-UC	RH1V2-ULC	—
	DPDT	RH2V2-U	RH2V2-UL	RH2V2-UC	RH2V2-ULC	—
	3PDT	RH3V2-U	RH3V2-UL	RH3V2-UC	RH3V2-ULC	—
	4PDT	RH4V2-U	RH4V2-UL	RH4V2-UC	RH4V2-ULC	—

Ratings

Coil Ratings

Rated Voltage	Rated Current ±15% at 20°C								Coil Resistance ±15% at 20°C				
	60Hz				50Hz				SPDT	DPDT	3PDT	4PDT	
	SPDT	DPDT	3PDT	4PDT	SPDT	DPDT	3PDT	4PDT					
AC	6V	150mA	200mA	280mA	330mA	170mA	238mA	330mA	387mA	18.8Ω	9.4Ω	6.0Ω	5.4Ω
	12V	75mA	100mA	140mA	165mA	86mA	118mA	165mA	196mA	76.8Ω	39.3Ω	25.3Ω	21.2Ω
	24V	37mA	50mA	70mA	83mA	42mA	59.7mA	81mA	98mA	300Ω	153Ω	103Ω	84.5Ω
	120V*	7.5mA	11mA	14.2mA	16.5mA	8.6mA	12.9mA	16.4mA	19.5mA	7,680Ω	4,170Ω	2770Ω	2220Ω
	240V†	3.2mA	5.5mA	7.1mA	8.3mA	3.7mA	6.5mA	8.2mA	9.8mA	3,1200Ω	15,210Ω	12,100Ω	9120Ω
DC		SPDT	DPDT	3PDT	4PDT	SPDT	DPDT	3PDT	4PDT	SPDT	DPDT	3PDT	4PDT
	6V	128mA	150mA	240mA	250mA	47Ω	40Ω	25Ω	24Ω				
	12V	64mA	75mA	120mA	125mA	188Ω	160Ω	100Ω	96Ω				
	24V	32mA	36.9mA	60mA	62mA	750Ω	650Ω	400Ω	388Ω				
	48V	18mA	18.5mA	30mA	31mA	2,660Ω	2,600Ω	1,600Ω	1550Ω				
110V‡	8mA	9.1mA	12.8mA	15mA	13,800Ω	12,100Ω	8,600Ω	7,340Ω					



* For RH2 relays = 110/120V AC.
 † For RH2 relays = 220/240V AC.
 ‡ For RH2 relays = 100/110V DC.

Rated Voltage	Coil Inrush				Coil Inductance								
					Energizing				De-Energizing				
	SPDT	DPDT	3PDT	4PDT	SPDT	DPDT	3PDT	4PDT	SPDT	DPDT	3PDT	4PDT	
AC	6V	250mA	340mA	520mA	620mA	0.09H	0.08H	0.05H	0.05H	0.06H	0.04H	0.03H	0.02H
	12V	120mA	170mA	260mA	310mA	0.037H	0.30H	0.22H	0.18H	0.22H	0.16H	0.12H	0.10H
	24V	56mA	85mA	130mA	165mA	1.5H	1.2H	0.9H	0.73H	0.9H	0.63H	0.5H	0.36H
	120V*	12mA	16mA	26mA	33mA	37H	33H	21H	18H	22H	15H	12H	9H
	240V†	7mA	8mA	12mA	16mA	130H	130H	84H	73H	77H	62H	47H	36H
DC		SPDT	DPDT	3PDT	4PDT	SPDT	DPDT	3PDT	4PDT	SPDT	DPDT	3PDT	4PDT
	6V												
	12V												
	24V	N/A	N/A	N/A	N/A	N/A	N/A	N/A	N/A	N/A	N/A	N/A	N/A
	48V												
110V													



* For RH2 relays = 110/120V AC.
 † For RH2 relays = 220/240V AC.

E

Relays

Ratings con't

Contact Ratings

# of Poles	Max Contact Power		General Ratings		
	Resistive	Inductive	Voltage	Resistive	Inductive*
RH1	AC1540VA DC300W	AC990VA DC210W	AC110	10A	7A
			AC220	7A	4.5A
			DC30	10A	7A
RH2 RH3 RH4	AC1650VA DC300W	AC1100VA DC225W	AC110	10A	7.5A
			AC220	7.5A	5A
			DC30	10A	7.5A



* $\cos\phi = 0.3$
L/R - 7ms

CSA Ratings

Voltage	Resistive				General Use				HP Rating
	RH1	RH2	RH3	RH4	RH1	RH2	RH3	RH4	RH1, 2, 3
AC240V	10A	10A	—	7.5A	7A	7A	7A	5A	1/3HP
AC120V	10A	10A	10A	10A	7.5A	7.5A	—	7.5A	1/6HP
DC30V	10A	10A	10A	10A	7A	7.5A	—	—	—

UL Ratings

Voltage	Resistive			General Use			Horse Power Rating	
	RH1, RH2	RH3	RH4	RH1, RH2	RH3	RH4	RH1, RH2 RH3	
AC240V	10A	7.5A	7.5A	7A	6.5A	5A	1/3HP	
AC120V	10A	10A	10A	7A	7.5A	7.5A	1/6HP	
DC30V	10A	10A	—	7A	—	—	—	—
DC28V	10A	10A	10A	7A	—	—	—	—

TÜV Ratings

Voltage	RH1	RH2	RH3	RH4
AC240V	10A	10A	7.5A	7.5A
DC30V	10A	10A	10A	10A

Relays

Applicable Sockets

Part Numbers: Sockets

Relay	Standard DIN Rail Mount	Finger-Safe DIN Rail Mount	Surface Mount	Panel Mount	PCB Mount
RH1B	SH1B-05	SH1B-05C	—	SH1B-51	SH1B-62
RH2B	SH2B-05	SH2B-05C	SH2B-02	SH2B-51	SH2B-62
RH3B	SH3B-05	SH3B-05C	—	SH3B-51	SH3B-62
RH4B	SH4B-05	SH4B-05C	—	SH4B-51	SH4B-62

Spring & Clips (optional)	
Part Number	Use With
SY2S-02F1 ^③ SFA-101 ^① SFA-202 ^②	SH1B-05, 05C
SY4S-51F1 ^③ SFA-301 ^① SFA-302 ^②	SH1B-51, 62
SY4S-02F1 ^③ SFA-101 ^① SFA-202 ^②	SH2B-05, 05C
SY4S-51F1 ^③ SFA-301 ^① SFA-302 ^②	SH2B-51, 62
SH3B-05F1 ^③ SFA-101 ^① , -202 ^②	SH3B-05, 05C
SY4S-51F1 ^③ SFA-301 ^① SFA-302 ^②	SH3B-51, 62
SH4B-02F1 ^③ SFA-101 ^① , -202 ^②	SH4B-05, 05C
SY4S-51F1 ^③ SFA-301 ^① SFA-302 ^②	SH4B-51, 62



See Section F for details on sockets. All DIN rail mount sockets shown above can be mounted using DIN rail BNDN1000.



- ① Top latch
- ② Side latch
- ③ Pullover spring

Internal Circuits

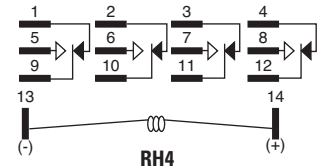
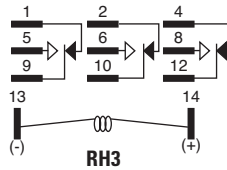
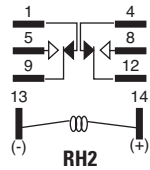
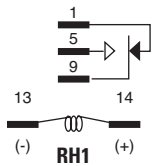
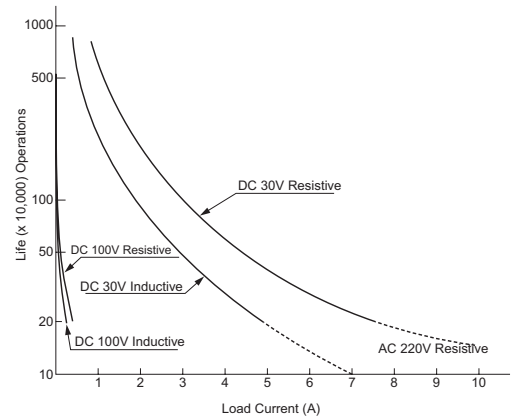
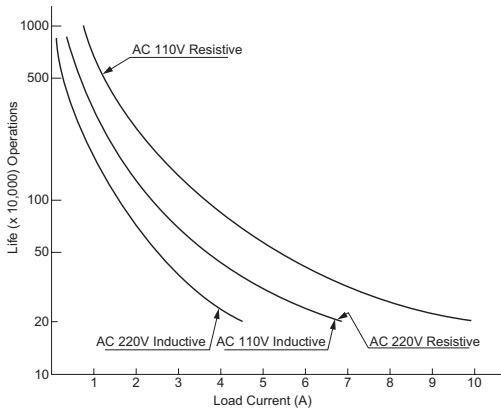

Image as viewed from bottom of relay. Refer to socket for exact wiring layout (Section F).

Electrical Life Curves

RH1



RH2

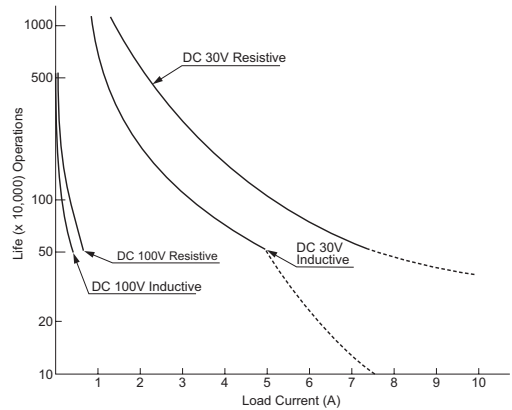
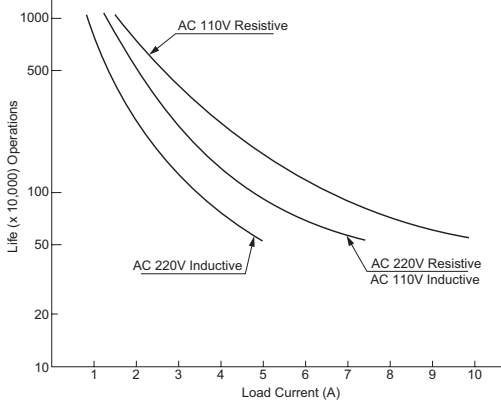

RH3

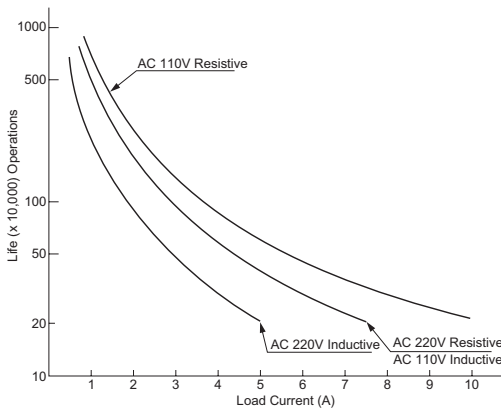

RH4

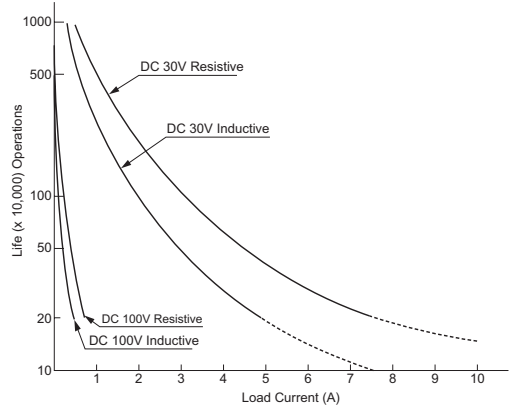

Maximum Switching Capacity

RH1

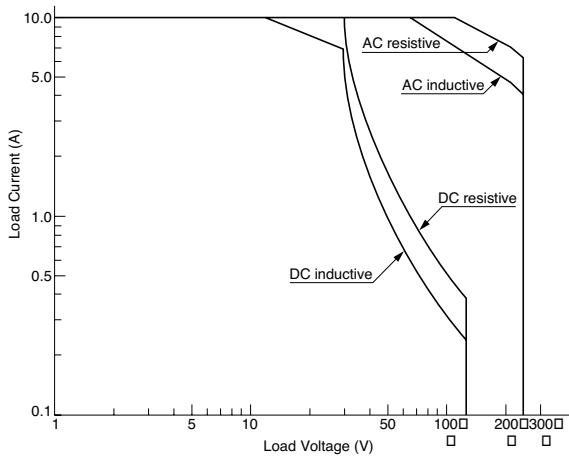

RH2/RH3/RH4

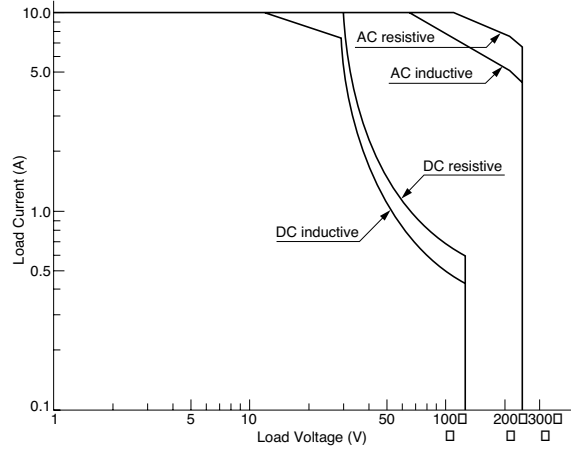

Relays

Dimensions

**Top Bracket Mounting
Blade Terminal
RH1B-UT**

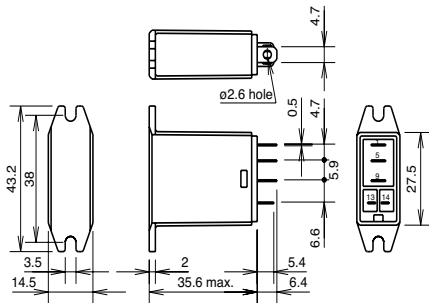

RH2B-UT

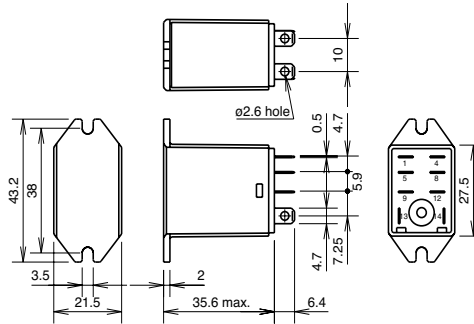

**Plug-in Blade Terminal
RH1B**

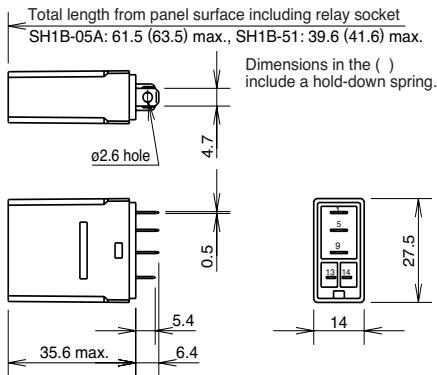

RH2B

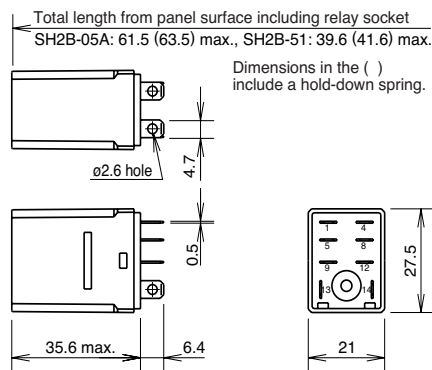

All dimensions in mm.

Dimensions con't

Plug-in Blade Terminal RH3B

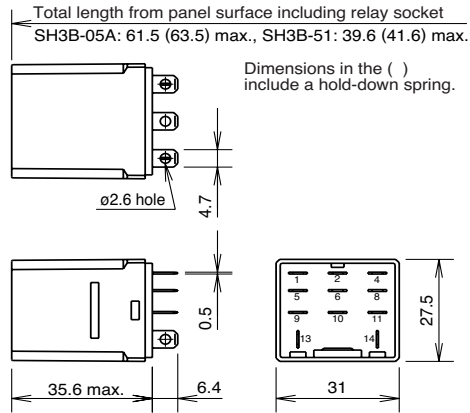

RH4B

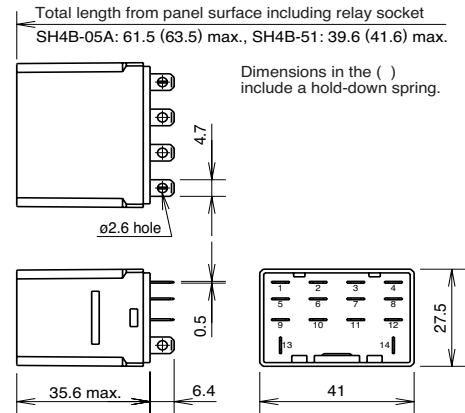

PCB Terminal RH1V2

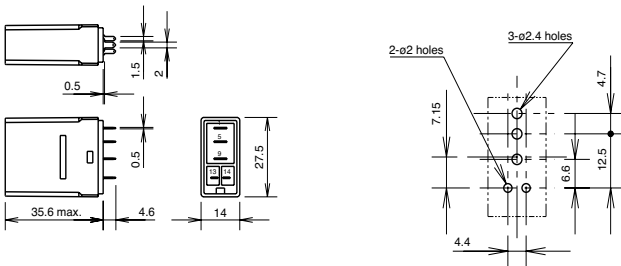

RH2V2

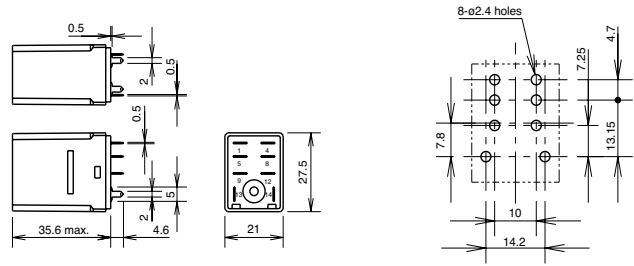

RH3V2

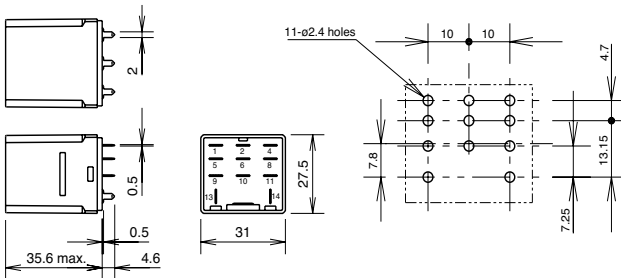

RH4V2

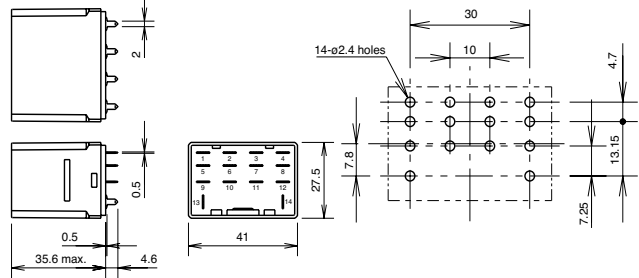

RH3B-UT

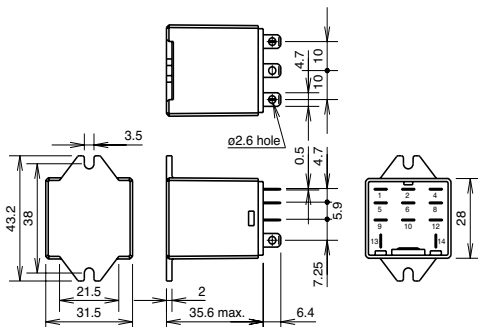

RH4B-UT

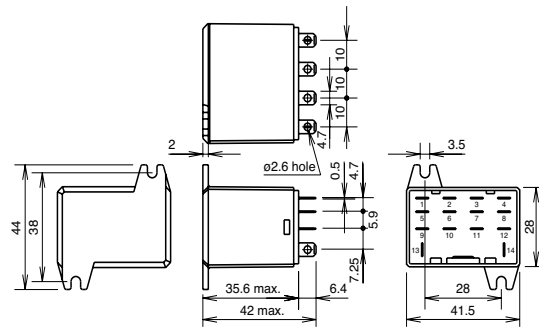

All dimensions in mm.

