

**RIGHT ANGLE JACK RECEPTACLE
FOR PCB SOLDER LEGS**

R141.665.200

Series : **BNC 50**

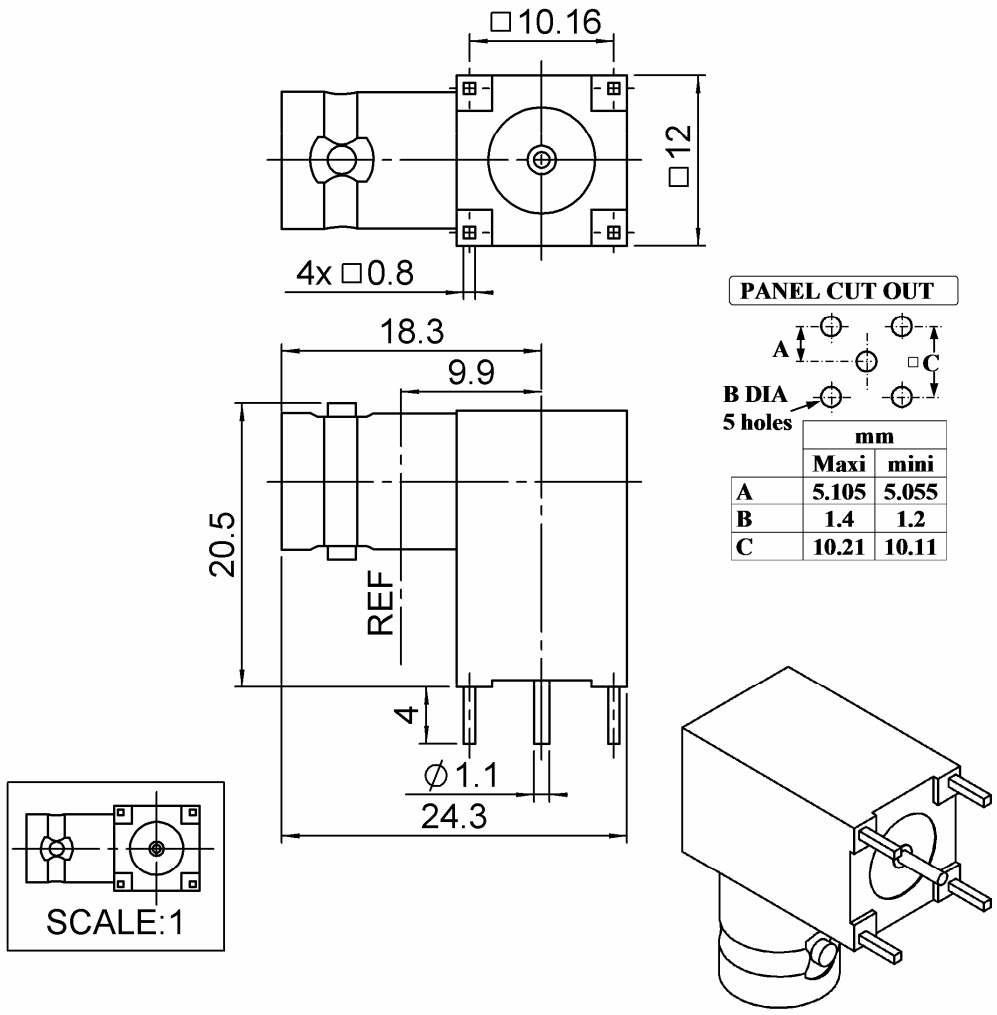

All dimensions are in mm.

COMPONENTS	MATERIALS	PLATING (µm)
BODY	BRASS	NICKEL
CENTER CONTACT	BRONZE	GOLD
OUTER CONTACT		
INSULATOR	PTFE	
GASKET		
OTHERS PARTS		
-	-	-
-	-	-

Issue : 0910 A

In the effort to improve our products, we reserve the right to make changes judged to be necessary.



**RIGHT ANGLE JACK RECEPTACLE
FOR PCB SOLDER LEGS**

R141.665.200

Series : **BNC 50**

PACKAGING

Standard	Unit	Other
100	'W' option	Contact us

SPECIFICATION

ELECTRICAL CHARACTERISTICS

Impedance		50 Ω
Frequency		0-1.5 GHz
VSWR	10.8 +	0.006 x F(GHz) Maxi
Insertion loss		.035* √F(GHz) dB Maxi
RF leakage	- (57 - F(GHz)) dB Maxi
Voltage rating		500 Veff Maxi
Dielectric withstanding voltage		1500 Veff mini
Insulation resistance		5000 MΩ mini

ENVIRONMENTAL

Operating temperature	-35/+70 ° C
Hermetic seal	NA Atm.cm3/s
Panel leakage	NA

OTHER CHARACTERISTICS

Assembly instruction **NA**

Others :

*Coaxial Transmission Line Only

MECHANICAL CHARACTERISTICS

Center contact retention		
Axial force – Mating end		15 N mini
Axial force – Opposite end		15 N mini
Torque		NA N.cm mini
Recommended torque		
Mating		NA N.cm
Panel nut		NA N.cm
Mating life		100 Cycles mini
Weight		22.100 g

Issue : 0910 A

In the effort to improve our products, we reserve the right to make changes judged to be necessary.

