

veam

FRCIRM12  
Data Transmission  
Connectors  
Catalog



**ITT**

ENGINEERED FOR LIFE

# We Connect

When it matters most

ITT's Veam brand is a leading global manufacturer of connector products serving international customers in multiple end markets.

In an increasingly global economy, getting from Point A to Point B on time and on budget is more important than ever. VEAM connectors protect the world's products and people in transit so they can get to where they're going with maximum efficiency.

## Proven quality, reliability and expertise

### **The ITT Cannon difference**

- Global capabilities & local support
- Proven application expertise
- A century of interconnect leadership
- A committed innovator & business partner

### **About ITT**

ITT is a diversified leading manufacturer of highly engineered critical components and customized technology solutions for the energy, transportation and industrial markets.

Building on its heritage of innovation, ITT partners with its customers to deliver enduring solutions to the key industries that underpin our modern way of life. Founded in 1920, ITT is headquartered in White Plains, N.Y., with employees in more than 35 countries and sales in a total of approximately 125 countries. For more information, visit [www.itt.com](http://www.itt.com).



# Veam FRCIR-M12 Series Connectors



### THE CHALLENGE

As railway technology and safety standard advance, so must the electronics supporting applications like engine diagnostics, brake controls, environmental conditioning, passenger display systems, networking and lighting control. This coupled with the increasing demand for data grouping and through-put is why ITT Veam was approached with this challenge.

The customer requested an interconnect solutions to establish reliable connection between coaches. In particular, these solution for data transmission must bundled multiple Ethernet, Video, WTB, MVB and signal lines in general into a singular connector while meeting all required regulations.

### THE SOLUTION

Listening to our customer requests, ITT Veam met the challenge by developing the FRCIR-M12 Series. This series is a combination of M12 contacts mounted into FRCIR connector series hardware. With this pioneering design, four conductor wires and the associated braid from shielded cables are integrated into the M12 contact. A special plastic insert groups multiple M12 contacts and their cables into a singular connector. With this solution, the customer may now transfer local data from Ethernet, MVB, WTB, Video lines and signal in general, according to VG95234, within the same connector.

### The Veam Difference:

- Smaller footprint by combining multiple lines in the same connector
- Suitable for harsh environment
- Available with up to 500h salt spray resistant RoHS conductive plating and considering non conductive plating up to 1000h
- Superior shielding performance

- Seven Connector Configurations
  - › 1 way based on size 18 shell
  - › 2-3 and 4 way based on size 32 shell
  - › 7 way based on size 290 shell
  - › 7 way plus 6 size 12 contacts based on size 290 shell
- Customized Contact Configurations
  - › 1-Pole repairable (CXI-series)
  - › 2-Poles crimp and repairable (TX-series)
  - › 4-Poles crimp and repairable (QX-series)
  - › 8-Poles repairable (EXI-series)



1- INTER-VEHICLES

2- CONVERTERS / INVERTERS

3- ELECTRIC COUPLERS

4- DATA COMMUNICATION

## FRCIRM12 PRODUCT INTRODUCTION



- The FRCIRM12 connector series is based on VG95234 specification.
- FRCIRM12 connectors are available in 7 size arrangements based on the following shell size 18, 32 and 290.
- The contact system enables easy insertion and removal. The inserts are composed of halogen free hard plastic material that results in a very low fire hazard.
- Stainless steel bayonet pins riding along the three Bayonet ramps (machined into the receptacle shell) achieve the connector coupling. Coupling integrity is guaranteed by:
  - Three stainless steel pins at the critical wear points of the receptacle shell bayonet ramps
  - An audible click when fully mated
  - Alignment of three yellow colored dots when fully mated
- The stainless steel pins installed on the critical wear points of the ramps, the dynamic coupling gasket at the base of the plugshell, the flat and the wave washer between the coupling nut and the plugshell, are the key features that allow to prevent the unmating of the connection in case of vibration and guarantees the high reliability of the bayonet mating system.
- IP67 environmental sealing of mated connectors is achieved by compression of coupling gasket; at the rear side is achieved by using the grommet with an appropriate accessory.
- Each layout allowed to use different contacts type following data transmission request giving customer unique layout with multiple choice.
- The innovative contact technology enable data signals to be interconnected in one operation up to 7 lines.

# TABLE OF CONTENTS

---

Technical information	9	Connectors type (32PM12- - -)	27
Components description	10	Connectors type (290PM12- - -)	35
Order code	11	Accessories	37
Inserts arrangements	14	Application notes	40
Contacts scenario	18	General info	42
Connectors type (18PM12- - -)	25		

---



## Additional Information on Ethernet and Cabling Standards

Ethernet based technologies are defined by IEEE 802.1 and 802.3 standard families. In particular, the IEEE 802.3 group specifies the performance and versions for wired networks. There are no specific cabling standards for railcars, so industry players mainly refer to ISO/IEC11801 – information technology – generic cabling for customer premises specifications for transmission.

ISO/IEC 11801 specifies general-purpose telecommunication cabling systems (structured cabling) that are suitable for a wide range of applications, such as analog and ISDN telephony, various data communication standards, control systems, factory automation, etc. The standard covers both balanced copper cabling and optical fiber cabling.

This standard specifies generic installation and design topologies that are characterized by a “category” or “class” of transmission performance. It defines several link/channel classes and cabling categories of twisted-pair copper interconnects, which differ in the maximum frequency for which a certain channel performance is required:

- Class A: link/channel up to 100 kHz using Category 1 cable/connectors
- Class B: link/channel up to 1 MHz using Category 2 cable/connectors
- Class C: link/channel up to 16 MHz using Category 3 cable/connectors
- Class D: link/channel up to 100 MHz using Category 5e cable/connectors
- Class E: link/channel up to 250 MHz using Category 6 cable/connectors
- Class EA: link/channel up to 500 MHz using Category 6A cable/connectors
- Class F: link/channel up to 600 MHz using Category 7 cable/connectors
- Class FA: link/channel up to 1000 MHz using Category 7A cable/connectors

ISO/IEC 11801-Annex E, Acronyms for balanced cables, provides a system to specify the exact construction for both unshielded and shielded balanced twisted-pair cables. It uses three letters - U for unshielded, S for braided shielding, and F for foil shielding - to form a two-part abbreviation in the form of xx/xTP, where the first part specifies the type of overall cable shielding, and the second part specifies shielding for individual cable elements.

Common cable types include U/UTP (unshielded cable); U/FTP (individual pair shielding without the overall screen); F/UTP, S/UTP, or SF/UTP (overall screen without individual shielding); and F/FTP, S/FTP, or SF/FTP (overall screen with individual foil shielding).

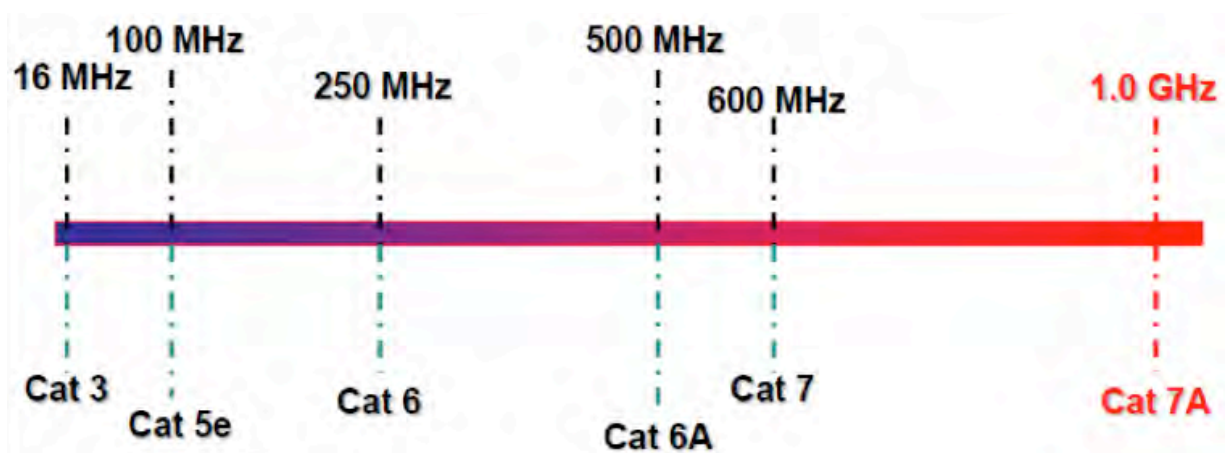

## ETHERNET STRUCTURED CABLING STANDARDS AND CORRESPONDING FREQUENCY RANGES

ISO/IEC 11801 also defines several classes of optical fiber interconnect:

OM1: Multimode fiber type 62.5  $\mu\text{m}$  core; minimum modal bandwidth of 200 MHz·km at 850 nm

- OM2: Multimode fiber type 50  $\mu\text{m}$  core; minimum modal bandwidth of 500 MHz·km at 850 nm
- OM3: Multimode fiber type 50  $\mu\text{m}$  core; minimum modal bandwidth of 2000 MHz·km at 850 nm
- OM4: Multimode fiber type 50  $\mu\text{m}$  core; minimum modal bandwidth of 4700 MHz·km at 850 nm
- OS1: Single-mode fiber type 1 db/km attenuation
- OS2: Single-mode fiber type 0.4 db/km attenuation

The cabling standards are subsequently referenced in applications standards, such as IEEE for Ethernet, as a minimum level of performance necessary to ensure application operation.

Table 1 below explains the correspondence between Ethernet applications and twisted-pair wiring systems.

Class	Ethernet applications	Maximum application data rate	Number of pairs needed	Maximum Bandwidth	Cable construction	Maximum Channel Length
C	10 Base-T	10 Mbps	2	16 MHz	Unshielded or Shielded	100 m
D	10 Base-T 100 Base-TX 1000 Base-T	10 Mbps 100 Mbps 1 Gbps	2 2 4	100 MHz	Unshielded or Shielded	100 m
E	10 Base-T 100 Base-TX 1000 Base-T	10 Mbps 100 Mbps 1 Gbps	2 2 4	250 MHz	Unshielded or Shielded	100 m
E <sub>A</sub>	10 Base-T 100 Base-TX 1000 Base-T 10 GBase-T	10 Mbps 100 Mbps 1 Gbps 10 Gbps	2 2 4 4	500 MHz	Unshielded or Shielded	100 m
F	10 Base-T 100 Base-TX 1000 Base-T 10 GBase-T	10 Mbps 100 Mbps 1 Gbps 10 Gbps	2 2 4 4	600 MHz	Shielded Only	100 m
F <sub>A</sub>	10 Base-T 100 Base-TX 1000 Base-T 10 GBase-T	10 Mbps 100 Mbps 1 Gbps 10 Gbps	2 2 4 4	1000 MHz	Shielded Only	100 m

# FRCIRM12 TECHNICAL INFORMATION

## MATERIAL CONSTRUCTION

**Shells:** Aluminum alloy  
**Available Platings:** T240: Blue Zn/Ni - Conductive  
 T39: Black varnish - Non-conductive  
 T891: Black hard anodizing - Non-conductive

**Insulator:** Low fire hazard thermoplastic EN45545 (HL3) R22-23.  
**Grommet:** Low fire hazard silicone rubber EN45545 (HL3) R22-23  
**Contacts:** Copper alloy with gold plating  
 Zama alloy zink-nickel plating

## ENVIRONMENTAL PERFORMANCE

**Operating Temperature:** -40°C to +100°C  
**Corrosion Resistance:** T240: Blue Zn/Ni – 500 H Salt Spray - Conductive  
 T108: Zinc/Cobalt – 200 H salt Spray - Conductive  
 T39: Black varnish – 500 H Salt Spray - Non-conductive  
 T891: Black hard anodizing – 1000 H Salt Spray - Non-conductive

**Water Protection:** IP67 in mated condition when used with proper backshell and accessories  
**Fluid Resistance:** Gas, oil, mineral oil, acid bath per NF F 61-030  
**Fire and smoke:** Rated HL3 - R22/R23 acc. to EN 45545-2

## MECHANICAL PERFORMANCE

**Durability:** 500 mating cycles minimum (CX--,TX--, QX-- contacts)  
 100 mating cycles minimum (EXI-- contacts)  
**Bayonet Coupling Torque:** Per VG95234  
**Vibration:** Cat 1B according to EN61373

**Min. Retention force of the contact in the insulator:**  
 70N for contacts #16  
 90N for contacts #12  
 200N for contacts #CX--, #TX--, #QX-- and #EXI--

## ELECTRICAL PERFORMANCE

**Insulation Resistance:** 5000 MOhm  
**Rated and test voltage:** consult single layout

**Contact Current Rating:** see contacts table

Layout	Shell Size	Contacts Size	No of Contacts	Current		Voltage	
				Rated Amps	Max * Amps	Rated	Test
18PM12-1	18	#M12	1	Consult single contacts		200Vac 250Vdc	1000Vac
32PM12-2	32	#M12	2	Consult single contacts		200Vac 250Vdc	1000Vac
32PM12-3	32	#M12	3	Consult single contacts		200Vac 250Vdc	1000Vac
32PM12-4	32	#M12	4	Consult single contacts		200Vac 250Vdc	1000Vac
290PM12-7	290	#M12	7	Consult single contacts		200Vac 250Vdc	1000Vac
290PM12-13	290	#M12	7	Consult single contacts		200Vac 250Vdc	1000Vac
		#12	6	23A	41	500Vac 700Vdc	2000Vac
290PM12-13	290	#M12	Consult factory for new development				
		#12					
		#16					

\* Applicable for short time

# FRCIRM12 COMPONENTS DESCRIPTION

## PANEL MOUNTED CONNECTOR

---

**Flange** - holds the insert and incorporates an alignment key to position the insert. The Flange accommodates either the socket or pin insert to reverse gender. Bayonet Coupling ramps provide cam action for coupling and uncoupling with the plug connectors. Stainless steel pins, at the top of the ramps, ensure positive locking and long service life.

**Insert (pin or socket)** - removable, orientable, retains the contacts and can be used in either Flange or plugshells.

**Contacts (pin or socket)** - suitable to be used with the wire conductors.

**Retaining Ring** - retains the insert into the shell.



## PLUG CONNECTOR

---

**Coupling nut** - Provides cam force when mating and un-mating mechanical system for coupling and uncoupling of the connectors.

**Plugshell** - Holds the insert and incorporates an alignment key to position the insert. The plugshell accommodates either the socket or pin insert to reverse gender.

**Insert (pin or socket)** - Removable, orientable, retains the contacts and can be used in either Flange or plugshells.

**Contacts (pin or socket)** - Suitable to be used with the wire conductors.

**Retaining Ring** - Retains the insert into the shell.



# FRCIRM12 CONNECTOR ORDER CODE

FR	CIR	06	R	32PM12	-4	P	W	TXX	VO-XXXX
----	-----	----	---	--------	----	---	---	-----	---------

**Prefix**

FR Flame retardant

**Connector Series**

CIR Bayonet Coupling

**Shell Style**

030FF Rear panel mount receptacle, rear thread

030FP Front panel mount receptacle, rear thread

06 Straight plug connect

08 Right angle (90°) plug connector

**Environmental Class**

Class is based on backshell type, Sealing capability & Accessories

R With grommet

A Without grommet, just for Crimpable version

**Connector size**

18PM12 Plastic insert, size 18,

32PM12 Plastic insert, size 32,

290PM12 Plastic insert, size 290,

**Insert Arrangement**

1 1 cavity for M12 contact

2 2 cavities for M12 contacts

3 3 cavities for M12 contacts

4 4 cavities for M12 contacts

7 7 cavities for M12 contacts

13 13 cavities, 7 for for M12 contacts and 6 for size 12

xx consult factory for new development

**Contact Gender**

P Male contacts

S Female contacts

**Alternative insert rotation**

N No digit normal position

W

X

**Plating Code**

T39 Black epoxyurethanic varnish – RoHS compliant - 500H salt spray resistant - non-conductive

T891 Black hard anodizing – RoHS compliant - 1000H salt spray resistant - non-conductive

T108 Zinc/cobalt Ecoblack – RoHS compliant - 200H salt spray resistant - conductive

T240 Blue Zn/Ni – Conductive - RoHS compliant - 500H salt spray resistant - conductive

**Modification**

VO Contacts not supplied

xxxx According to custom application, consult factory

# FRCIRM12 CONTACTS ORDER CODE

TX I M12 P 2 XX

## Number of inner contact

- CX** 1 pole (coaxial cable)
- TX** 2 poles (WTB application usually)
- QX** 4 poles (MVB and 100 Mbps Ethernet application usually)
- EX** 8 poles (1 and 10 Gigabit Ethernet application usually)

## Contacts type

- I** Inspectionable
- Blank** for crimped version not inspectionable

## Series

- M12** useful for FRCIRM12 connector Version
- Blank** for CXI contacts series (only) but still useful for FRCIRM12 connector version

## Contact Gender

- P** Male contacts
- S** Female contacts

## Cable Diameter

- Inspectionable version:
- 2** up to Ø 8.8
  - 4** up to Ø 11
- Crimpable version: consult factory  
CXI version: consult factory

## Modification

- VO** Inner contacts not supplied
- xx** According to custom application, consult factory



## FRCIRM12 HARNESSING ORDER CODE

CAB	-017	-001	2	XX
-----	------	------	---	----

**Prefix**

**CAB** Harnessing

**Date**

Those digit gave detail of year of harnessing definition

**Style**

Those digit gave detail of harnessing definition customized (consult factory)

**Length**

Harnessing length in meter

**Modification**

**xx** Special feature according to custom application, consult factory



### Contacts harnessing procedure;

We kindly recommend to follow the below listed specification if you have to assemble M12 contacts:

- TXM12-- SV1486
- TXIM12-- SV1502
- QXM12-- SV1485
- QXIM12-- SV1501
- EXIM12-- SV1498

# FRCIRM12 INSERT ARRANGEMENT

## INSERT LAYOUTS

Front Inserts View

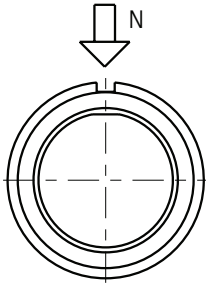

Male Insert

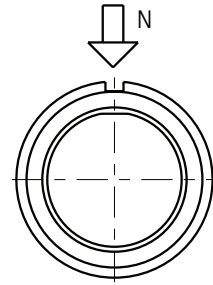

Female Insert

Layout	Shell	Contact Type	N° of contacts	Polarization
18PM12-1	18	#M12	1	N.A.

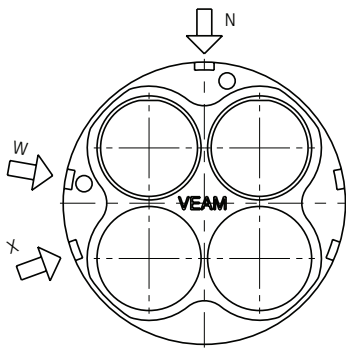

Male Insert

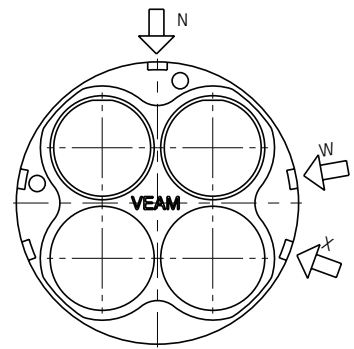

Female Insert

Layout	Shell	Contact Type	N° of contacts	Polarization
32PM12-2	32	#M12	2	N
				W (80°)
				X (110°)

# FRCIRM12 INSERT ARRANGEMENT

## INSERT LAYOUTS

Front Inserts View

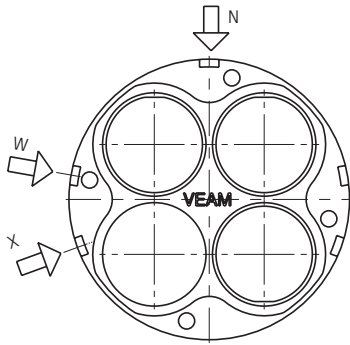

Male Insert

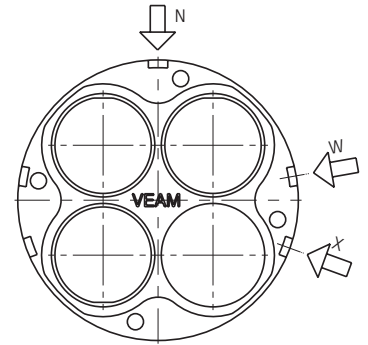

Female Insert

Layout	Shell	Contact Type	N° of contacts	Polarization
32PM12-3	32	#M12	3	N
				W (80°)
				X (110°)

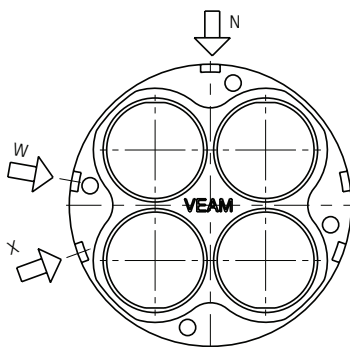

Male Insert

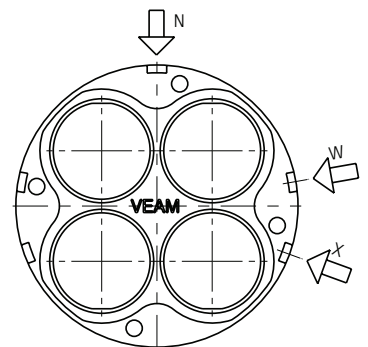

Female Insert

Layout	Shell	Contact Type	N° of contacts	Polarization
32PM12-4	32	#M12	4	N
				W (80°)
				X (110°)

# FRCIRM12 INSERT ARRANGEMENT

## INSERT LAYOUTS

Front Inserts View

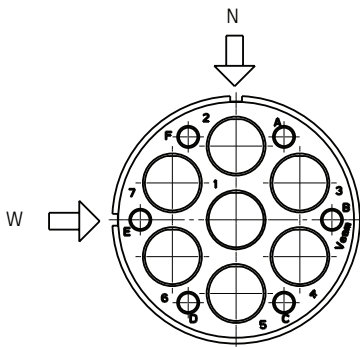

Male Insert

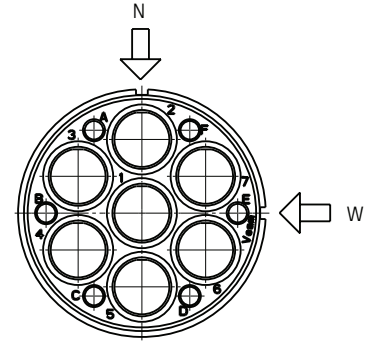

Female Insert

Layout	Shell	Contact Type	N° of contacts	Polarization
290PM12-7	290	#M12	7	N
				W (90°)

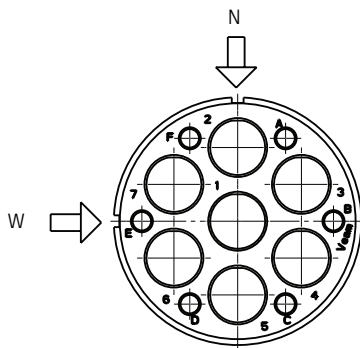

Male Insert

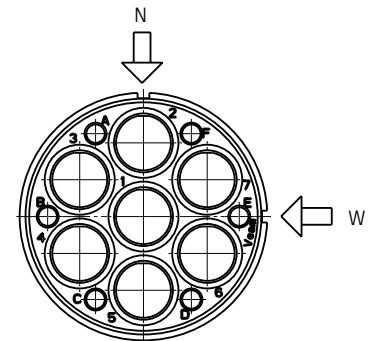

Female Insert

Layout	Shell	Contact Type	N° of contacts	Polarization
290PM12-13	290	#M12	7	N
		#12	6	W (90°)

# FRCIRM12 INSERT ARRANGEMENT

## INSERT LAYOUTS

Please contact Factory for new contacts layout based on different shell size

Layout	Shell	Contacts Type	N° of contacts	Polarization
XXPM12-xx	xx	#M12	t.b.d.	t.b.d.
		#12		
		#16		



Please contact Factory for new insert layout based on different shell size 290

Layout	Shell	Contacts Type	N° of contacts	Polarization
290PM12-xx	290	#M12	t.b.d.	t.b.d.
		#12		
		#16		

# FRCIRM12 CONTACTS

## CXI--

Male contact to be used in connector with male insulator

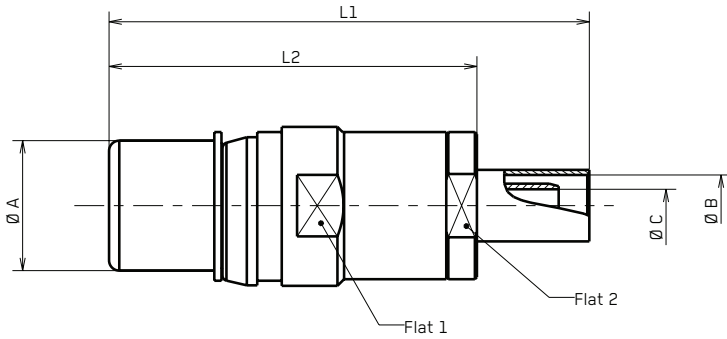

Male Part number	Size	Cable size	L1 Approx.	L2 Approx.	Ø A ±0,02	Ø B ±0,01	Ø C ±0,01	Flat 1	Flat 2	Max innex contact current
CXI-P-058	#M12	RG058	47	36	12,72	6	3,2	14,5	13	5 Amps
CXI-P-213	#M12	RG213	48	36	12,72	11	7,4	14,5	13	5 Amps

Notes: 1- for different cable diameter please contact factory

## CXI--

Female contact to be used on connector with female insulator.

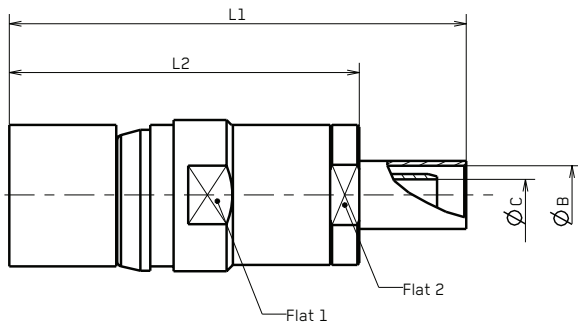

Female Part number	Size	Cable size	L1 Approx.	L2 Approx.	Ø B ±0,01	Ø C ±0,01	Flat 1	Flat 2	Max innex contact current
CXI-S-058	#M12	RG058	47	36	6	3,2	14,5	13	5 Amps
CXI-S-213	#M12	RG213	48	36	11	7,4	14,5	13	5 Amps

Notes: 1- for different cable diameter please contact factory

## FRCIRM12 CONTACTS

### TX--

Male contact to be used in connector with male insulator.  
This contact is suitable (with appropriate cable) for WTB applications.

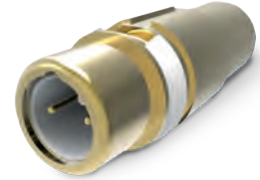
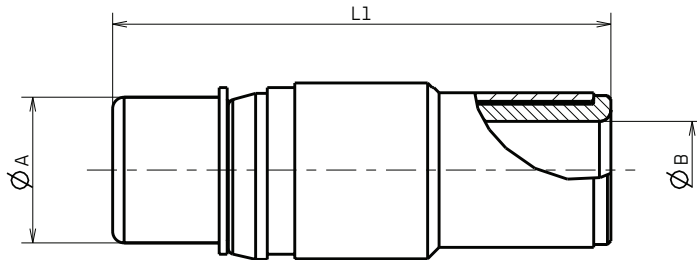

Male Part number	Size	Cable Type	Inner contacts cross section	Max dia. Single leader	L1 Approx.	Ø A ±0,02	Ø B ±0,1	Max inner current
TXM12P-1	#M12	Consult factory	AWG22 0,5sqmm 0,75sqmm	Ø 3mm	44,15	12,72	8,5	10 Amps
TXM12P-2	#M12				44,15	12,72	9	10 Amps
TXM12P-3	#M12				44,15	12,72	7,7	10 Amps
TXM12P-4	#M12				43	12,72	13,45	10 Amps

Notes: 1- for different cable diameter please contact factory

### TX--

Female contact to be used in connector with female insulator.  
This contact is suitable (with appropriate cable) for WTB applications.

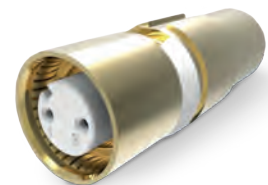
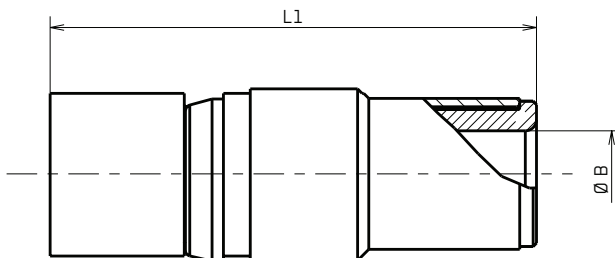

Female Part number	Size	Cable Type	Inner contacts cross section	Max dia. Single leader	L1 Approx.	Ø B ±0,1	Max inner current
TXM12S-1	#M12	Consult factory	AWG22 0,5sqmm 0,75sqmm	Ø 3mm	44,15	8,5	10 Amps
TXM12S-2	#M12				44,15	9	10 Amps
TXM12S-3	#M12				44,15	7,7	10 Amps
TXM12S-4	#M12				43	13,45	10 Amps

Notes: 1- for different cable diameter please contact factory

# FRCIRM12 CONTACTS

## TXI--

Male contact to be used in connector with male insulator.  
This contact is suitable (with appropriate cable) for WTB applications.

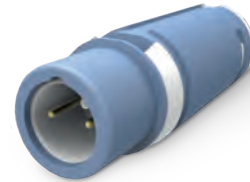
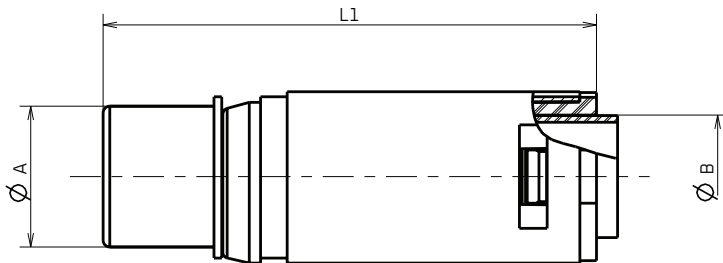

Male Part number	Size	Cable Type	Inner contacts cross section	Max dia. Single leader	L1 Approx.	Ø A ±0,02	Ø B ±0,1	Max inner current
TXIM12P-1	#M12	Consult factory	AWG22 0,5sqmm	Ø 3mm	44,65	12,72	11	10 Amps
TXIM12P-2	#M12		0,75sqmm		44,65	12,72	8,8	10 Amps

Notes: 1- for different cable diameter please contact factory

## TXI--

Female contact to be used on connector with female insulator.  
This contact is suitable (with appropriate cable) for WTB applications.

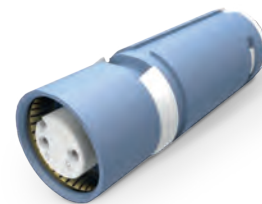
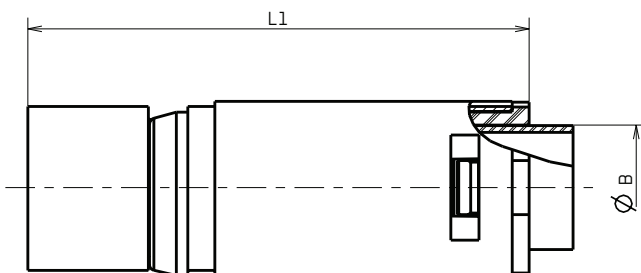

Female Part number	Size	Cable Type	Inner contacts cross section	Max dia. Single leader	L1 Approx.	Ø B ±0,1	Max inner current
TXM12S-1	#M12	Consult factory	AWG22 0,5sqmm	Ø 3mm	44,65	11	10 Amps
TXM12S-2	#M12		0,75sqmm		44,65	8,8	10 Amps

Notes: 1- for different cable diameter please contact factory

# FRCIRM12 CONTACTS

## QX--

Male contact to be used in connector with male insulator.  
 This contact is suitable (with appropriate cable) for MVB and Class D (according to ISO/IEC 11801) applications.

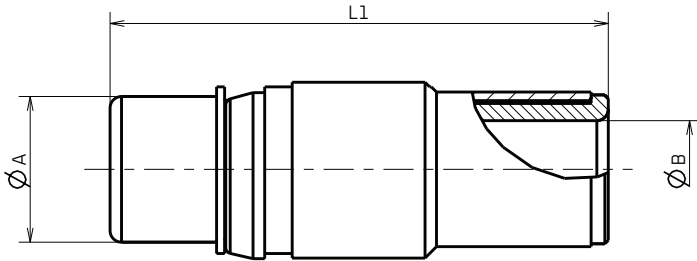

Male Part number	Size	Cable Type	Inner contacts cross section	Max dia. Single leader	L1 Approx.	Ø A ±0,02	Ø B ±0,1	Max inner current
QXM12P-1	#M12	Consult factory	AWG22 0,34sqmm 0,5sqmm	Ø 2,2mm	44,15	12,72	7,7	10 Amps
QXM12P-2	#M12				44,15	12,72	8,5	10 Amps
QXM12P-3	#M12				44,15	12,72	6,7	10 Amps

Notes: 1- for different cable diameter please contact factory

## QX--

Female contact to be used in connector with female insulator.  
 This contact is suitable (with appropriate cable) for MVB and Class D (according to ISO/IEC 11801) applications.

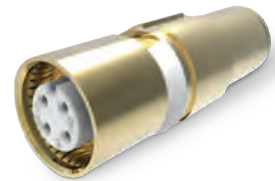
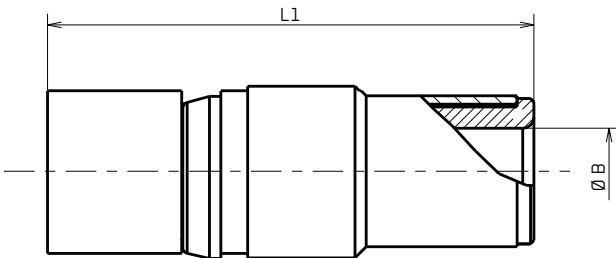

Female Part number	Size	Cable Type	Inner contacts cross section	Max dia. Single leader	L1 Approx.	Ø B ±0,1	Max inner current
QXM12S-1	#M12	Consult factory	AWG22 0,34sqmm 0,5sqmm	Ø 2,2mm	44,15	7,7	10 Amps
QXM12S-2	#M12				44,15	8,5	10 Amps
QXM12S-3	#M12				44,15	6,7	10 Amps

Notes: 1- for different cable diameter please contact factory

## FRCIRM12 CONTACTS

### QXI--

Male contact to be used in connector with male insulator.  
This contact is suitable (with appropriate cable) for MVB and Class D (according to ISO/IEC 11801) applications.

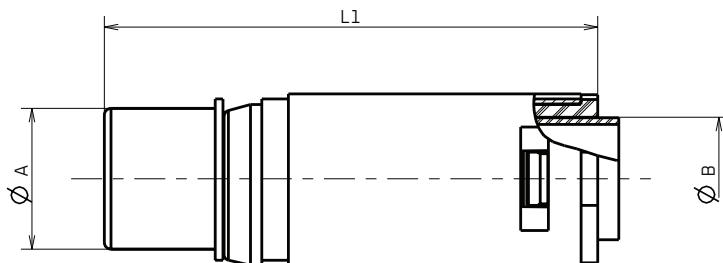

Male Part number	Size	Cable Type	Inner contacts cross section	Max dia. Single leader	L1 Approx.	Ø A ±0,05	Ø B ±0,1	Max inner current
QXIM12P-1	#M12	Consult factory	AWG22 0,34sqmm	Ø 2,2mm	44,65	12,7	7,7	10 Amps
QXIM12P-2	#M12		0,5sqmm		44,65	12,7	8,5	10 Amps

Notes: 1- for different cable diameter please contact factory

### QXI--

Female contact to be used in connector with female insulator.  
This contact is suitable (with appropriate cable) for MVB and Class D (according to ISO/IEC 11801) applications.

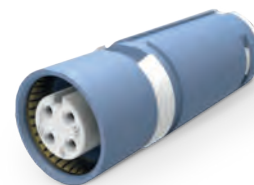
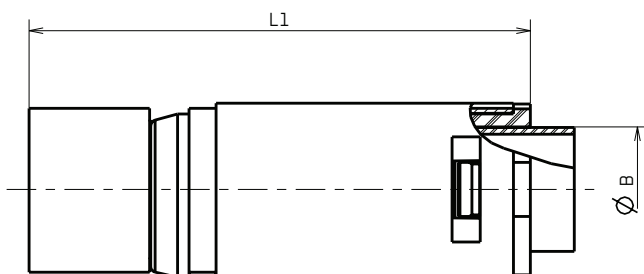

Female Part number	Size	Cable Type	Inner contacts cross section	Max dia. Single leader	L1 Approx.	Ø B ±0,1	Max inner current
QXIM12S-1	#M12	Consult factory	AWG22 0,34sqmm	Ø 2,2mm	44,65	11	10 Amps
QXIM12S-2	#M12		0,5sqmm		44,65	8,8	10 Amps

Notes: 1- for different cable diameter please contact factory

# FRCIRM12 CONTACTS

## EXI--

Male contact to be used in connector with male insulator.  
 This contact is suitable (with appropriate cable) for application up to Class FA according to ISO/IEC 11801

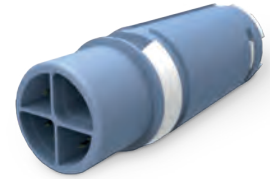
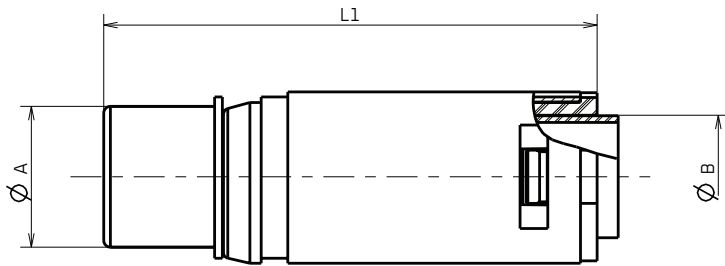

Male Part number	Size	Cable Type	Inner contacts cross section	Max dia. Single leader	L1 Approx.	Ø A ±0,05	Ø B ±0,1	Max inner current
EXIM12P-1	#M12	Consult factory	AWG24	Ø 1,5mm	44,65	12,7	11	2 Amps
EXIM12P-2	#M12		AWG23		44,65	12,7	8,8	2 Amps

Notes: 1- for different cable diameter please contact factory

## EXI--

Female contact to be used in connector with female insulator.  
 This contact is suitable (with appropriate cable) for application up to Class FA according to ISO/IEC 11801

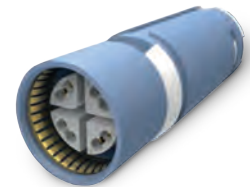
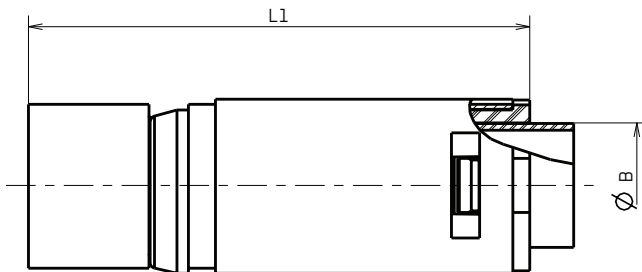

Female Part number	Size	Cable Type	Inner contacts cross section	Max dia. Single leader	L1 Approx.	Ø B ±0,1	Max inner current
EXIM12S-1	#M12	Consult factory	AWG24	Ø 1,5mm	44,65	11	2 Amps
EXIM12S-2	#M12		AWG23		44,65	8,8	2 Amps

Notes: 1- for different cable diameter please contact factory

# FRCIRM12 CONTACTS

## 51511-12-- CONTACTS

Female contact to be used in connector with female insulator.

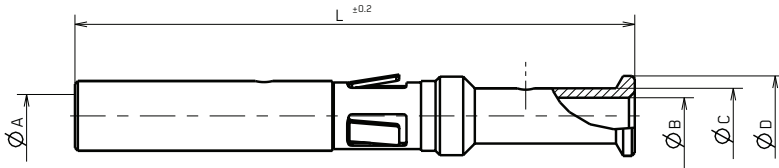

Male Part number	Size	Wire Size		L	Ø A	Ø B	Ø C	Ø D	Rated current	Max current
		mm <sup>2</sup>	AWG							
51511-12T12	#12	2.5-3.0	12	38,5	2,48	2,5	3.8	5.5	23 Amps	41 Amps
51511-12-12T12	#12	0.5-0.75	20	38,5	2,48	1,2	2.6	5.5	23 Amps	41 Amps
51511-12-20T12	#12	1.0-2.0	16	38,5	2,48	2	3.8	5.5	23 Amps	41 Amps
51511-12-30T12	#12	4		38,5	2,48	3	4.8	5.5	23 Amps	41 Amps
51511-12-38T12	#12	6	10	38,5	2,48	3,6	4.8	5.5	23 Amps	41 Amps

Notes: 1- for different cable size please contact factory

## 51511-12-- CONTACTS

Male contact to be used in connector with male insulator.

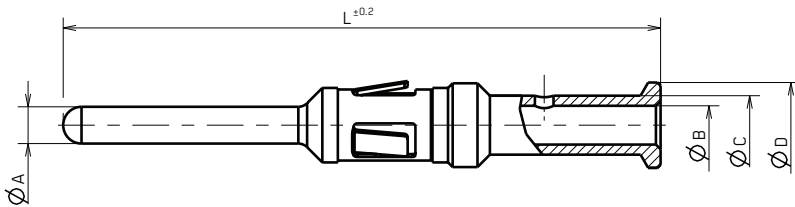

Male Part number	Size	Wire Size		L	Ø A	Ø B	Ø C	Ø D	Max inner current	Max current
		mm <sup>2</sup>	AWG							
51511-12T12	#12	2.5-3.0	12	38,5	2,38	2,5	3.8	5.5	23 Amps	41 Amps
51511-12-12T12	#12	0.5-0.75	20	38,5	2,38	1,2	2.6	5.5	23 Amps	41 Amps
51511-12-20T12	#12	1.0-2.0	16	38,5	2,38	2	3.8	5.5	23 Amps	41 Amps
51511-12-30T12	#12	4		38,5	2,38	3	4.8	5.5	23 Amps	41 Amps
51511-12-38T12	#12	6	10	38,5	2,38	3,6	4.8	5.5	23 Amps	41 Amps

Notes: 1- for different cable size please contact factory

# FRCIRM12 RECEPTACLE

## FRCIR030R18PM12-1XTXX-D661-X FRCIR030R18PM12-1XTXX-D700-X

Rear panel mounting receptacle with threaded fixing holes, grommet and backshell with metric thread.

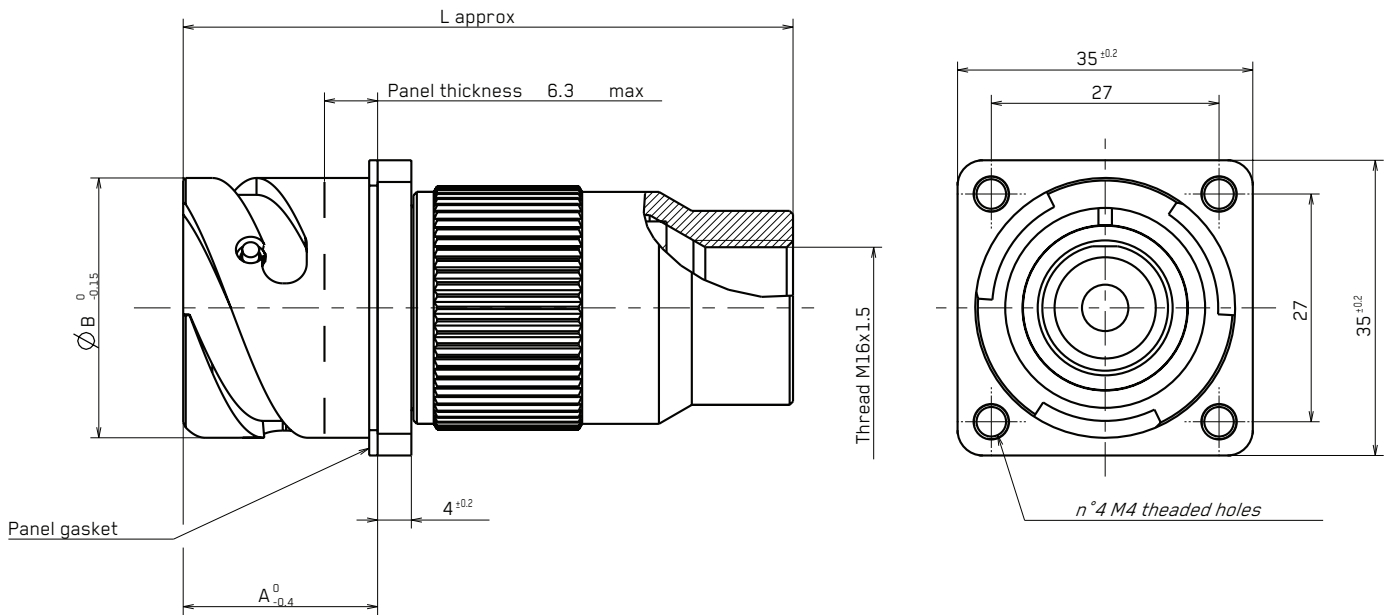

Part number	L Approx.mm	Wire Size mm	A +0,4-0	Ø B +0 -0,15	Thread
--- D661	73	Range 8-11	23,05	30,8	M16x1,5
--- D661-1	73	Range 6-8	23,05	30,8	M16x1,5
--- D700-2	73	Range 12-14	23,05	30,8	M20x1,5

Notes: 1- for different version please contact factory

# FRCIRM12 PLUG

**FRCIR06RGGP18PM12-1XTXX-D661-X**

**FRCIR06RGGP18PM12-1XTXX-D700-X**

Plug connector with short rubber covered coupling nut, grommet and backshell with metric thread.

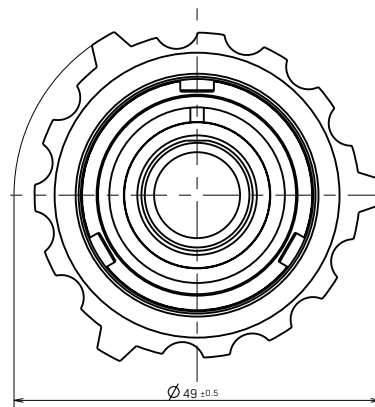
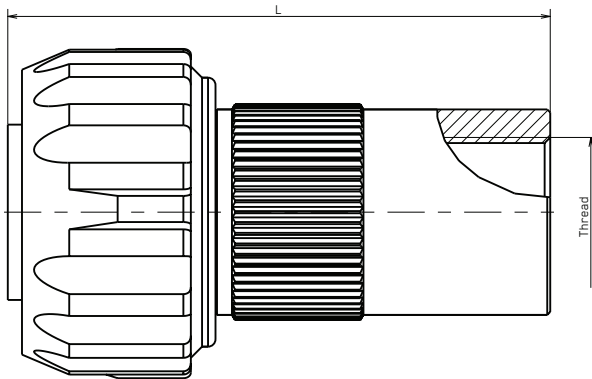
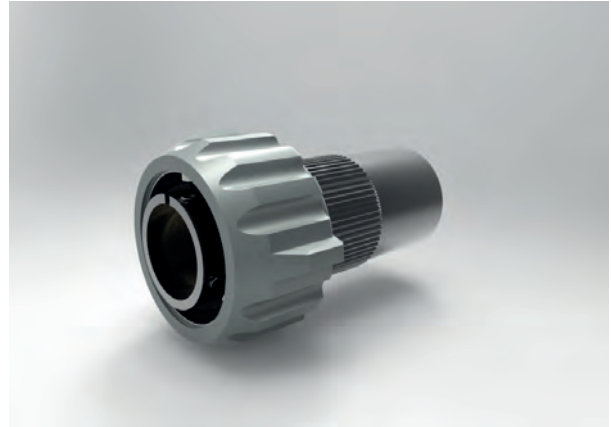

Part number	L Approx.mm	Wire Size mm	Thread
--- D661	73	Range 8-11	M16x1,5
--- D661-1	73	Range 6-8	M16x1,5
--- D700-2	73	Range 12-14	M20x1,5

Notes: 1- for different version please contact factory

# FRCIRM12 RECEPTACLE

## FRCIR030AFP32PM12-XXTXX-D552

Front panel mounting receptacle without grommet.  
 panel gasket not provided with connector  
 (Inspectional contacts version are not recommended).

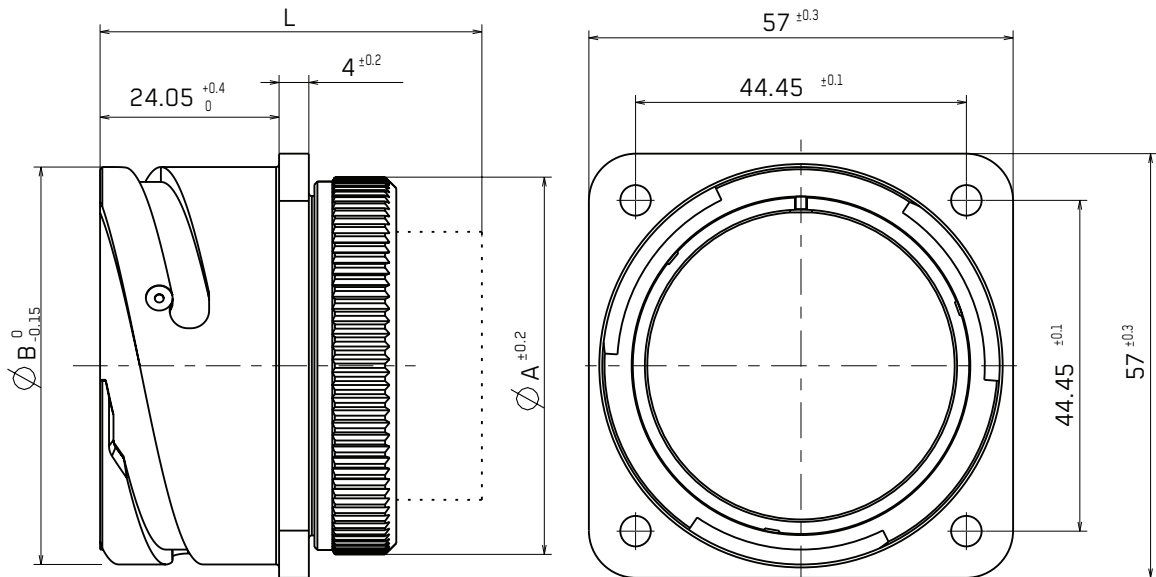

Part number	L Approx.mm	A ±0.2	Ø B +0 -0,15	Data transmission Contacts
--32PM12-2--	51.3	50.7	53.4	Up to 2
--32PM12-3--	51.3	50.7	53.4	Up to 3
--32PM12-4--	51.3	50.7	53.4	Up to 4

Notes: 1- for different version please contact factory

# FRCIRM12 RECEPTACLE

## FRCIR030AFSA32PM12-XXTXX-D552

Front panel mounting receptacle without grommet.  
 panel gasket not provided with connector and flange  
 with 4 countersunk mounting holes.  
 (Inspectional contacts version are not recommended).

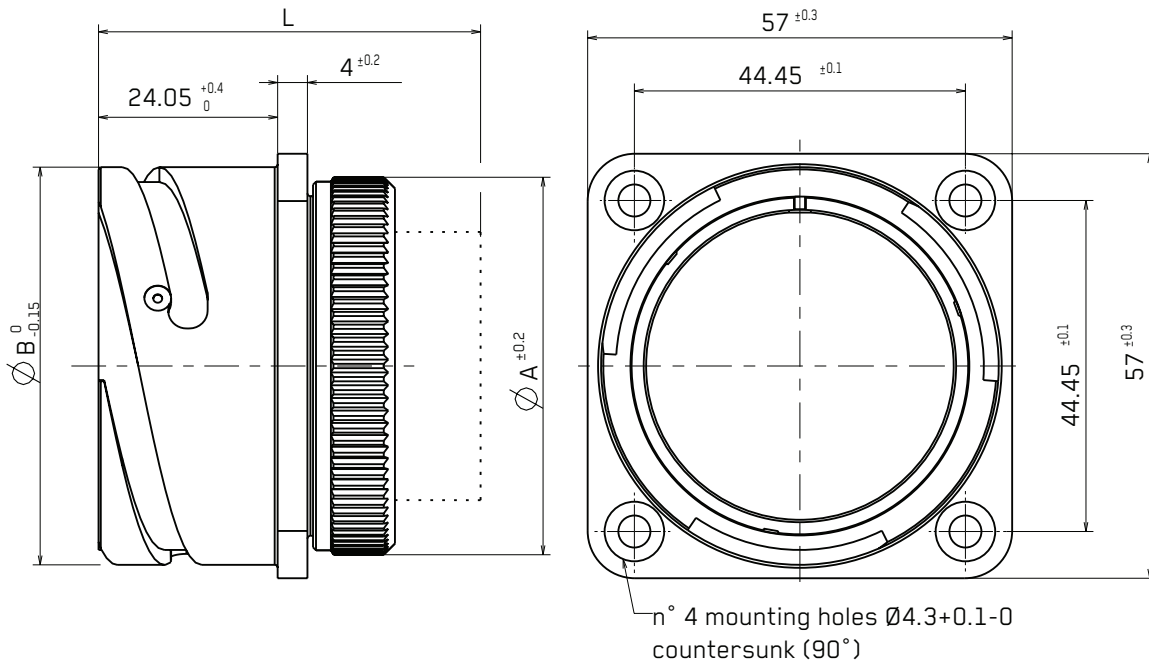

Part number	L Approx.mm	A ±0.2	Ø B +0 -0,15	Data transmission Contacts
--32PM12-2--	51.3	50.7	53.4	Up to 2
--32PM12-3--	51.3	50.7	53.4	Up to 3
--32PM12-4--	51.3	50.7	53.4	Up to 4

Notes: 1- for different version please contact factory

# FRCIRM12 RECEPTACLE

- FRCIR030RFF32PM12-XXTXX-D662-X**
- FRCIR030RFF32PM12-XXTXX-D594-X**
- FRCIR030RFF32PM12-XXTXX-D574-X**

Rear panel mounting receptacle with grommet and panel gasket with special termination for FS rubber tube.

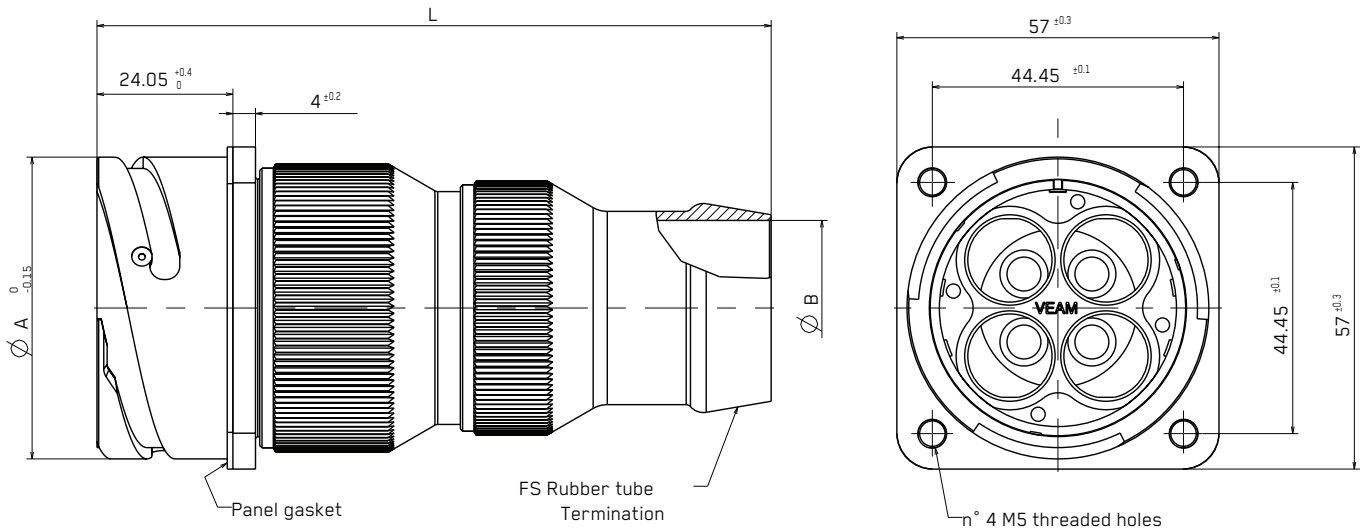

Part number	$\varnothing A$ $+0 -0,15$	FS rubber tube			Wire size range			Data transmission Contacts
		D574	D594	D662	None	ZM	ZM1	
--32PM12-2--	53.4	FS 2520 $\varnothing B - 18+0-0,2$ L-135 Approx.	FS2924 $\varnothing B - 22+0-0,5$ L-130 Approx.	FS 3833 $\varnothing B 31+0,2-0$ L-120 Approx.	5-7			Up to 2
--32PM12-3--					7,5-9			Up to 3
--32PM12-4--					6,5-8.5			Up to 4

Notes: 1- for different version please contact factory

# FRCIRM12 RECEPTACLE

## FRCIR030RFP32PM12-XTXX-VO-G1-X

Front panel mounting receptacle with grommet and panel gasket.

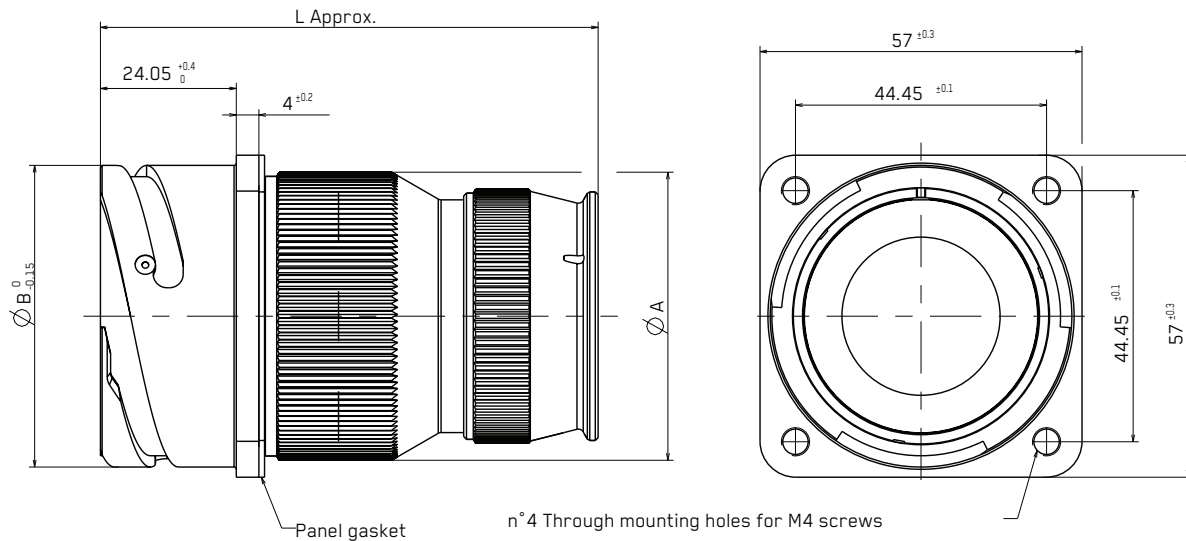

Part number	Ø A ±0,2	Ø B +0-0,15	L Approx.	Wire size range			Data transmission Contacts
				None	ZM	ZM1	
--32PM12-2--	51	53,4	88,1	5-7			Up to 2
--32PM12-3--				7,5-9			Up to 3
--32PM12-4--				6,5-8.5			Up to 4

Notes: 1- for different version please contact factory

# FRCIRM12 RECEPTACLE

## FRCIR030RFF32PM12-XXTXX-VO-G1-X

Rear panel mounting receptacle with grommet and panel gasket.

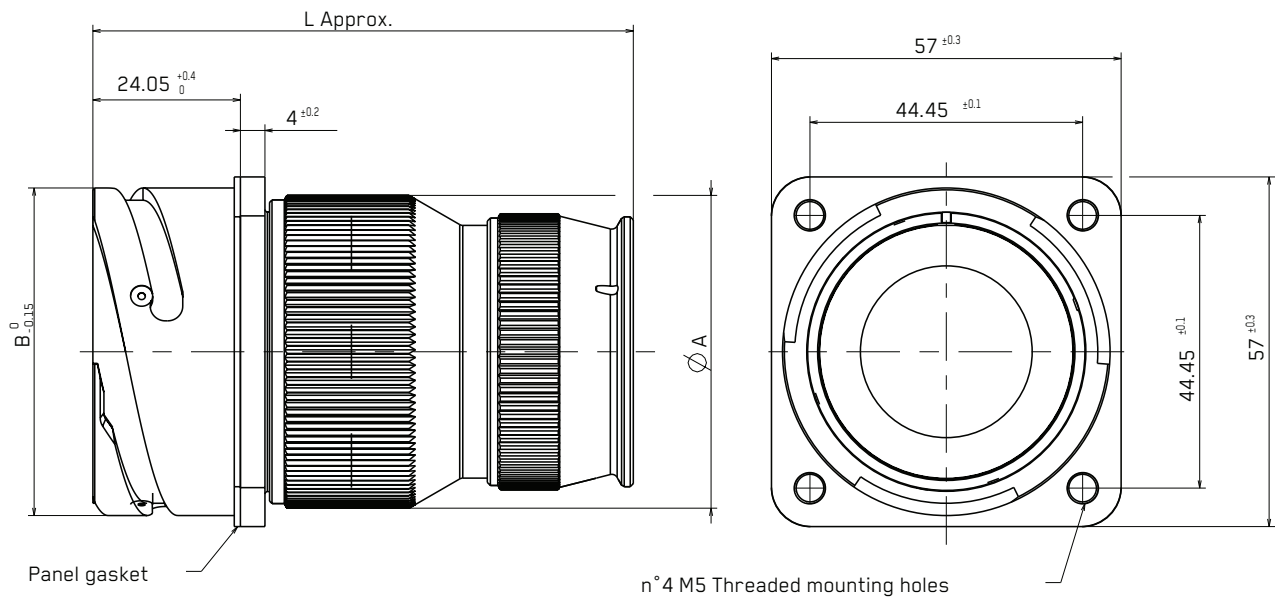

Part number	Ø A ±0,2	Ø B +0-0,15	L Approx.	Wire size range			Data transmission Contacts
				None	ZM	ZM1	
--32PM12-2--	51	53,4	88,1	5-7			Up to 2
--32PM12-3--				7,5-9			Up to 3
--32PM12-4--				6,5-8.5			Up to 4

Notes: 1- for different version please contact factory

# FRCIRM12 RECEPTACLE

## FRCIR030RFF32PM12- XXTXX-VO-D576-X

Rear panel mounting receptacle with grommet, panel gasket and backshell with metric female thread.

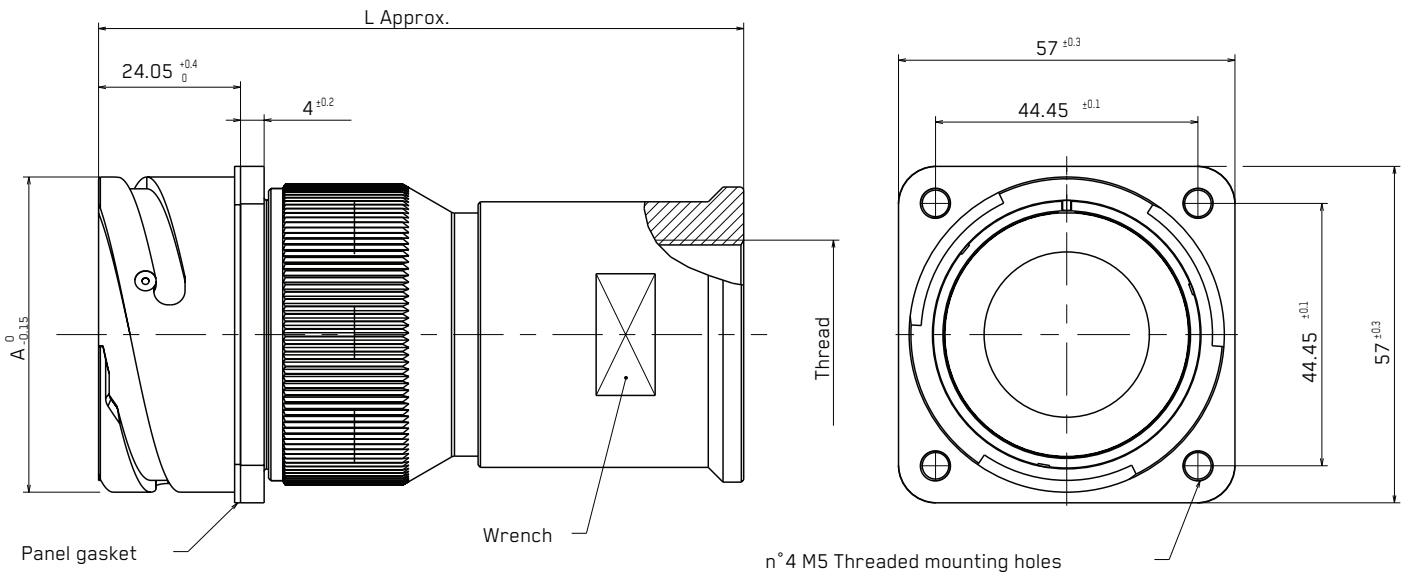
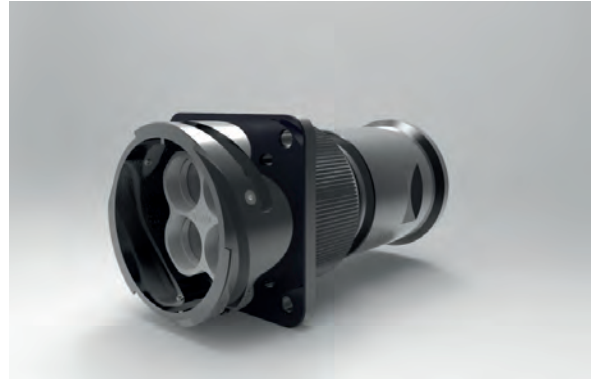

Part number	Ø A +0 -0,15	Metric Thread			Wire size range			Data transmission Contacts
		D576	D692	Dxxx	None	ZM	ZM1	
--32PM12-2--	53.4	Thread M32x1,5 Wrench 40	Thread M25x1,5 Wrench 40		5-7			Up to 2
--32PM12-3--					7,5-9			Up to 3
--32PM12-4--					6,5-8.5			Up to 4

Notes: 1- for different version please contact factory

# FRCIRM12 PLUG

- FRCIR06RGGP32PM12-XXTXX-D662-X**
- FRCIR06RGGP32PM12-XXTXX-D594-X**
- FRCIR06RGGP32PM12-XXTXX-D574-X**

Plug connector with short rubber covered coupling nut with grommet and special termination for FS rubber tube.

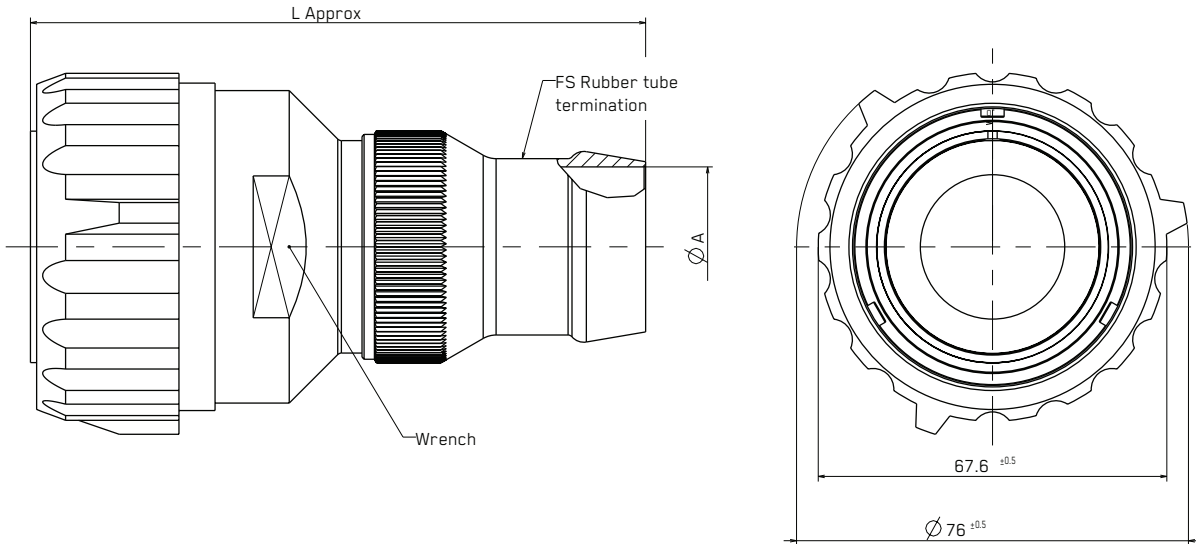
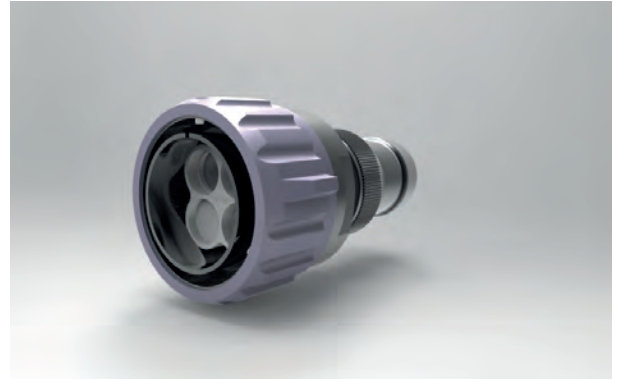

Part number	Wrench	FS rubber tube			Wire size range			Data transmission Contacts
		D574	D594	D662	None	ZM	ZM1	
--32PM12-2--	54	FS 2520 ØA - 18+0-0,2 L - 140 Approx.	FS2924 ØA - 22+0-0,5 L - 130 Approx.	FS 3833 ØA 31+0,2-0 L - 120 Approx.	5-7			Up to 2
--32PM12-3--					7,5-9			Up to 3
--32PM12-4--					6,5-8.5			Up to 4

Notes: 1- for different version please contact factory

# FRCIRM12 PLUG

**FRCIR06RGGP32PM12- XXTXX-VO-D576-X**

**FRCIR06RGGP32PM12- XXTXX-VO-D692-X**

Plug connector with short rubber covered coupling nut, grommet and backshell with metric female thread.

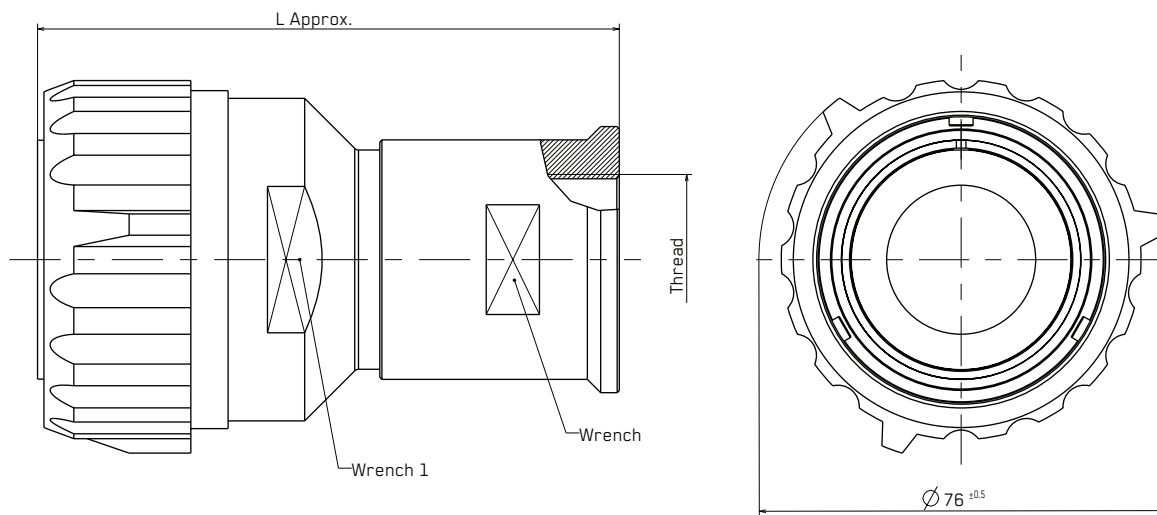
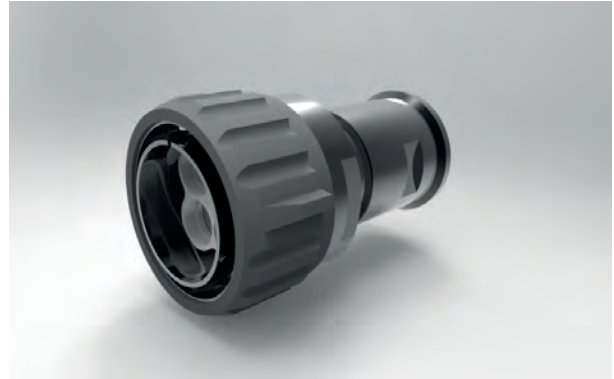

Part number	Wrench 1	FS rubber tube			Wire size range			Data transmission Contacts
		D576	D692	Dxxx	None	ZM	ZM1	
--32PM12-2--	54	Thread M32x1.5 L-110 Approx. Wrench - 40	Thread M25x1.5 L-125 Approx. Wrench - 40		5-7			Up to 2
--32PM12-3--					7,5-9			Up to 3
--32PM12-4--					6,5-8.5			Up to 4

Notes: 1- for different version please contact factory

# FRCIRM12 RECEPTACLE

## FRCIR290PM12-X-5C-030-AXXX-TXX

Rear panel mounting receptacle with grommet.

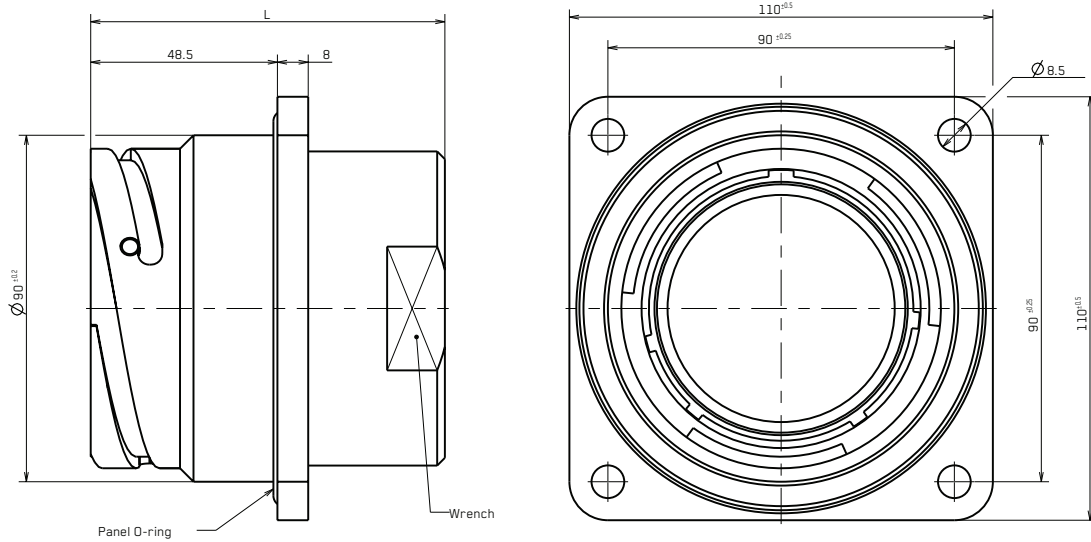
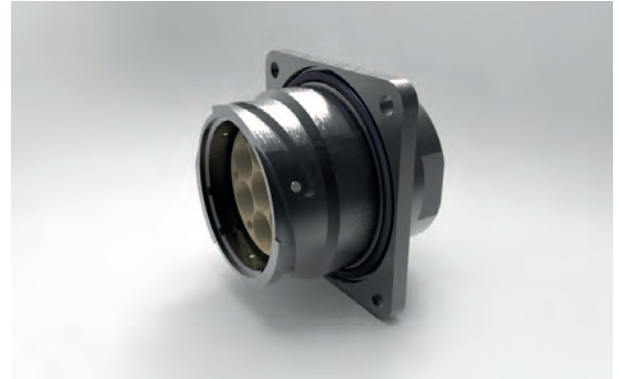

Part number	L Approx. mm	Contacts quantity		Wrench
		Data transmission	Size 12	
--290PM12-7--	92	Up to 7	N/A	75
--290PM12-13--	92	Up to 7	Up to 6	75

Notes: 1- for different version please contact factory

# FRCIRM12 RECEPTACLE

## FRCIR290PM12-X-5C-AXXX-TXX-MXX

Plug connector with rubber covered coupling nut, grommet and backshell with metric thread.

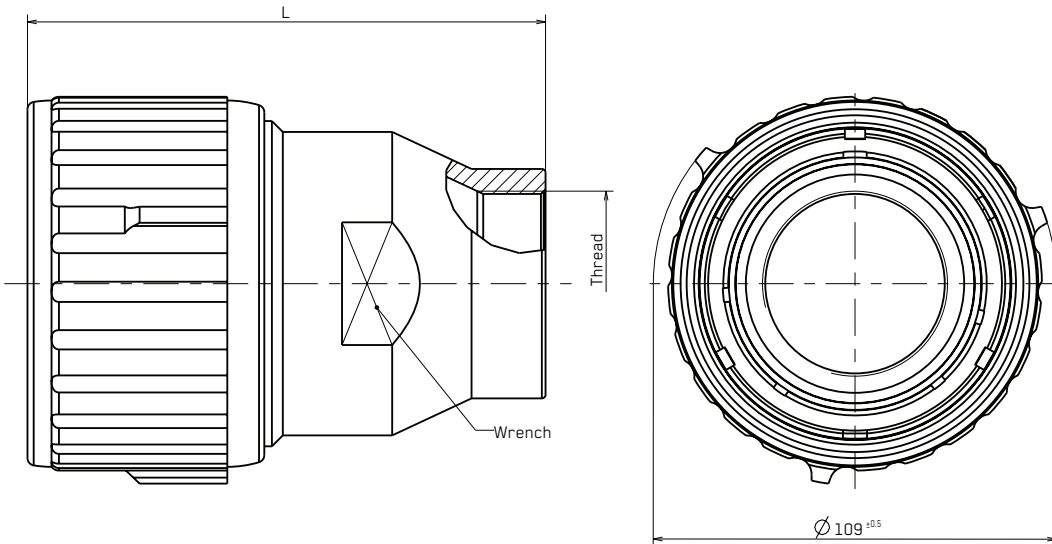
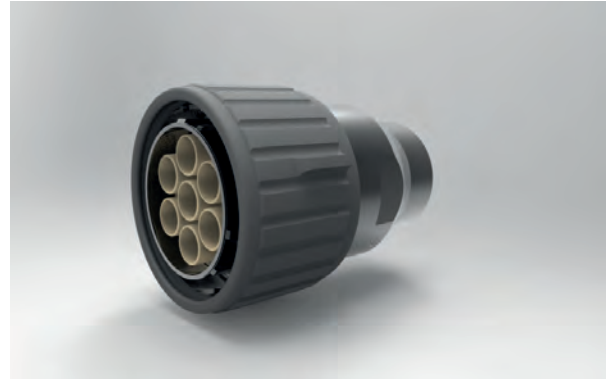

Part number	L. Approx. mm	Contacts quantity		Wrench	Thread
		Data transmission	Size 12		
--290PM12-7--	92	Up to 7	N/A	75	M50x1,5
--290PM12-13--	92	Up to 7	Up to 6	75	M50x1,5
Notes: 1- for different version please contact factory					

## ACCESSORY

### INSERT HOLE PLUG (#12 AND #16)

Rubber hole plug; used to close unused cavity of the insulator, consult following table

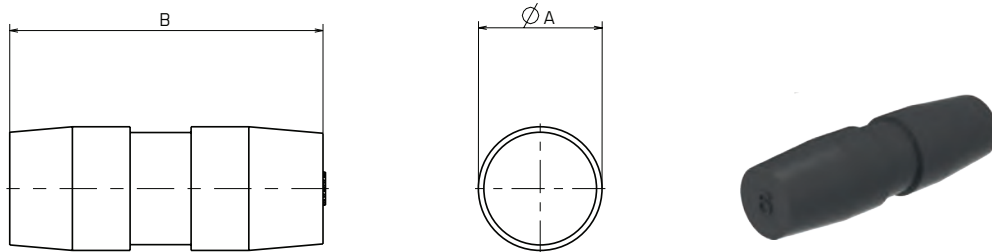

Part number	Contact size	Part number	ØA	B
51505-16	16	51605-16	3.7	13.5
51505-12	12	51605-12	5.4	15.5

### INSERT HOLE PLUG (#DATA TRANSMISSION) QXM12-OT

Plastic hole plug; used to close unused cavity of the insulator, consult following Drawing

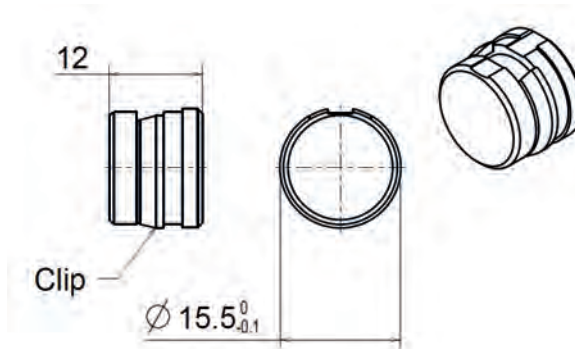

## ACCESSORY

### PANEL GASKET FOR FRONT MOUNTING RECEPTACLE

Used on Front panel mounting receptacle

Not conductive square gasket ("N" type).  
Chloroprene rubber.  
Protection degree: IP67

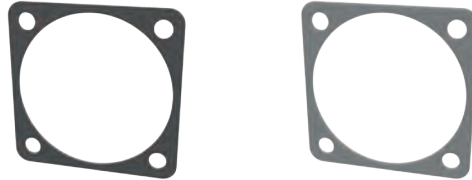

Conductive square gasket ("NS" type).  
Silicone rubber with conductive filler  
Protection degree: IP67

Size	A ±0.2	B +1 -0	C ±0.5	D +0.5 -0	"N" type (non-conductive)	"NS" type (conductive)
18	27	28.4	35	4.2	16954	16954/1
32	44.5	50.7	57	5.1	16959	16959/1
290	O-ring				40622	N/A

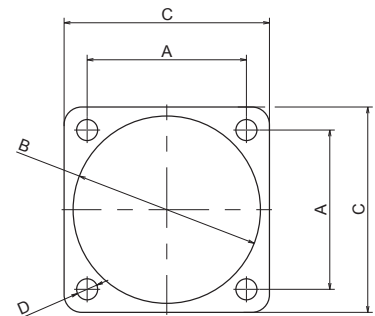

### PANEL GASKET FOR REAR MOUNTING RECEPTACLE

Used on Rear panel mounting receptacle

Not conductive square gasket ("N" type).  
Chloroprene rubber.  
Protection degree: IP67

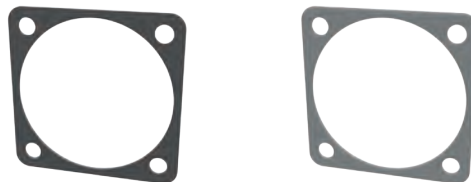

Conductive square gasket ("NS" type).  
Silicone rubber with conductive filler  
Protection degree: IP67

Size	A ±0.2	B +1 -0	C ±0.5	D +0.5 -0	"N" type (non-conductive)	"NS" type (conductive)
18	27	30.8	35	4.2	46739-18	46739-18/1
32	44.5	53.4	57	5.1	46739-32	46739-32/1
290	O-ring				40622	N/A

## ACCESSORY

### FRCIR-TF

Metal dust cap with stainless steel chain and Flame Retardant gasket  
Used on receptacle.

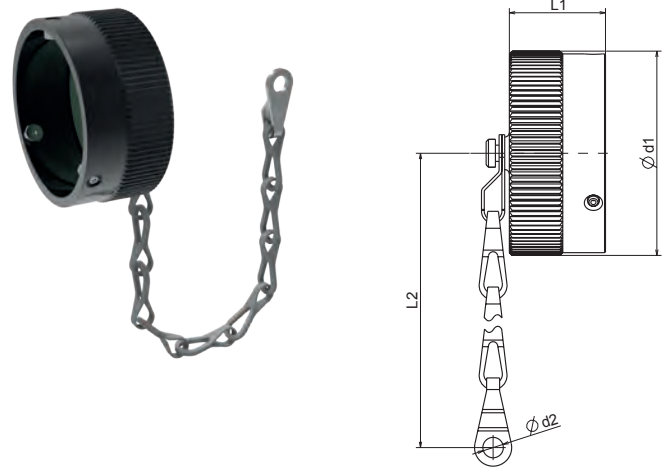

Part number	Used on connector size	Ø D1 max	Ø D2 +0,5-0	L1 ±0,2	L2 Approx.
FRCIR18TFTxx	18	37.5	4.4	20.7	127
FRCIR32TFTxx	32	61	5.6	20.7	190
FRCIR290TFTxx	290	95	8.5	28.2	285

### CIR-TV

Metal dust cap with stainless steel chain.  
Used on plug.

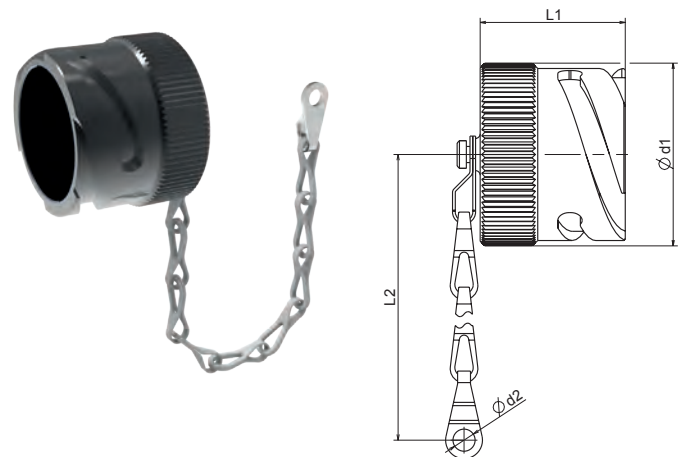

Part number	Used on connector size	Ø D1 max	Ø D2 +0,5-0	L1 ±0,2	L2 Approx.
FRCIR18TVTxx	18	37.5	4.4	20.7	127
FRCIR32TVTxx	32	61	5.6	20.7	190
FRCIR290TVTxx	290	92	8.5	60	285

## APPLICATION NOTES

### PANEL CUT-OUT

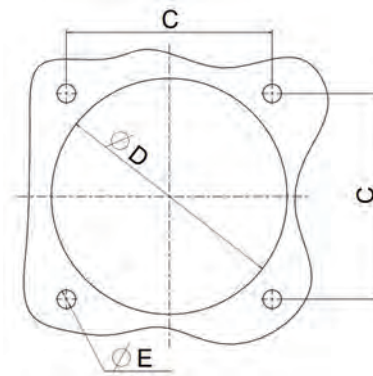

Rear mounting panel cut-out dimensions

Shell Size	C $\pm 0.1$	D $\pm 0.2$	$\varnothing E +0.2 -0$
18	27	31.7	4.5
32	44.5	54.3	5.5
290	90	91	8.5

Front mounting panel cut-out dimensions

Shell Size	C $\pm 0.1$	D $\pm 0.2$	$\varnothing E +0.2 -0$
18	27	26,5	3,4
32	44.5	48,5	4,5
290	90	91	8.5

### PANEL THICKNESS FOR REAR MOUNTING RECEPTACLE

Connector size	FRCIR06RGGP--
18	6.3 max
36	6.3 max
290	15 max

Notes: 1- for different version please contact factory

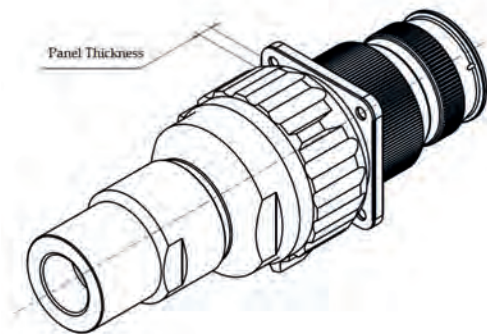

## APPLICATION NOTES

### BACKSHELL TORQUE VALUES

Thread	Max. Backshell to Connector Tightening Torque (Nm)
18	7.8
32	20.6
290	78.4
<p>The above values are based upon the most densely populated contact arrangements with cables at the maximum limit for the grommet. The values are for guidance only.</p>	

# FRCIRM12

## PRODUCT SAFETY INFORMATION

---

**THIS NOTE MUST BE READ IN CONJUNCTION WITH THE PRODUCT DATA SHEET/CATALOG. FAILURE TO OBSERVE THE ADVICE IN THIS INFORMATION SHEET AND THE OPERATING CONDITIONS SPECIFIED IN THE PRODUCT DATA SHEET/ CATALOG COULD RESULT IN HAZARDOUS SITUATIONS.**

### 1. MATERIAL CONTENT AND PHYSICAL FORM

Electrical connectors do not usually contain hazardous materials. They contain conducting and non-conducting materials and can be divided into two groups.

- a) Printed circuit types and low cost audio types which employ all plastic insulators and casings.
- b) Rugged, Fire Barrier and High Reliability types with metal casings and either natural rubber, synthetic rubber, plastic or glass insulating materials. Contact materials vary with type of connector and also application and are usually manufactured from either: Copper, copper alloys, nickel, alumel, chromel or steel. In special applications, other alloys may be specified.

### 2. FIRE CHARACTERISTICS AND ELECTRIC SHOCK HAZARD

There is no fire hazard when the connector is correctly wired and used within the specified parameters. Incorrect wiring or assembly of the connector or careless use of metal tools or conductive fluids, or transit damage to any of the component parts may cause electric shock or burns. Live circuits must not be broken by separating mated connectors as this may cause arcing, ionization and burning. Heat dissipation is greater at maximum resistance in a circuit. Hot spots may occur when resistance is raised locally by damage, e.g. cracked or deformed contacts, broken strands of wire. Local overheating may also result from the use of the incorrect application tools or from poor quality soldering or slack screw terminals. Overheating may occur if the ratings in the product Data Sheet/Catalog are exceeded and can cause breakdown of insulation and hence electric shock. If heating is allowed to continue it intensifies by further increasing the local resistance through loss of temper of spring contacts, formation of oxide film on contacts and wires and leakage currents through carbonization of insulation and tracking paths. Fire can then result in the presence of combustible materials and this may release noxious fumes. Overheating may not be visually apparent. Burns may result from touching overheated components.

### 3. HANDLING

Care must be taken to avoid damage to any component parts of electrical connectors during installation and use. Although there are normally no sharp edges, care must be taken when handling certain components to avoid injury to fingers. Electrical connectors may be damaged in transit to the customers, and damage may result in creation of hazards. Products should therefore be examined prior to installation/use and rejected if found to be damaged.

### 4. DISPOSAL

Incineration of certain materials may release noxious or even toxic fumes.

### 5. APPLICATION

Connectors with exposed contacts should not be selected for use on the current supply side of an electrical circuit, because an electric shock could result from touching exposed contacts on an unmated connector. Voltages in excess of 30 V ac or 42.5 V dc are potentially hazardous and care should be taken to ensure that such voltages cannot be transmitted in any way to exposed metal parts of the connector body. The connector and wiring should be checked, before making live, to have no damage to metal parts or insulators, no solder blobs, loose strands, conducting lubricants, swarf, or any other undesired conducting particles. Circuit resistance and continuity check should be made to make certain that there are no high resistance joints or spurious conducting paths. Always use the correct application tools as specified in the Data Sheet/Catalog. Do not permit untrained personnel to wire, assemble or tamper with connectors. For operation voltage please see appropriate national regulations.

### IMPORTANT GENERAL INFORMATION

(i) Air and creepage paths/Operating voltage. The admissible operating voltages depend on the individual applications and the valid national and other applicable safety regulations. For this reason the air and creepage path data are only reference values. Observe reduction of air and creepage paths due to PC board and/or harnessing.

(ii) Temperature

All information given are temperature limits. The operation temperature depends on the individual application.

(iii) Other important information

Cannon continuously endeavors to improve their products. Therefore, Cannon products may deviate from the description, technical data and shape as shown in this catalog and data sheets.

All data subject to change without notice.

# ADDITIONAL VEAM SOLUTIONS FOR RAIL INFRASTRUCTURE AND ROLLING STOCK APPLICATIONS

## CIR/FRCIR Series



- Available with 1-159 poles, 256 layouts, 2,000 matching cycles
- Flame retardant (EN45545 HL3 - NFPA 130)
- Aluminium shells up to 500h salt spray resistance
- Stainless steel & marine bronze available



## DSR Series

- Double start ratchet threaded coupling mechanism with 5 Keyways
- Flame retardant (EN45545 HL3 - NFPA130)
- High shock resistance

## VBN Series



- Available with 4-70 poles, 15 layouts
- Compliant to mass transit specification NF F 61-030. Approved & qualified by SNCF & RATP
- Flame retardant UL94V-0 & NFF thermoplastic insert
- Easy contact insertion and extraction 2,000 Mating Cycles



## Power Plate Series

- 2-3-4 pole versions, highly customizable according cable, current and voltage requirements
- Operating voltage according to EN50124-1
- Fast and easy coupling system with two screws or with latch mechanism

## CIR290 Series



- Available with 3 to 101 poles, from 7.5 to 350 A, 2,000 mating cycles
- Flame retardant (EN45545 HL3 - NFPA 130)
- Aluminium shells up to 500h salt spray resistance



## VRPC Series

- Available with 3,6,12 way layouts, machined or stamped contacts
- Smoke & fire resistance per NFF16-101 & NFF16-102
- IP20 or IP67
- Rear removable cable support or Rear backshells

## HTB Series



- High Temperature Bayonet connector, tested at 800°C for 30 minutes
- Exceeds the standard ISO 834-1
- Creates a REI 0 fire barrier according EN13501-2 / EN 1363-1



## CIR Fiber Optic Series

- Available with 4 to 22 multimode or singlemode fibers
- Supports communication speed up to beyond 10 Gbps
- Customized harnessing service on request

Connect with your ITT Veam representative today  
or visit us at [www.ittcannon.com](http://www.ittcannon.com)

## Connect with the experts

ITT's Veam brand is a world leader in the design and manufacture of highly engineered connector solutions for multiple end markets.



ENGINEERED FOR LIFE

### North America

56 Technology Drive  
Irvine, CA 92618, USA  
Phone 1.800.854.3028

100 New Wood Road  
Watertown, CT 06795, USA  
Phone: +1.860.274.9681

### Europe

Italy  
Corso Europa 41/43  
I - 20020 Lainate (MI) Italy  
Phone: +39.02938721

Germany  
Cannonstrasse 1  
D - 71384 Weinstadt, Germany  
Phone: +49.7151.699.0

### Asia

Tuopandun Industrial Area, Jinda Cheng,  
Xiner Village, Shajing Town, Boan District,  
Shenzhen City, Guangdong Province, China 518215  
Phone: +86.755.2726.7888