

# PX-2 SERIES

Long Range & Wide Area Photoelectric Sensor **Amplifier Built-in**



Compact size sensor realizes wide sensing area & long sensing range



## Ideal sensing area with very little null zone

The advanced optical system of the **PX-2** series reduces the null zones in front of an automatic guided vehicle (AGV).

The null zones at the sides are further minimized if auxiliary sensors which can be easily mounted with connectors are used.

(For **PX-24**, **PX-24ES**, **PX-23ES** and **PX-26**)

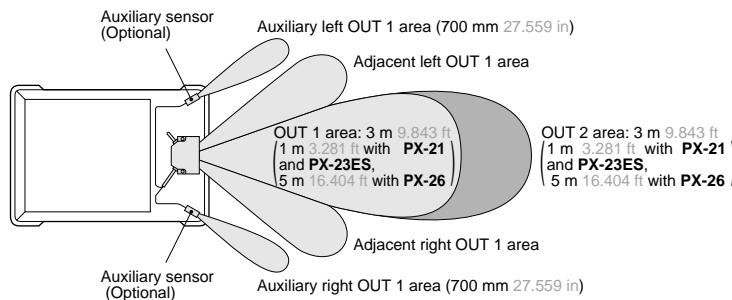

## Sensing areas selectable as per route condition

Sensing areas can be selected with switches to suit the route conditions of an AGV.

Further, in case of **PX-24ES** and **PX-23ES**, the sensing areas can also be selected with external signals.

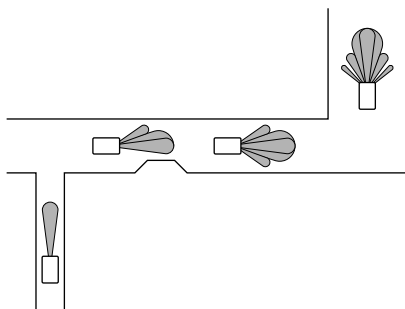

## Compact size for space-saving

Its size is half of a conventional model, and the attached cable orientation is freely adjustable. Hence, it can also fit in a small AGV.

Moreover, sensitivity adjustment can be done on the front face.

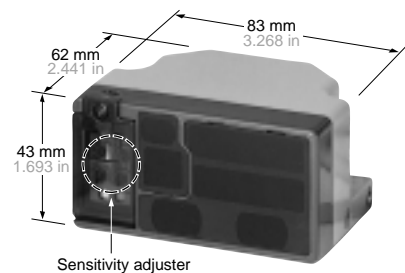

## Long sensing range 5 m 16.404 ft type

**PX-26** has a long sensing range of 5 m 16.404 ft. Even on a high-speed AGV, it can detect an object quite early so that slowing down and stopping are smooth.

## ORDER GUIDE

Type	Appearance	Sensing range	Model No.
Standard type		3 m 9.843 ft	<b>PX-22</b>
		1 m 3.281 ft	<b>PX-21</b>
Auxiliary sensor connectable type		3 m 9.843 ft	<b>PX-24</b>
		3 m 9.843 ft	<b>PX-24ES</b>
		1 m 3.281 ft	<b>PX-23ES</b>
		5 m 16.404 ft	<b>PX-26</b>
Auxiliary sensor		700 mm 27.559 in	<b>PX-SB1</b>

### Accessories

#### • MS-PX-2 (Main sensor mounting bracket)

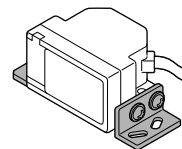

Two bracket set  
Four M4 (length 8 mm  
0.315 in) screws with  
washers are attached.

#### • MS-NX5-1 (Auxiliary sensor mounting bracket)

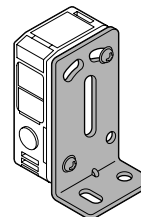

Two M4 (length 25 mm  
0.984 in) screws with  
washers and two M4 nuts  
are attached.

## OPTIONS

Designation	Model No.	Description
Auxiliary sensor mounting bracket	<b>MS-NX5-2</b>	Foot biangled mounting bracket (Sensor protection bracket)
	<b>MS-NX5-3</b>	Back angled mounting bracket

### Auxiliary sensor mounting bracket

#### • MS-NX5-2

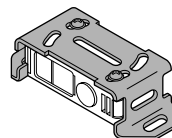

Two M4 (length 25 mm  
0.984 in) screws with  
washers and two M4 nuts  
are attached.

#### • MS-NX5-3

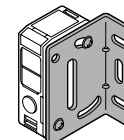

Two M4 (length 25 mm  
0.984 in) screws with  
washers and two M4 nuts  
are attached.

## Sleep function

The sensor can be put into the sleep (stand-by) condition when it is not used and can be restored to operating condition by an external signal. Consequently battery is conserved as the power consumption is reduced to 1/7.

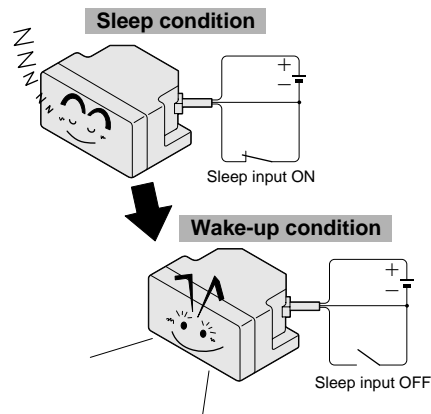

## Automatic interference prevention function

One **PX-2** sensor can simultaneously receive beams from 25 Nos. of other **PX-2** sensors without resulting in any interference. Even if AGVs are facing each other, the **PX-2** sensor on one AGV reliably detects the other AGVs. Hence, it can be safely used even at a place where several AGVs are moving.

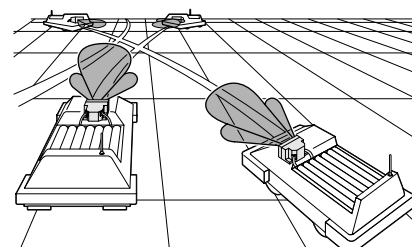

26 Nos. of **PX-2**'s can work at one site.

## External sensitivity adjustment

The sensitivity of the sensor can be adjusted, within the range set by the manual adjuster, by an external input. (For **PX-24**, **PX-24ES**, **PX-23ES** and **PX-26**)

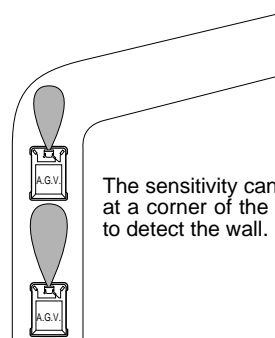

The sensitivity can be decreased at a corner of the path so as not to detect the wall.

## PX-2

## SPECIFICATIONS

## Main sensors

Type	Standard model		Auxiliary sensor connectable model				
	Short sensing range		With external control function		Long sensing range		
Item	Model No.	PX-22	PX-21	PX-24	PX-24ES	PX-23ES	PX-26
Sensing range (OUT 1 and OUT 2 areas) (Note 1)		3 m 9.843 ft	1 m 3.281 ft	3 m 9.843 ft		1 m 3.281 ft	5 m 16.404 ft
Hysteresis		15 % or less of operation distance					
Supply voltage		10 to 31 V DC including ripple					
Power consumption (Note 2)		Under operation: 1.5 W or less, Under sleep condition: 0.3 W or less (without auxiliary sensor)					
OUT 1 (OR circuit among the effective center, left, right, adjacent left / right OUT 1 areas and the effective auxiliary left / right areas)		NPN open-collector transistor					
OUT 2 (OR circuit among the effective center, left and right OUT 2 areas)		<ul style="list-style-type: none"> <li>• Maximum sink current: 100 mA</li> <li>• Applied voltage: 40 V DC or less (between OUT 1 / OUT 2 and 0 V)</li> <li>• Residual voltage: 1.5 V or less (at 100 mA sink current)</li> </ul>					
Utilization category		DC-12 or DC-13					
Output operation		Selectable either Light-ON or Dark-ON with a switch (Output operation of OUT 1 and OUT 2 is the same.)					
Short-circuit protection		Incorporated					
Extraneous light monitor output		_____		NPN open-collector transistor			
Output operation		_____		<ul style="list-style-type: none"> <li>• Maximum sink current: 100 mA</li> <li>• Applied voltage: 40 V DC or less (between extraneous light monitor output and 0 V)</li> <li>• Residual voltage: 1.5 V or less (at 100 mA sink current)</li> </ul>			
Short-circuit protection		_____		_____			
Response time		80 ms or less					
Operation indicators	OUT 1 area	Red LED (lights up when the beam is received in the effective OUT 1 areas)					
	OUT 2 area	Yellow LED (lights up when the beam is received in the effective OUT 2 areas)					
Sensitivity adjuster		Continuously variable adjusters (OUT 1, adjacent right OUT 1, adjacent left OUT 1 and OUT 2 areas are adjusted independently.)					
External sensitivity adjustment function		_____		Sensitivity adjustment is possible with an analog input.			
Sensing area		Four sensing areas are selectable with dip switches.			Four sensing areas are selectable with dip switches, and eight sensing areas are selectable with external inputs.		Fixed
Sleep function		Operating / sleep selectable with external input					
Automatic interference prevention function		Optical interference from up to 25 units is prevented.					
Environmental resistance	Pollution degree	3 (Industrial environment)					
	Protection	IP65 (IEC)					
	Ambient temperature	- 10 to + 55 °C + 14 to + 131 °F (No dew condensation or icing allowed), Storage: - 20 to + 70 °C - 4 to + 158 °F					
	Ambient humidity	35 to 85 % RH, Storage: 35 to 85 % RH					
	Ambient illuminance	Sunlight: 9,000 lx at the light-receiving face, Incandescent light: 3,000 lx at the light-receiving face					
	EMC	EN 50081-2, EN 50082-2, EN 60947-5-2					
	Voltage withstandability	1,000 V AC for one min. between all supply terminals connected together and enclosure					
	Insulation resistance	20 MΩ, or more, with 500 V DC megger between all supply terminals connected together and enclosure					
Vibration resistance		10 to 500 Hz frequency, 3 mm 0.118 in amplitude (20 G max.) in X, Y and Z directions for two hours each					
Shock resistance		500 m/s <sup>2</sup> acceleration (50 G approx.) in X, Y and Z directions for three times each					
Emitting element		Infrared LED (modulated)					
Material		Enclosure: ABS, Lens: Acrylic, Cover: Polycarbonate					
Cable		0.3 mm <sup>2</sup> 5-core cabtyre cable, 0.5 m 1.640 ft long (for input and output)		For input and output: 0.18 mm <sup>2</sup> 9-core (PX-24ES and PX-23ES: 12-core) cabtyre cable, 0.5 m 1.640 ft long For auxiliary sensor connection: 0.18 mm <sup>2</sup> 10-core connector attached cabtyre cable, 0.5 m 1.640 ft long			
Cable extension		Extension up to total 100 m 328.084 ft (10 m 32.808 ft for auxiliary sensor connection) is possible with 0.3 mm <sup>2</sup> , or more, cable.					
Weight		170 g approx.	210 g approx.	220 g approx.	210 g approx.		
Accessories		MS-PX-2 (Main sensor mounting bracket): 1 set, Adjusting screwdriver: 1 pc., Matrix chart for sensing areas and external inputs: 1 sheet (PX-24ES and PX-23ES only)					

Notes: 1) The sensing range is specified for white non-glossy paper (300 × 300 mm 11.811 × 11.811 in).

2) Obtain the current consumption by the following calculation.

Current consumption = Power consumption ÷ Supply voltage

(e.g.) When the supply voltage is 12 V, the current consumption (operating condition) is: 1.5 W ÷ 12 V = 0.125 A = 125 mA

## SPECIFICATIONS

### Auxiliary sensor (Note 1)

Item	Model No.	PX-SB1
Applicable main sensor		PX-24, PX-24ES, PX-23ES or PX-26
Connectable units		Up to two PX-SB1's can be connected to one main sensor.
Sensing range (Note 2)		700 mm 27.559 in
Supply voltage		Supplied from the main sensor
Current consumption		Current consumption of the main sensor increases by 30 mA approx. per auxiliary sensor.
Output		OR circuit with the main sensor's OUT 1
Operation indicator		Red LED (lights up when the beam is received)
Sensitivity adjuster		Continuously variable adjuster
Emitting element		Infrared LED (modulated)
Material		Polycarbonate
Cable		0.3 mm <sup>2</sup> 5-core cabtyre cable, 2 m 6.562 ft long
Cable extension		Extension up to total 10 m 32.808 ft is possible with 0.3 mm <sup>2</sup> , or more, cable.
Weight		130 g approx.
Accessories		MS-NX5-1 (Auxiliary sensor mounting bracket): 1 set, Adjusting screwdriver: 1 pc.

Specifications other than the above are identical with the main sensor.

Notes: 1) The auxiliary sensor cannot be used as a stand-alone unit.

2) The sensing range is specified for white non-glossy paper (300 × 300 mm 11.811 × 11.811 in) as the object.

## I/O CIRCUIT AND WIRING DIAGRAMS

### PX-24ES PX-23ES

#### I/O circuit diagram

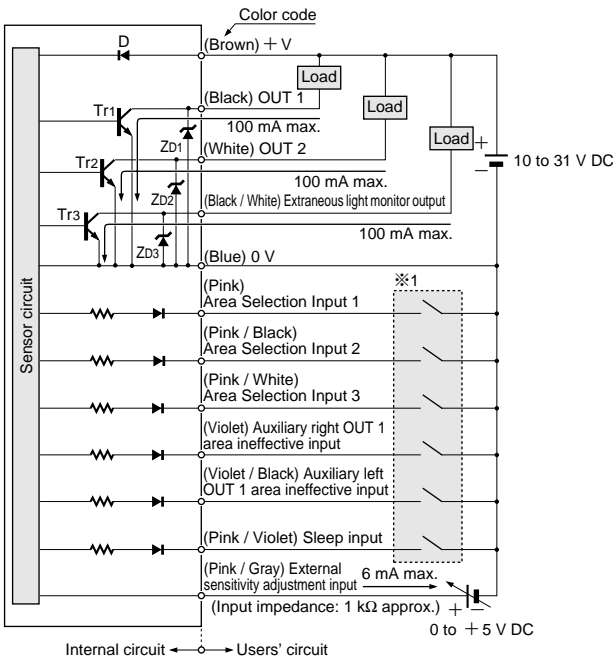

Symbols ... D: Reverse supply polarity protection diode  
Zd1, Zd2, Zd3: Surge absorption zener diode  
Tr1, Tr2, Tr3 : NPN output transistor

#### Wiring diagram

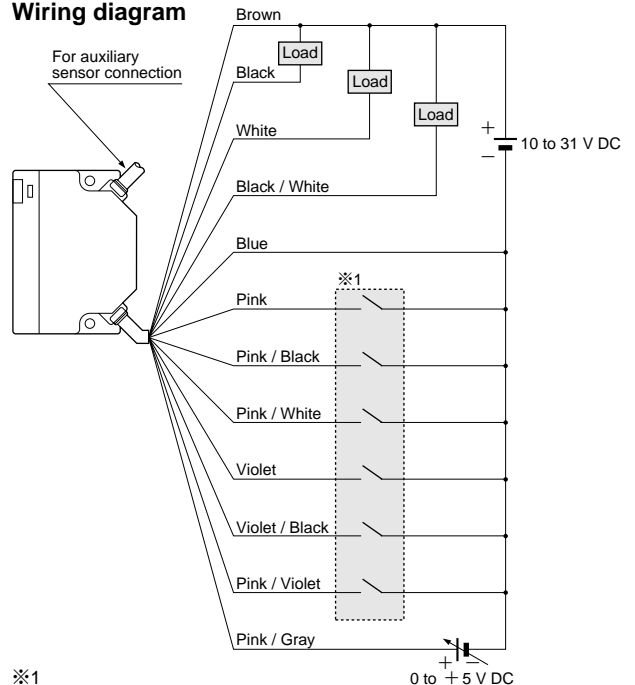

※1

Non-voltage contact or NPN open-collector transistor

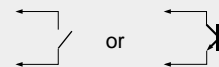

- Area selection input  
Low (0 to 1 V): Depends on the logic combination (refer to p.322)  
High (4.5 to 31 V, or open): Depends on the logic combination (refer to p.322)
- Auxiliary area ineffective input  
Low (0 to 1 V): Area ineffective  
High (4.5 to 31 V, or open): Area effective
- Sleep input  
Low (0 to 1 V): Sleep condition  
High [(supply voltage - 1 V) to 31 V, or open]: Operating condition

# PX-2

## I/O CIRCUIT AND WIRING DIAGRAMS

PX-22  
PX-21

### I/O circuit diagram

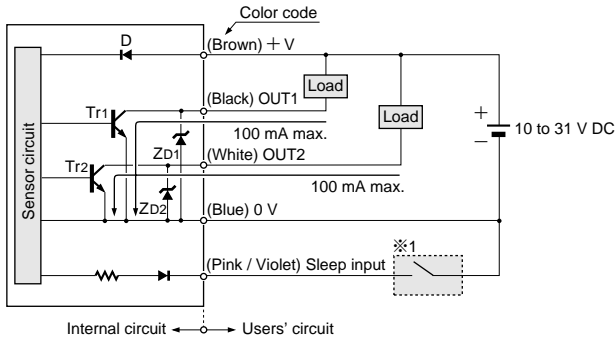

Symbols ... D: Reverse supply polarity protection diode  
ZD1, ZD2: Surge absorption zener diode  
Tr1, Tr2 : NPN output transistor

### Wiring diagram

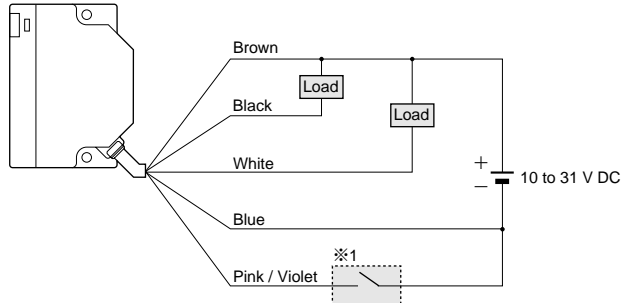

※1  
Non-voltage contact or NPN open-collector transistor

• Low (0 to 1 V): Sleep condition  
• High [(supply voltage - 1 V) to 31 V, or open]: Operating condition

PX-24  
PX-26

### I/O circuit diagram

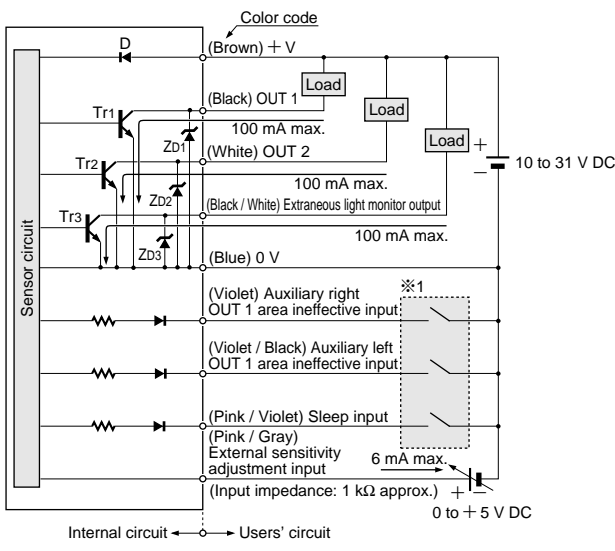

Symbols ... D: Reverse supply polarity protection diode  
ZD1, ZD2, ZD3: Surge absorption zener diode  
Tr1, Tr2, Tr3 : NPN output transistor

### Wiring diagram

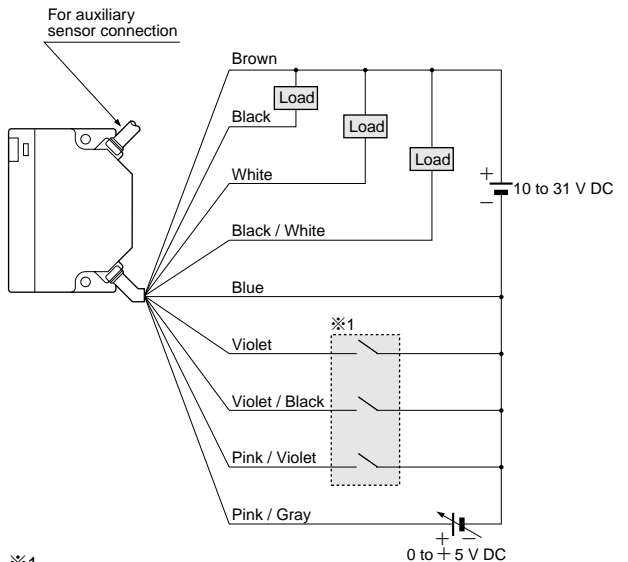

※1  
Non-voltage contact or NPN open-collector transistor

• Auxiliary area ineffective input  
Low (0 to 1 V): Area ineffective  
High (4.5 to 31 V, or open): Area effective  
• Sleep input  
Low (0 to 1 V): Sleep condition  
High [(supply voltage - 1 V) to 31 V, or open]: Operating condition

## SENSING CHARACTERISTICS (TYPICAL)

### How to read sensing characteristics

#### • Sensing field

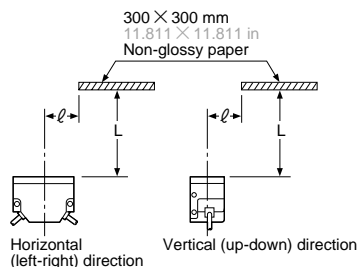

Note: The sensitivity has been adjusted so that the maximum sensing range for white non-glossy paper (300 X 300 mm 11.811 X 11.811 in) is 3 m 9.843 ft (1 m 3.281 ft for PX-21 and PX-23ES, 5 m 16.404 ft for PX-26) with the L, C and R areas effective.

#### Sensing area

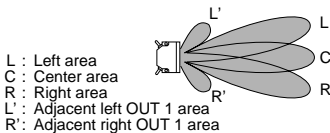

#### Sensing object

Type of non-glossy paper
White non-glossy paper (lightness: 9)
Gray non-glossy paper (lightness: 5)
Black non-glossy paper (lightness: 2)

#### • Correlation between external sensitivity adjustment input voltage and sensing range

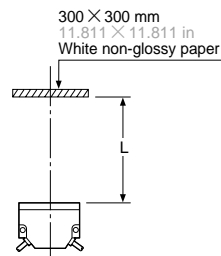

It shows the variation in the sensing range when the external input voltage is changed from 0 to +5 V with the sensitivity adjuster set at the maximum sensing range.

### All models

#### Correlation between setting distance and excess gain

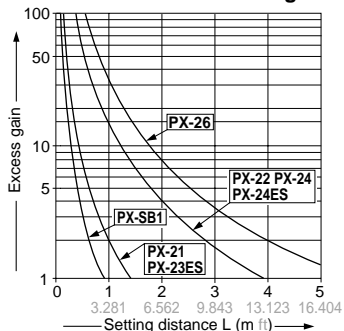

### PX-22 PX-24 PX-24ES

#### Sensing fields

##### • All areas effective (Horizontal)

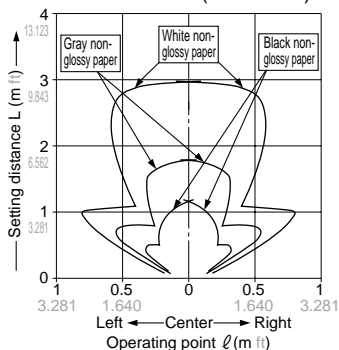

##### • C area effective (Horizontal)

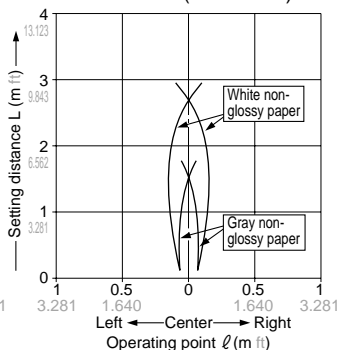

##### • All areas effective (Vertical)

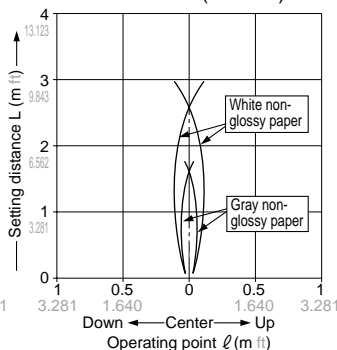

#### Correlation between external sensitivity adjustment input voltage and sensing range (Excluding PX-22)

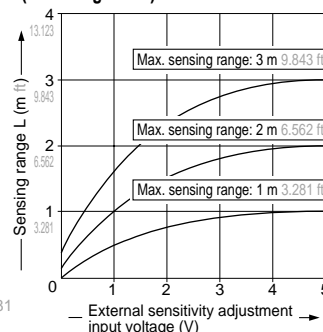

### PX-21 PX-23ES

#### Sensing fields

##### • All areas effective (Horizontal)

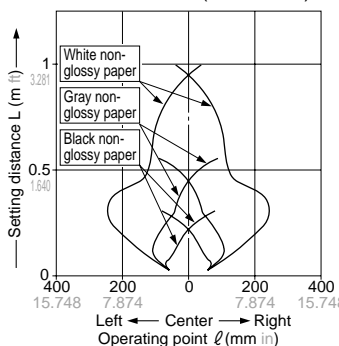

##### • C area effective (Horizontal)

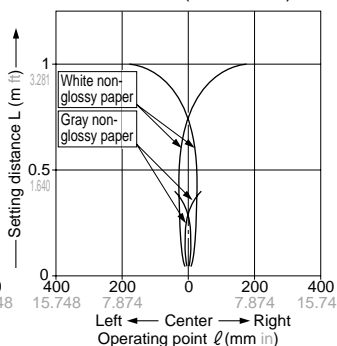

##### • All areas effective (Vertical)

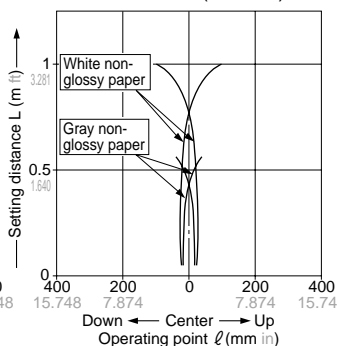

#### Correlation between external sensitivity adjustment input voltage and sensing range (PX-23ES only)

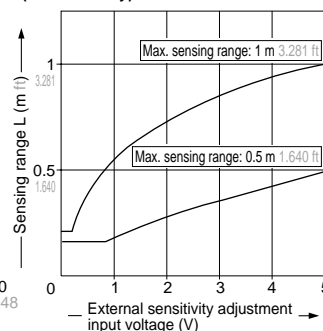

## SENSING CHARACTERISTICS (TYPICAL)

### PX-26

#### Sensing fields

- Horizontal (Area selection not possible)
- Vertical (Area selection not possible)

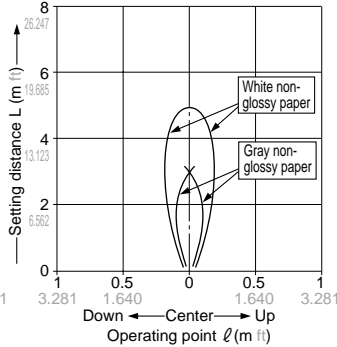
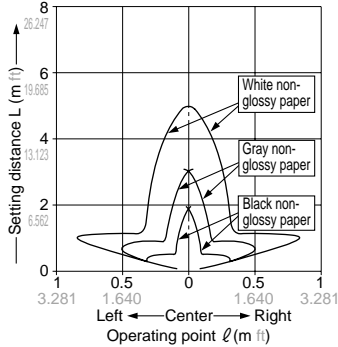

#### Correlation between external sensitivity adjustment input voltage and sensing range

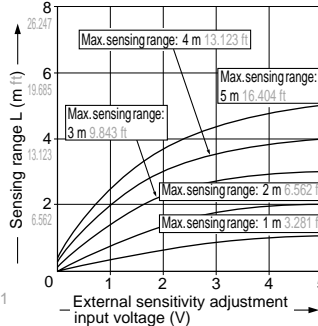

### PX-SB1

#### Sensing field

- Horizontal and vertical directions

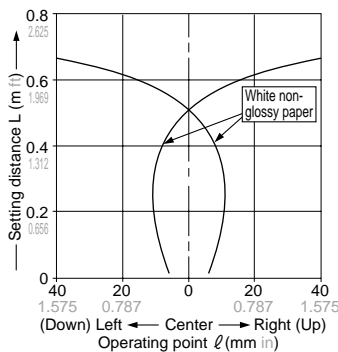

## PRECAUTIONS FOR PROPER USE

Refer to p.1135~ for general precautions.

### All models



This product is not a safety sensor. Its use is not intended or designed to protect life and prevent body injury or property damage from dangerous parts of machinery. It is a normal object detection sensor.

#### Hazard Indications

In this catalog, **WARNING** and **CAUTION** are indicated depending upon the level of danger. Please observe them strictly for the safe use of this sensor.

#### **WARNING**

'WARNING' indicates a potentially hazardous situation that, if not avoided, could result in death or serious injury.

#### **CAUTION**

'CAUTION' indicates a hazardous situation that, if not avoided, may result in minor or moderate injury. Further, they also indicate the condition of risk of physical damage to machinery.

#### **WARNING**

##### • Installation of a touch bumper

You are requested to always install a touch bumper when this product is used on an automatic guided vehicle (AGV).

#### **CAUTION**

##### • Use outside Japan

This sensor conforms to the EMC Directive. However, it is not certified by a competent body in accordance with other country safety standards. Since each country has its regulations, please follow the local and national regulations of the country where this sensor is used.

#### **CAUTION**

##### • Fail-safe measures

This sensor is meant for proximity detection and does not possess control functions for safety maintenance. If fail-safe measures are required, consider their incorporation in the total system. Further, do not connect the sensor output directly to a stopping mechanism (brake).

#### **CAUTION**

##### • Periodical maintenance check

The person in charge must periodically confirm the performance of the product and maintain a record of such checks. In addition, whenever the operating environment of the product is changed due to system modification, etc., performance check must be done.

## PRECAUTIONS FOR PROPER USE

Refer to p.1135~ for general precautions.

### All models

#### Mounting

- The tightening torque for the main sensor should be 1.2 N·m or less.

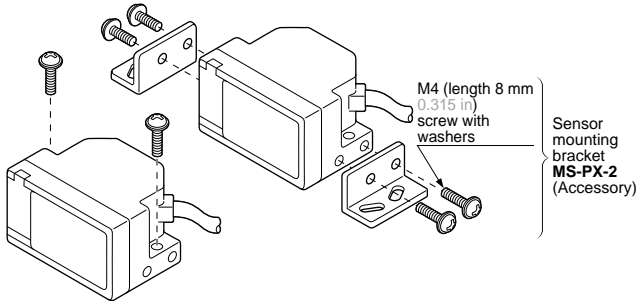

- The tightening torque for **PX-SB1** (auxiliary sensor) should be 0.8 N·m or less.

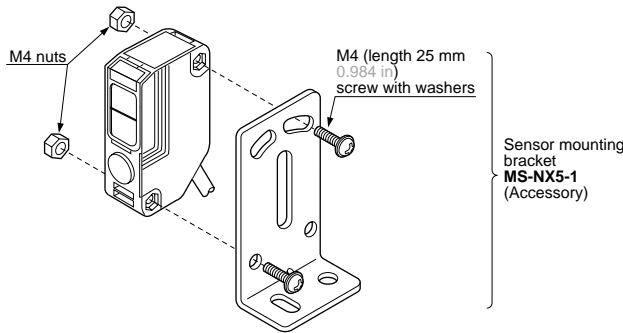

- Mount the sensor, horizontally, at least 300 mm 11.811 in above the floor, to avoid reflection from the floor.

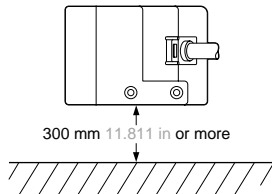

#### Automatic interference prevention function

- In case several sensors are used at the same place, take care that the number of sensors from which beams may be simultaneously incident is 25 or less.

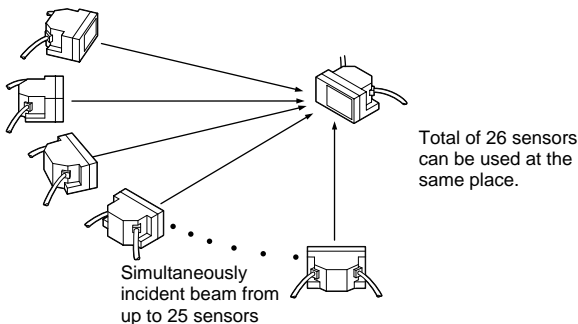

#### Sleep (stand-by) function

- When the sleep input is made Low, the sensor goes into the sleep state and the operation can be stopped.

- Notes:
- Response time of the sleep input is 50 ms.
  - Reactivation from the sleep state to the operation state takes 0.7 sec. approx. Operation during this transient state should be avoided.
  - When the sleep function is not used, keep the sleep input line open or insulated and prevent contact with other wires.

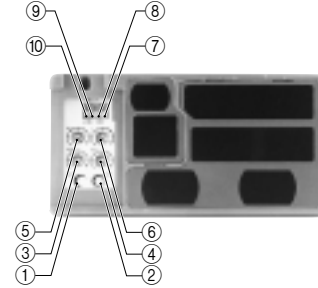

#### Functional description

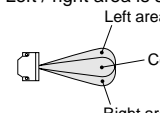
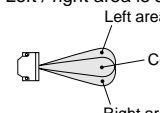
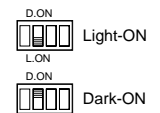
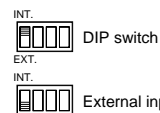

Description		Function
①	Operation indicator OUT 2 area (Yellow LED)	Lights up when light is received in OUT 2 area.
②	Operation indicator OUT 1 area (Red LED)	Lights up when light is received in OUT 1 area.
③	Sensitivity adjuster	OUT 2 area
④		OUT 1 area
⑤		Adjacent right OUT 1 area
⑥		Adjacent left OUT 1 area
⑦	Sensing area selection switch (Note 1)	Left / right area is selected. (OUT 1 and OUT 2)
⑧	Left area	 Left area Center area Right area
	Right area	 Left area Center area Right area
⑨	Output operation mode switch	Output operation mode of OUT 1 and OUT 2 is selected.  D.ON Light-ON L.ON D.ON Dark-ON L.ON
⑩	External control switch (Note 2)	This switch designates whether the sensing area selection is made by the DIP switches or the external inputs.  INT. DIP switch EXT. INT. External inputs EXT.

- Notes: 1) **PX-26** does not incorporate it.  
 2) **PX-24ES** and **PX-23ES** incorporate it.

#### Sensitivity adjustment

Step	Sensitivity adjuster	Operation
①		Make sure that the output operation mode selection switch is set to L-ON (ON when receiving light), and then turn the sensitivity adjuster fully counterclockwise.
②		Place an object to be detected at the required sensing position, and turn the sensitivity adjuster gradually clockwise and mark the point (A) where the indicator (Note 1) turns on.
③		Remove the object and turn the sensitivity adjuster further clockwise. Find out the point (B) where the indicator turns on again. Make sure that the difference between point (A) and (B) is 1 div., or more, on the scale. Then, set the sensitivity adjuster at point (A).
④	—	Carry out steps ①, ② and ③ for each of the areas OUT 2, OUT 1, adjacent left / right OUT 1 and auxiliary sensors (if they are connected).
⑤	—	After all the adjustments are made, the operator must confirm that the sensing area is set correctly by observing the detection of the object as it approaches from different directions.

- Notes:
- When adjusting the sensitivity of OUT 1 area, adjacent right OUT 1 area and adjacent left OUT 1 area, this is the OUT 1 area operation indicator (red). When adjusting the sensitivity of OUT 2 area, this is the OUT 2 area operation indicator (yellow).
  - Set areas other than the area you are adjusting as ineffective.
  - Use the accessory screwdriver to slowly turn the sensitivity adjuster. Turning with excessive force will damage the adjuster.



## PRECAUTIONS FOR PROPER USE

Refer to p.1135~ for general precautions.









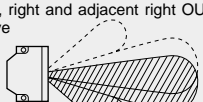
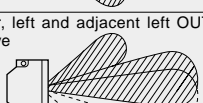
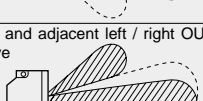

### All models

#### Others

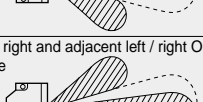
- Do not use during the initial transient time (0.7 sec.) after the power supply is switched on.
- Take care that an initial rush current (1.5 A approx. at 10 V DC and 5 A approx. at 31 V DC) will flow when the power supply is switched on.

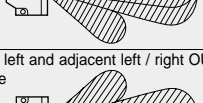
### PX-22 PX-21 PX-24 PX-24ES PX-23ES

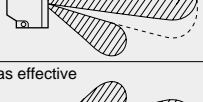
#### Sensing area selection

Setting method	Internal setting 	Area selection inputs (Note) <small>(PX-24ES and PX-23ES only)</small>		
		Input 1	Input 2	Input 3
<b>Sensing area</b> All areas ineffective 	—	L	L	L
Center area effective 	—	H	L	L
Center, right and adjacent right OUT 1 areas effective 	—	L	H	L
Center, left and adjacent left OUT 1 areas effective 	—	H	H	L
Center and adjacent left / right OUT 1 areas effective 		L	L	H
Center, right and adjacent left / right OUT 1 areas effective 		H	L	H
Center, left and adjacent left / right OUT 1 areas effective 		L	H	H
All areas effective 		H	H	H

L: Low (0 to 1 V), H: High (4.5 to 31 V, or open)  
 Note: The response time of the area selection inputs is 80 ms.

### PX-24 PX-24ES PX-23ES PX-26

#### External sensitivity adjustment function

- The sensitivity can be adjusted, within the range set by the manual sensitivity adjuster, by an analog voltage (0 to +5 V) applied to the external sensitivity adjustment input. The sensitivity varies with the magnitude of the applied voltage.

Notes: 1) The sensitivity of the auxiliary sensor is not changed.  
 2) Sensitivity adjustment beyond the range set by the manual sensitivity adjuster is not possible.

Input voltage	0 V ↔ +5 V or open
Sensitivity	Minimum ↔ Maximum (Maximum sensitivity set by the manual sensitivity adjuster)

Note: This wire should be insulated if it is not used.

#### Extraneous light monitor function

(Incorporated in **PX-24, PX-24ES, PX-23ES** and **PX-26** only)

- If the sensor receives modulated light other than its own (including auxiliary sensor's) light, the extraneous light monitor output turns ON. The operation of the extraneous light monitor output has absolutely no affect on sensing. It is useful for recognizing presence of other sensors near this sensor in case of intersecting AGV paths, etc.

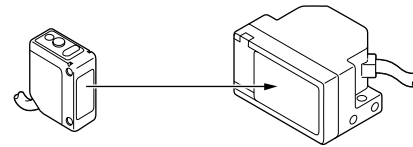

Note: The extraneous light monitor output is not incorporated with a short-circuit protection circuit. Do not connect it directly to a power supply or a capacitive load.

## PRECAUTIONS FOR PROPER USE

Refer to [p.1135](#) for general precautions.

### PX-SB1

- This sensor must always be used with the applicable main sensor. This sensor does not work as a stand-alone unit. (It cannot be used with **PX-22** or **PX-21**.)

#### Selection of the auxiliary sensing areas

- The auxiliary sensing areas are controlled by the auxiliary area ineffective inputs of the main sensor.

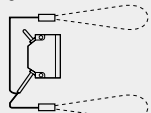
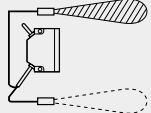
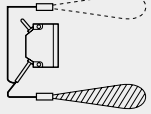
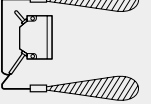
Area ineffective input Sensing area	Auxiliary left OUT 1 area	Auxiliary right OUT 1 area
Auxiliary left / right OUT 1 areas ineffective 	L	L
Auxiliary left OUT 1 area effective 	H	L
Auxiliary right OUT 1 area effective 	L	H
Auxiliary left / right OUT 1 areas effective 	H	H

L: Low (0 to 1 V), H: High (4.5 to 31 V, or open)

Note: The ineffective auxiliary area inputs are not related to the external control switch on the main sensor.

Amplifier Built-in	CY
	PX-2
Sensor Mounting Stand	RT-610
	MS-AJ
Micro	PM
	PM2
Multi-voltage	NX5
	VF
EQ-500	



**DIMENSIONS (Unit: mm in)** The CAD data in the dimensions can be downloaded from the SUNX website: <http://www.sunx.co.jp/>

## PX-SB1 Auxiliary sensor

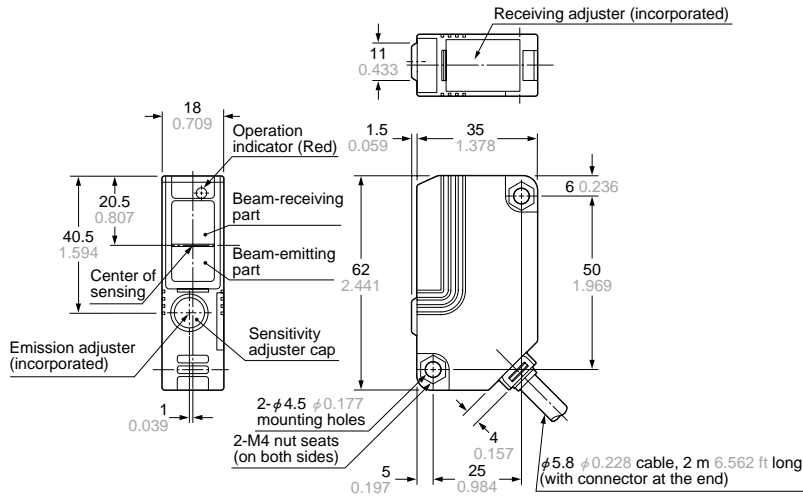

## MS-PX-2 Main sensor mounting bracket (Accessory for PX-2□)

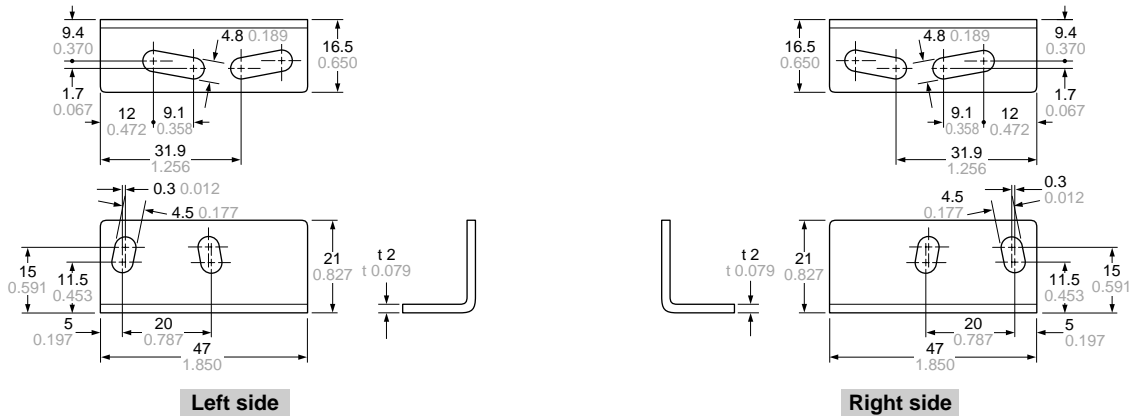

Material: Cold rolled carbon steel (SPCC)  
(Uni-chrome plated)  
Four M4 (length 8 mm 0.315 in) screws with washers are attached.

## Assembly dimensions Mounting drawing with PX-24

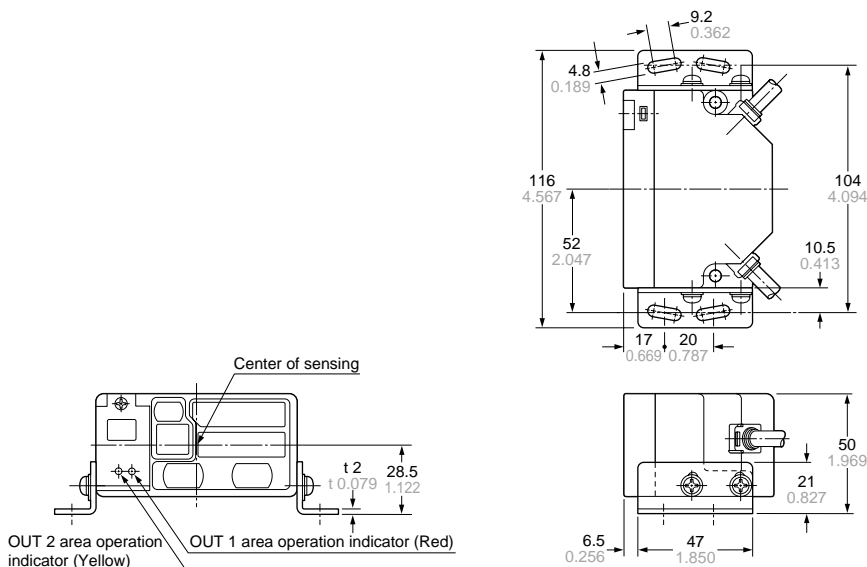

**DIMENSIONS (Unit: mm in)** The CAD data in the dimensions can be downloaded from the SUNX website: <http://www.sunx.co.jp/>

## MS-NX5-1 Auxiliary sensor mounting bracket (Accessory for PX-SB1)

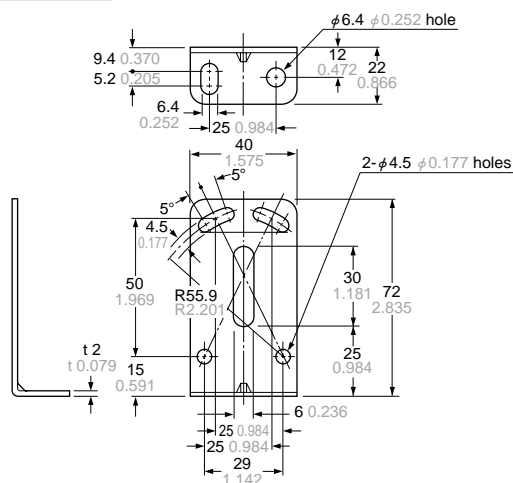

### Assembly dimensions

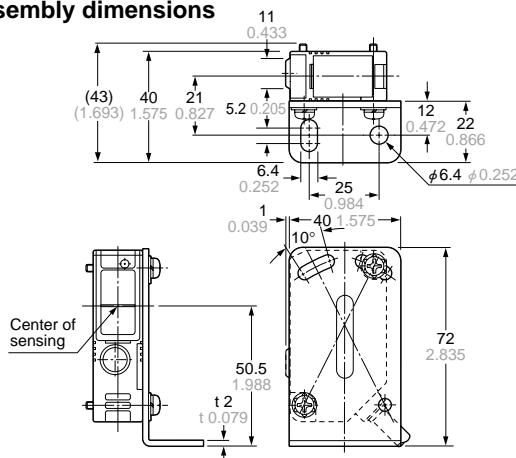

Material: Cold rolled carbon steel (SPCC)(Uni-chrome plated)  
Two M4 (length 25 mm 0.984 in) screws with washers and two M4 nuts are attached.

## MS-NX5-2 Auxiliary sensor mounting bracket (Optional)

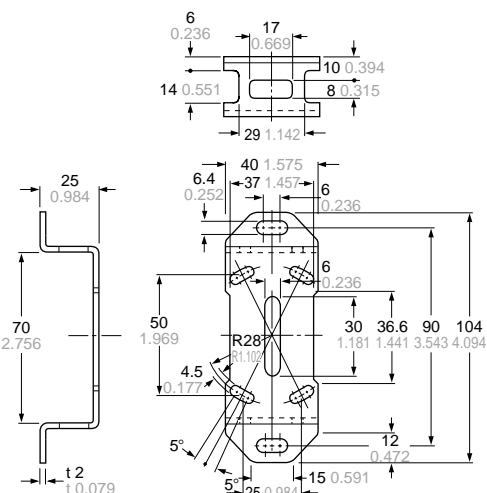

### Assembly dimensions

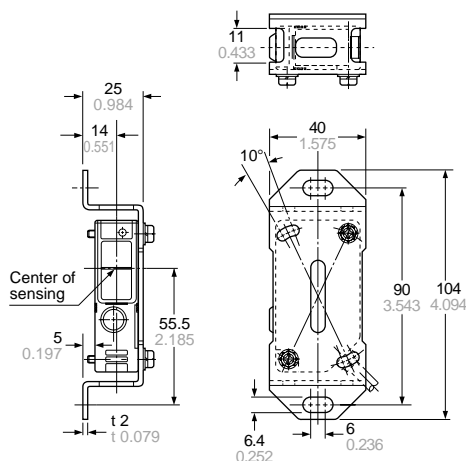

Material: Cold rolled carbon steel (SPCC)(Uni-chrome plated)  
Two M4 (length 25 mm 0.984 in) screws with washers and two M4 nuts are attached.

## MS-NX5-3 Auxiliary sensor mounting bracket (Optional)

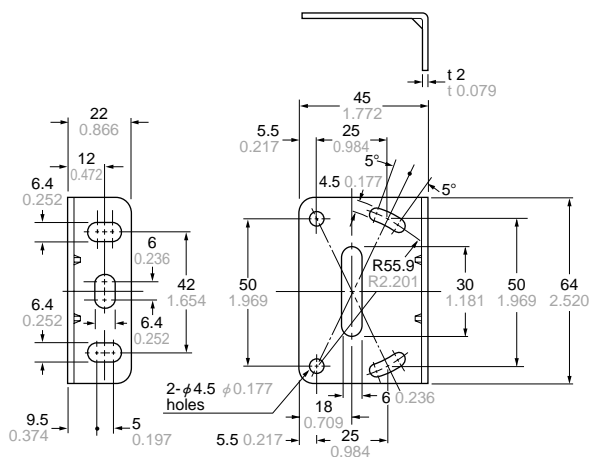

### Assembly dimensions

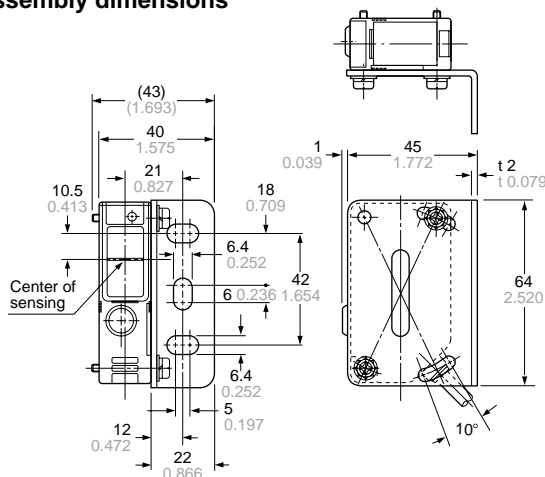

Material: Cold rolled carbon steel (SPCC)(Uni-chrome plated)  
Two M4 (length 25 mm 0.984 in) screws with washers and two M4 nuts are attached.