

Description

The PSS/PSK Series of positive switching regulators is designed as power supplies for electronic systems, where no input-to-output isolation is required. Their major advantages include a high level of efficiency, high reliability, low output ripple, and excellent dynamic response. Models with input voltages up to 144 V are specially designed for secondary switched and battery-driven mobile applications. The converters are suitable for railway applications according to EN 50155 and EN 50121.

Two type of housings are available allowing operation up to 71 °C. They are designed for insertion into a 19" DIN-rack or for chassis mounting. Replacing the heat sink by an optional cooling plate, allows chassis or wall mounting on top of a metal surface, acting as heat sink.

Various options are available to adapt the converter to different applications. Connector type: H15 or H15S4, depending on output current.

Features

- Input voltage up to 144 VDC
- Single output of 3.3 to 48 VDC
- No input-to-output isolation
- High efficiency up to 97%
- Extremely wide input voltage range
- Low input-to-output differential voltage
- Very good dynamic properties
- Input undervoltage lockout
- Active current sharing for parallel operation
- Output voltage adjustment, inhibit, and sense lines
- Continuously no-load and short-circuit proof
- All boards are coated with a protective lacquer



Table of Contents

Table of Contents	Page	Page	
Description	1	Immunity to Environmental Conditions	13
Model Selection	2	Mechanical Data	14
Functional Description	3	Safety and Installation Instructions	16
Electrical Input Data	4	Description of Options	17
Electrical Output Data	6	Accessories	19
Auxiliary Functions	10	EC Declaration of Conformity	20
Electromagnetic Compatibility (EMC)	12		

Model Selection

Table 1: All models

Output voltage $V_{o\ nom}$ [V]	Output current $I_{o\ nom}$ [A]	Operating input voltage range V_i [V]	Nom. input voltage $V_{i\ nom}$ [V]	Efficiency ²		Type designation	Connector type	Options
				η_{min} [%]	η_{typ} [%]			
3.3	25	8 – 40	20	81	82	PSK3E25-7	H15S4	-9, E, B, B1, G
5.1	12	8 – 80	40	78	79	PSS5A12-7	H15	-9, E, P, C, B, B1, G
5.1	14	8 – 40	20	83		PSS5A14-2	H15	B, B1
5.1	16	8 – 80	40	78	79	PSK5A16-7	H15	-9, E, P, C, B, B1, G
5.1	18	8 – 40	20	82		PSS5A18-2	H15	B, B1
5.1	20	8 – 80	40	78	79	PSK5A20-9	H15S4	-9, E, P, C, B, B1, G
5.1	25	8 – 40	20	82	82	PSK5A25-9	H15S4	-9, E, P, C, B, B1, G
12	9	18 – 144 ¹	60	90	91	PSS129-7	H15	-9, E, P, C, B, B1, G
12	12	15 – 80	40	90	91	PSS1212-7	H15	-9, E, P, C, B, B1, G
12	12	18 – 144 ¹	60	90	91	PSK1212-7	H15	-9, E, P, C, B, B1, G
12	14	15 – 40	30	90		PSS1214-2	H15	B, B1
12	16	15 – 80	40	89	90	PSK1216-7	H15	-9, E, P, C, B, B1, G
12	18	15 – 40	30	90		PSK1218-2	H15	B, B1
12	20	15 – 80	40	89	90	PSK1220-7	H15S4	-9, E, P, C, B, B1, G
15 ³	9	22 – 144 ¹	60	90	92	PSS129-7	H15	-9, E, C, B, B1, G
15 ³	12	19 – 80	40	90	92	PSS1212-7	H15	-9, E, C, B, B1, G
15 ³	12	22 – 144 ¹	60	90	92	PSK1212-7	H15	-9, E, C, B, B1, G
15 ³	14	19 – 40	30	90		PSS1214-2	H15	B, B1
15 ³	16	19 – 80	40	89	90	PSK1216-7	H15	-9, E, C, B, B1, G
15 ³	18	19 – 40	30	90		PSK1218-2	H15	B, B1
15 ³	20	19 – 80	40	89	90	PSK1220-7	H15S4	-9, E, C, B, B1, G
24	9	31 – 144 ¹	60	93	94	PSS249-7	H15	-9, E, P, C, B, B1, G
24	12	29 – 80	50	93	94	PSS2412-7	H15	-9, E, P, C, B, B1, G
24	12	31 – 144 ¹	60	93	94	PSK2412-9	H15	-9, E, P, C, B, B1, G
24	14	29 – 60	40	94		PSS2414-2	H15	B, B1
24	16	29 – 80	50	93	94	PSK2416-9	H15	-9, E, P, C, B, B1, G
24	18	29 – 60	40	90		PSK2418-2	H15	B, B1
24	20	29 – 80	50	93	94	PSK2420-9	H15S4	-9, E, P, C, B, B1, G
36	9	44 – 144 ¹	80	95	96	PSS369-9	H15	-9, E, P, C, B, B1, G
36	12	42 – 80	60	93	94	PSS249-9	H15	
36	12	44 – 144 ¹	80	95	96	PSK3612-9	H15	
36	16	42 – 80	60	94	95	PSK3616-9	H15	
36	20	42 – 80	60	94	95	PSK3620-9	H15S4	
48	9	58 – 144 ¹	80	96	97	PSS489-9	H15	
48	12	58 – 144 ¹	80	96	97	PSK4812-9	H15	

¹ Surges up to 156 V for 2 s; see *Electrical Input Data*

² Efficiency at $V_{i\ nom}$ and $I_{o\ nom}$.

³ Output voltage V_o set to 15 V by R input

⁴ Not available for PSK3E25

Note: Non-standard input/output configurations or special custom adaptations are available on request.

Part Number Description

Positive switching regulator in case S01, K01	PSS, PSK	PSK	12	12	-7	E	P	C	B	G
Nominal output voltage in volt	3.3 – 48									
Nominal output current in ampere	9 – 25									
Operational ambient temperature range T_A										
– 10 to 50 °C	-2									
– 25 to 71 °C	-7									
– 40 to 71 °C (optional)	-9									
Options: Inrush current limitation	E									
Potentiometer to adjust V_o ¹	P									
Thyristor crowbar	C									
Cooling plate large/small	B, B1									
RoHS-compliant for all 6 substances	G ²									

¹ Option P excludes R-features and vice versa.

² G is always placed at the end of the part number. Consult Power-One for availability!

Example: PSS 129-7EPCB = Positive switching regulator with output 12 V, 9 A, ambient temperature range of –25 to 71 °C, inrush current limitation, potentiometer, crowbar, and large cooling plate option B.

Product Marking

Type designation, applicable safety approvals and recognition marks, warnings, pin allocation, Power-One patents and company logo.

Identification of LED, test sockets, and optional potentiometer.

Input voltage range, nominal output voltage and current, protection degree, batch no., serial no., and data code including production site, version (modificationstatus), and date of production.

Functional Description

The switching regulators are using the buck converter topology. The input is not electrically isolated from the output. During the on period of the switching FET, current is transferred to the output, and energy is stored in the output choke. During the off period, this energy forces the current to continue flowing through the output chocke to the load and

back through the freewheeling diode. Regulation is accomplished by varying on/off duty cycle.

These regulators are ideal for applications, where an input to output isolation is not necessary or where it is already provided by an external front end, e.g., a transformer with rectifier. To optimize customer's needs, various options and accessories are available.

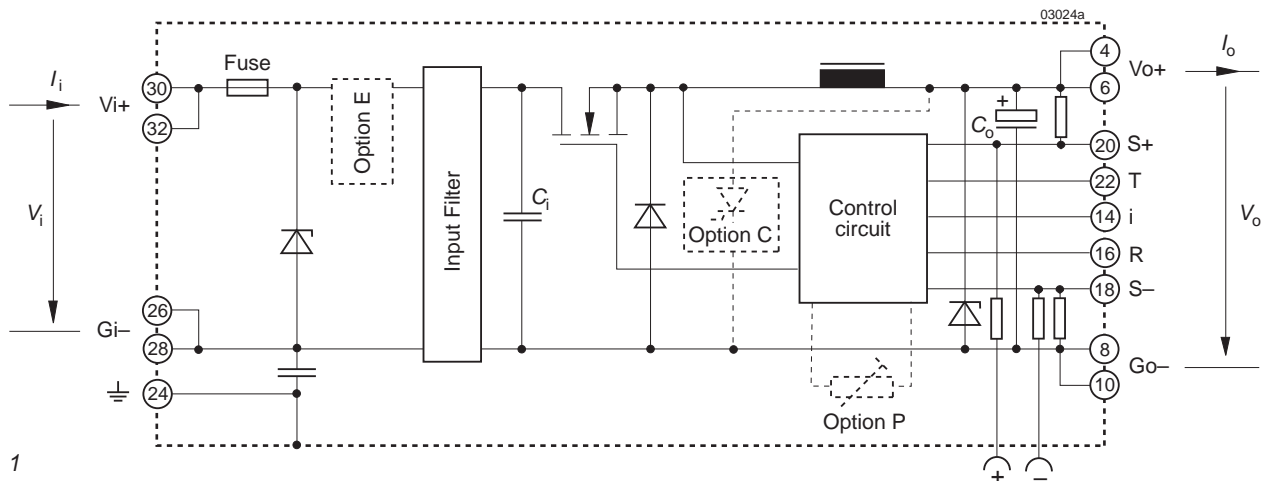

Fig. 1
Block diagram

Electrical Input Data

Table 2a: Input data. General Conditions: $T_A = 25\text{ }^\circ\text{C}$, unless T_C is specified

Input			PSS5A14 PSK5A18			PSS1214 PSK1218			PSS2414 PSK2418			Unit
Characteristics		Conditions	min	typ	max	min	typ	max	min	typ	max	
V_i	Operating input voltage	$I_o = 0 - I_{o\text{ nom}}$	8		40	15/19 ¹		40	29		60	VDC
$\Delta V_{i0\text{ min}}$	Min. diff. voltage $V_i - V_o$	$T_{C\text{ min}} - T_{C\text{ max}}$			2.9			3/4 ¹			5	
V_{i0}	Undervoltage lock-out			7.3			7.3			12		
I_{i0}	No load input current	$I_o = 0, V_{i\text{ min}} - V_{i\text{ max}}$			50			50			50	mA
$V_{i\text{ RFI}}$	Input RFI level, EN 55011/22 0.15 – 30 MHz	$V_{i\text{ nom}}, I_{o\text{ nom}}$			A			A			A	

¹ The second value is valid, if output is set to 15 V with the R-input.

Table 2b: Input data. General Conditions: $T_A = 25\text{ }^\circ\text{C}$, unless T_C is specified

Input			PSK3E25 PSK5A25			PSS5A12 PSK5A16 PSK5A20			PSS1212 PSK1216 PSK1220			Unit
Characteristics		Conditions	min	typ	max	min	typ	max	min	typ	max	
V_i	Operating input voltage ¹	$I_o = 0 - I_{o\text{ nom}}$	8		40	8		80	15		80	VDC
$\Delta V_{i0\text{ min}}$	Min. diff. voltage $V_i - V_o$	$T_{C\text{ min}} - T_{C\text{ max}}$			4.7/2.9 ¹			2.9			3	
V_{i0}	Undervoltage lock-out			6.5			6.5			7.3		
I_{i0}	No load input current	$I_o = 0, V_{i\text{ min}} - V_{i\text{ max}}$			50			50			50	mA
$I_{i\text{ nr p}}$	Peak value of inrush current	$V_{i\text{ nom}}$, with option E			20			40			40	A
$V_{i\text{ RFI}}$	Input RFI level, EN 55011/22 0.15 – 30 MHz	$V_{i\text{ nom}}, I_{o\text{ nom}}$			B			B			B	

¹ Values for PSK3E25/PSK5A20

Table 2c: Input data. General Conditions: $T_A = 25\text{ }^\circ\text{C}$, unless T_C is specified

Input			PSS1212 ¹ PSK1216 PSK1220			PSS2412 PSK2416 PSK2420			PSS3612 PSK3616 PSK3620			Unit
Characteristics		Conditions	min	typ	max	min	typ	max	min	typ	max	
V_i	Operating input voltage ¹	$I_o = 0 - I_{o\text{ nom}}$	19		80	29		80	42		80	VDC
$\Delta V_{i0\text{ min}}$	Min. diff. voltage $V_i - V_o$	$T_{C\text{ min}} - T_{C\text{ max}}$			4			5			6	
V_{i0}	Undervoltage lock-out			7.3			12			19		
I_{i0}	No load input current	$I_o = 0, V_{i\text{ min}} - V_{i\text{ max}}$			50			50			50	mA
$I_{i\text{ nr p}}$	Peak value of inrush current	$V_{i\text{ nom}}$, with option E			40			50			90	A
$V_{i\text{ RFI}}$	Input RFI level, EN 55011/22 0.15 – 30 MHz	$V_{i\text{ nom}}, I_{o\text{ nom}}$			B			B			B	

¹ Output set to 15 V with the R-input.

Table 2d: Input data. General Conditions: $T_A = 25\text{ }^\circ\text{C}$, unless T_C is specified

Input			PSS129 PSK1212			PSS129 ¹ PSK1212 ¹			PSS249 PSK2412			Unit
Characteristics		Conditions	min	typ	max	min	typ	max	min	typ	max	
V_i	Operating input voltage	$I_o = 0 - I_{o\text{ nom}}$ $T_C\text{ min} - T_C\text{ max}$	18		144 ²	22		144 ²	31		144 ²	VDC
$\Delta V_{io\text{ min}}$	Min. diff. voltage $V_i - V_o$				6			7			7	
V_{io}	Undervoltage lock-out				12			12			24	
I_{io}	No load input current	$I_o = 0, V_{i\text{ min}} - V_{i\text{ max}}$			50			50			50	mA
$I_{inr\text{ p}}$	Peak value of inrush current	$V_{i\text{ nom}}$, with option E			4.5			4.5			4.5	A
$V_{i\text{ RFI}}$	Input RFI level, EN 55011/22 0.15 – 30 MHz	$V_{i\text{ nom}}, I_{o\text{ nom}}$			B			B			B	

¹ Output set to 15 V with the R-input.

² Surges up to 156 V for 2 s are allowed.

Table 2e: Input data. General Conditions: $T_A = 25\text{ }^\circ\text{C}$, unless T_C is specified

Input			PSS369 PSK3612			PSS488 PSK4812			Unit
Characteristics		Conditions	min	typ	max	min	typ	max	
V_i	Operating input voltage	$I_o = 0 - I_{o\text{ nom}}$ $T_C\text{ min} - T_C\text{ max}$	18		144 ¹	22		144 ¹	VDC
$\Delta V_{io\text{ min}}$	Min. diff. voltage $V_i - V_o$				8			10	
V_{io}	Undervoltage lock-out				36			48	
I_{io}	No load input current	$I_o = 0, V_{i\text{ min}} - V_{i\text{ max}}$			50			50	mA
$I_{inr\text{ p}}$	Peak value of inrush current	$V_{i\text{ nom}}$, with option E			6			6	A
$V_{i\text{ RFI}}$	Input RFI level, EN 55011/22 0.15 – 30 MHz	$V_{i\text{ nom}}, I_{o\text{ nom}}$			B			B	

¹ Surges up to 156 V for 2 s are allowed.

Input Filter and Fuse

An input filter and a fuse are incorporated in all converters as standard. The filter reduces emitted electrical noise and prevents oscillations caused by the negative input impedance

Table 3: Input fuses

Model	Fuse type	Size	Supplier
PSK3E25, PSK5A20, PSK5A25 PSK1220, PSK2420, PSK3620	F 25 A	6.3 × 32 mm	Littlefuse
PSK5A16, PSK1216, PSK1218 PSK2416, PSK2418, PSK3620	F 20 A		
PSS5A12, PSS5A14, PSS1212, PSK1212, PSS1214 PSS2412, PSK2412, PSS2414 PSS3612, PSK3612, PSK3616 PSK4812	F 15 A		
PSS129, PSS249 PSS369, PSS489	F 10 A		

characteristic of a switched mode regulator. The input fuse protects against severe defects.

The maximum permissible additionally superimposed ripple v_i of the input voltage (rectifier mode) at a specified input frequency f_i has the following values:

$$V_{i\text{ max}} = 10 V_{pp} \text{ at } 100 \text{ Hz, or } V_{pp} = 1000 \text{ Hz}/f_i \cdot 1 \text{ V}$$

The input fuses are specified in the table 3.

Inrush Current

Depending on the input source and the input impedance, the inrush current into the converter may reach a very high peak value during the switch-on sequence. It also determine the rating of input devices such as switches, relays, fuses, etc. To protect these input devices by limiting the inrush current, we recommend the choice of the active inrush current limitation circuit, option E.

Electrical Output Data

General Conditions:

- $T_A = 25^\circ\text{C}$, unless T_C is specified
- R control (pin 16) not connected or programmed to $V_{O\text{ nom}}$ at $I_{O\text{ nom}}$
- Inhibit input (pin 14) connected to Go-
- Sense lines S+ and S- connected at female connector

Table 3a: Output data of PSS models

Output			PSS5A12			PSS1212			PSS1212 ¹			Unit
Characteristics		Conditions	min	typ	max	min	typ	max	min	typ	max	
V_o	Output voltage	$V_{i\text{ nom}}, I_{O\text{ nom}}$	5.07		5.13	11.93		12.07	14.91		15.09	V
I_o	Output current	$V_{i\text{ min}} - V_{i\text{ max}}$	0		12	0		12	0		12	A
I_{oL}	Output current limit	$T_{C\text{ min}} - T_{C\text{ max}}$	12		15	12		15	12		15	
v_o	Output voltage noise	Switching freq.	$V_{i\text{ nom}}, I_{O\text{ nom}}$			20			20			mV _{pp}
		Total incl. spikes	IEC/EN 61204 BW = 20 MHz			40			45			
						24			49			
ΔV_{oV}	Static line regulation	$V_{i\text{ min}} - V_{i\text{ max}}, I_{O\text{ nom}}$	15		35	40		70	50		80	mV
ΔV_{oI}	Static load regulation	$V_{i\text{ nom}}, I_o = 0 - I_{O\text{ nom}}$	10		25	30		50	35		55	
$v_{o d}$	Dynamic load regulation	Voltage deviat.	$V_{i\text{ nom}}$			70			140			μs
t_d		Recovery time	$I_{O\text{ nom}} \leftrightarrow 1/3 I_{O\text{ nom}}$ IEC/EN 61204			40			60			
α_{V_o}	Temperature coefficient $\Delta V_o/\Delta T_C$ ($T_{C\text{ min}}$ to $T_{C\text{ max}}$)	$V_{i\text{ min}} - V_{i\text{ max}}$ $I_o = 0 - I_{O\text{ nom}}$				±1			±3			mV/K
						±0.02			±0.02			

¹ Output set to 15 V with R-input.

Table 3b: Output data of PSS models. General conditions as per table 3a

Output			PSS2412			PSS2414			PSS3612			Unit
Characteristics		Conditions	min	typ	max	min	typ	max	min	typ	max	
V_o	Output voltage	$V_{i\text{ nom}}, I_{O\text{ nom}}$	23.86		24.14	23.2		24.7	35.78		36.22	V
I_o	Output current	$V_{i\text{ min}} - V_{i\text{ max}}$	0		12	0		14	0		12	A
I_{oL}	Output current limit	$T_{C\text{ min}} - T_{C\text{ max}}$	12		15	14		17.5	12		15	
v_o	Output voltage noise	Switching freq.	$V_{i\text{ nom}}, I_{O\text{ nom}}$			30			300			mV _{pp}
		Total incl. spikes	IEC/EN 61204 BW = 20 MHz			60			310			
						34			64			
ΔV_{oV}	Static line regulation	$V_{i\text{ min}} - V_{i\text{ max}}, I_{O\text{ nom}}$	80		170			480	120		250	mV
ΔV_{oI}	Static load regulation	$V_{i\text{ nom}}, I_o = 0 - I_{O\text{ nom}}$	50		120			240	60		200	
$v_{o d}$	Dynamic load regulation	Voltage deviat.	$V_{i\text{ nom}}$			180			700			μs
t_d		Recovery time	$I_{O\text{ nom}} \leftrightarrow 1/3 I_{O\text{ nom}}$ IEC/EN 61204			60			60			
α_{V_o}	Temperature coefficient $\Delta V_o/\Delta T_C$ ($T_{C\text{ min}}$ to $T_{C\text{ max}}$)	$V_{i\text{ min}} - V_{i\text{ max}}$ $I_o = 0 - I_{O\text{ nom}}$				±5			±5			mV/K
						±0.02			±0.02			

Table 3c: Output data of PSS models. General conditions as per table 3a

Output			PSS129			PSS129 ¹			PSS249			Unit	
Characteristics		Conditions	min	typ	max	min	typ	max	min	typ	max		
V_o	Output voltage	$V_{i\text{ nom}}, I_{o\text{ nom}}$	11.93		12.07	14.91		15.09	23.86		24.14	V	
I_o	Output current	$V_{i\text{ min}} - V_{i\text{ max}}$	0		9	0		9	0		9	A	
I_{oL}	Output current limit	$T_{C\text{ min}} - T_{C\text{ max}}$	9		11.25	19		11.25	9		11.25		
v_o	Output voltage noise	Switching freq.	$V_{i\text{ nom}}, I_{o\text{ nom}}$		25	50	$V_{i\text{ nom}}, I_{o\text{ nom}}$		20	45	$V_{i\text{ nom}}, I_{o\text{ nom}}$		mV _{pp}
		Total incl. spikes	IEC/EN 61204 BW = 20 MHz		29	54	IEC/EN 61204 BW = 20 MHz		34	64	IEC/EN 61204 BW = 20 MHz		
ΔV_{oV}	Static line regulation	$V_{i\text{ min}} - V_{i\text{ max}}, I_{o\text{ nom}}$	40		70	50		80	80		170	mV	
ΔV_{oI}	Static load regulation	$V_{i\text{ nom}}, I_o = 0 - I_{o\text{ nom}}$	30		50	40		60	50		120		
$v_{o d}$	Dynamic load regulation	Voltage deviat.	$V_{i\text{ nom}}$		140	$V_{i\text{ nom}}$		140	$V_{i\text{ nom}}$		180	μs	
t_d		Recovery time	$I_{o\text{ nom}} \leftrightarrow 1/3 I_{o\text{ nom}}$ IEC/EN 61204		60	$I_{o\text{ nom}} \leftrightarrow 1/3 I_{o\text{ nom}}$ IEC/EN 61204		60	$I_{o\text{ nom}} \leftrightarrow 1/3 I_{o\text{ nom}}$ IEC/EN 61204		60		
α_{Vo}	Temperature coefficient $\Delta V_o/\Delta T_C$ ($T_{C\text{ min}}$ to $T_{C\text{ max}}$)	$V_{i\text{ min}} - V_{i\text{ max}}$			± 3			± 4			± 5	mV/K	
		$I_o = 0 - I_{o\text{ nom}}$			± 0.02			± 0.02			± 0.02	%/K	

¹ Output set to 15 V with R-input.

Table 3d: Output data of PSS models. General conditions as per table 3a

Output			PSS369			PSS489			Unit		
Characteristics		Conditions	min	typ	max	min	typ	max			
V_o	Output voltage	$V_{i\text{ nom}}, I_{o\text{ nom}}$	35.78		36.22	47.71		48.29V	A		
I_o	Output current	$V_{i\text{ min}} - V_{i\text{ max}}$	0		9	0		9			
I_{oL}	Output current limit	$T_{C\text{ min}} - T_{C\text{ max}}$	9		11.25	9		11.25			
v_o	Output voltage noise	Switching freq.	$V_{i\text{ nom}}, I_{o\text{ nom}}$		35	60	$V_{i\text{ nom}}, I_{o\text{ nom}}$		35	60	mV _{pp}
		Total incl. spikes	IEC/EN 61204 BW = 20 MHz		39	64	IEC/EN 61204 BW = 20 MHz		39	64	
ΔV_{oV}	Static line regulation	$V_{i\text{ min}} - V_{i\text{ max}}, I_{o\text{ nom}}$	120		250	150		350	mV		
ΔV_{oI}	Static load regulation	$V_{i\text{ nom}}, I_o = 0 - I_{o\text{ nom}}$	60		120	70		150			
$v_{o d}$	Dynamic load regulation	Voltage deviat.	$V_{i\text{ nom}}$		200	$V_{i\text{ nom}}$		200	μs		
t_d		Recovery time	$I_{o\text{ nom}} \leftrightarrow 1/3 I_{o\text{ nom}}$ IEC/EN 61204		70	$I_{o\text{ nom}} \leftrightarrow 1/3 I_{o\text{ nom}}$ IEC/EN 61204		70			
α_{Vo}	Temperature coefficient $\Delta V_o/\Delta T_C$ ($T_{C\text{ min}}$ to $T_{C\text{ max}}$)	$V_{i\text{ min}} - V_{i\text{ max}}$			± 5			± 10	mV/K		
		$I_o = 0 - I_{o\text{ nom}}$			± 0.02			± 0.02	%/K		

Table 4a: Output data of PSK models. General conditions as per table 3a

Output			PSK3E25			PSK5A16			PSK5A20			PSK5A25			Unit
Characteristics		Conditions	min	typ	max	min	typ	max	min	typ	max	min	typ	max	
V_o	Output voltage	$V_{i\text{ nom}}, I_{o\text{ nom}}$	3.25		3.35	5.07		5.13	5.07		5.13	5.07		5.13	V
I_o	Output current	$V_{i\text{ min}} - V_{i\text{ max}}$	0		25	0		16	0		20			25	A
I_{oL}	Output current limit	$T_{C\text{ min}} - T_{C\text{ max}}$	25		31.5	16		20	20		25	25		31.5	
v_o	Output voltage noise	Switching freq.	$V_{i\text{ nom}}, I_{o\text{ nom}}$		20	40	$V_{i\text{ nom}}, I_{o\text{ nom}}$		20	40	$V_{i\text{ nom}}, I_{o\text{ nom}}$		20	40	mV _{pp}
		Total incl. spikes	IEC/EN 61204 BW = 20 MHz		24	44	IEC/EN 61204 BW = 20 MHz		24	44	IEC/EN 61204 BW = 20 MHz		24	44	
ΔV_{oV}	Static line regulation	$V_{i\text{ min}} - V_{i\text{ max}}, I_{o\text{ nom}}$	15		35	15		35	15		35	15		35	mV
ΔV_{oI}	Static load regulation	$V_{i\text{ nom}}, I_o = 0 - I_{o\text{ nom}}$	10		25	10		25	10		25	10		25	
$v_{o d}$	Dynamic load regulation	Voltage deviat.	$V_{i\text{ nom}}$		70	$V_{i\text{ nom}}$		70	$V_{i\text{ nom}}$		70	$V_{i\text{ nom}}$		70	μs
t_d		Recovery time	$I_{o\text{ nom}} \leftrightarrow 1/3 I_{o\text{ nom}}$ IEC/EN 61204		40	$I_{o\text{ nom}} \leftrightarrow 1/3 I_{o\text{ nom}}$ IEC/EN 61204		40	$I_{o\text{ nom}} \leftrightarrow 1/3 I_{o\text{ nom}}$ IEC/EN 61204		40	$I_{o\text{ nom}} \leftrightarrow 1/3 I_{o\text{ nom}}$ IEC/EN 61204		40	
α_{Vo}	Temperature coefficient $\Delta V_o/\Delta T_C$ ($T_{C\text{ min}}$ to $T_{C\text{ max}}$)	$V_{i\text{ min}} - V_{i\text{ max}}$			± 1			± 1			± 1			± 1	mV/K
		$I_o = 0 - I_{o\text{ nom}}$			± 0.02			± 0.02			± 0.02			± 0.02	%/K

Table 4b: Output data of PSK models. General conditions as per table 3a

Output			PSK1216			PSK1220			PSK1216 ¹			PSK1220 ¹			Unit	
Characteristics		Conditions	min	typ	max	min	typ	max	min	typ	max	min	typ	max		
V_o	Output voltage	$V_{i\text{ nom}}, I_o\text{ nom}$	11.93	12.07		11.93	12.07		14.91	15.09		14.91	15.09	V		
I_o	Output current	$V_{i\text{ min}} - V_{i\text{ max}}$	0	16		0	20		0	16			20	A		
I_{oL}	Output current limit	$T_{C\text{ min}} - T_{C\text{ max}}$	16	20		20	25		16	20		20	25			
v_o	Output voltage noise	Switching freq.	$V_{i\text{ nom}}, I_o\text{ nom}$		25	45		25	45		30	50		30	50	mV _{pp}
		Total incl. spikes	IEC/EN 61204 BW = 20 MHz		29	49		29	49		34	54		34	54	
ΔV_{oV}	Static line regulation	$V_{i\text{ min}} - V_{i\text{ max}}, I_o\text{ nom}$	40	70		40	70		50	80		50	80	mV		
ΔV_{oI}	Static load regulation	$V_{i\text{ nom}}, I_o = 0 - I_o\text{ nom}$	30	50		30	50		35	55		30	55			
$v_{o d}$	Dynamic load regulation	Voltage deviat.	$V_{i\text{ nom}}$		140		140		150		150		150			
t_d		Recovery time	$I_o\text{ nom} \leftrightarrow 1/3 I_o\text{ nom}$ IEC/EN 61204		60		60		60		60		60	μs		
α_{Vo}	Temperature coefficient $\Delta V_o/\Delta T_C$ ($T_{C\text{ min}}$ to $T_{C\text{ max}}$)	$V_{i\text{ min}} - V_{i\text{ max}}$			± 3		± 3		± 4		± 4		± 4	mV/K		
		$I_o = 0 - I_o\text{ nom}$			± 0.02		± 0.02		± 0.02		± 0.02		± 0.02	%/K		

¹ Output set to 15 V with R-input.

Table 4c: Output data of PSK models. General conditions as per table 3a

Output			PSK2416			PSK2420			PSK3616			PSK3620			Unit	
Characteristics		Conditions	min	typ	max	min	typ	max	min	typ	max	min	typ	max		
V_o	Output voltage	$V_{i\text{ nom}}, I_o\text{ nom}$	23.88	24.14		23.86	24.14		35.78	36.22		35.78	36.22	V		
I_o	Output current	$V_{i\text{ min}} - V_{i\text{ max}}$	0	16		0	20		0	16			20	A		
I_{oL}	Output current limit	$T_{C\text{ min}} - T_{C\text{ max}}$	16	20		20	25		16	20		20	25			
v_o	Output voltage noise	Switching freq.	$V_{i\text{ nom}}, I_o\text{ nom}$		30	60		30	60		35	60		35	60	mV _{pp}
		Total incl. spikes	IEC/EN 61204 BW = 20 MHz		34	64		34	64		39	64		39	64	
ΔV_{oV}	Static line regulation	$V_{i\text{ min}} - V_{i\text{ max}}, I_o\text{ nom}$	80	170		80	170		120	250		120	250	mV		
ΔV_{oI}	Static load regulation	$V_{i\text{ nom}}, I_o = 0 - I_o\text{ nom}$	50	120		50	120		60	200		60	200			
$v_{o d}$	Dynamic load regulation	Voltage deviat.	$V_{i\text{ nom}}$		180		180		200		200		200			
t_d		Recovery time	$I_o\text{ nom} \leftrightarrow 1/3 I_o\text{ nom}$ IEC/EN 61204		60		60		70		70		70	μs		
α_{Vo}	Temperature coefficient $\Delta V_o/\Delta T_C$ ($T_{C\text{ min}}$ to $T_{C\text{ max}}$)	$V_{i\text{ min}} - V_{i\text{ max}}$			± 5		± 5		± 8		± 8		± 8	mV/K		
		$I_o = 0 - I_o\text{ nom}$			± 0.02		± 0.02		± 0.02		± 0.02		± 0.02	%/K		

Table 4d: Output data of PSK models. General conditions as per table 3a

Output			PSK1212			PSK1212 ¹			PSK2424			Unit	
Characteristics		Conditions	min	typ	max	min	typ	max	min	typ	max		
V_o	Output voltage	$V_{i\text{ nom}}, I_o\text{ nom}$	11.93	12.07		14.91	15.09		23.86	24.14		V	
I_o	Output current	$V_{i\text{ min}} - V_{i\text{ max}}$	0	12		0	12		0	12		A	
I_{oL}	Output current limit	$T_{C\text{ min}} - T_{C\text{ max}}$	12	15		12	15		12	15			
v_o	Output voltage noise	Switching freq.	$V_{i\text{ nom}}, I_o\text{ nom}$		25	50		30	60		35	60	mV _{pp}
		Total incl. spikes	IEC/EN 61204 BW = 20 MHz		29	54		34	64		39	65	
ΔV_{oV}	Static line regulation	$V_{i\text{ min}} - V_{i\text{ max}}, I_o\text{ nom}$	40	70		50	80		80	170		mV	
ΔV_{oI}	Static load regulation	$V_{i\text{ nom}}, I_o = 0 - I_o\text{ nom}$	30	50		40	60		50	120			
$v_{o d}$	Dynamic load regulation	Voltage deviat.	$V_{i\text{ nom}}$		140		140		180		180		
t_d		Recovery time	$I_o\text{ nom} \leftrightarrow 1/3 I_o\text{ nom}$ IEC/EN 61204		60		60		60		60	μs	
α_{Vo}	Temperature coefficient $\Delta V_o/\Delta T_C$ ($T_{C\text{ min}}$ to $T_{C\text{ max}}$)	$V_{i\text{ min}} - V_{i\text{ max}}$			± 3		± 4		± 5		± 5	mV/K	
		$I_o = 0 - I_o\text{ nom}$			± 0.02		± 0.02		± 0.02		± 0.02	%/K	

¹ Output set to 15 V with R-input

Table 4e: Output data of PSK models. General conditions as per table 3a

Output		Conditions	PSK3612			PSK4812		Unit
Characteristics			min	typ	max	min	typ	
V_o	Output voltage	$V_{i\ nom}, I_o\ nom$	35.78	36.22	47.71	48.29V		
I_o	Output current	$V_{i\ min} - V_{i\ max}$	0	12	0	12		A
I_{oL}	Output current limit	$T_C\ min - T_C\ max$	12	15	12	15		
v_o	Output voltage noise	Switching freq.	$V_{i\ nom}, I_o\ nom$		$V_{i\ nom}, I_o\ nom$		mV _{pp}	
		Total incl. spikes	IEC/EN 61204 BW = 20 MHz		IEC/EN 61204 BW = 20 MHz			
ΔV_{oV}	Static line regulation	$V_{i\ min} - V_{i\ max}, I_o\ nom$	120	250	150	350		mV
ΔV_{oI}	Static load regulation	$V_{i\ nom}, I_o = 0 - I_o\ nom$	60	120	70	150		
v_{oD}	Dynamic load regulation	Voltage deviat.	$V_{i\ nom}$		$V_{i\ nom}$		μs	
t_d		Recovery time	$I_o\ nom \leftrightarrow 1/3 I_o\ nom$		$I_o\ nom \leftrightarrow 1/3 I_o\ nom$			
α_{V_o}	Temperature coefficient $\Delta V_o / \Delta T_C$ ($T_C\ min$ to $T_C\ max$)	$V_{i\ min} - V_{i\ max}$	± 5		± 10		mV/K	
		$I_o = 0 - I_o\ nom$	± 0.02		± 0.02		%/K	

Output Voltage Regulation

The dynamic load regulation is shown in fig. 2

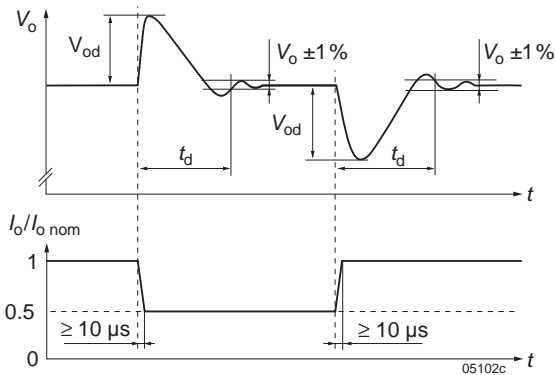

Fig. 2
Dynamic load regulation.

Output Protection

A voltage suppressor diode, which in worst case conditions fails into a short-circuit, protects the output against an internally generated overvoltage. Such an overvoltage could occur due to a failure of either the control circuit or the switching transistor. The output protection is not designed to withstand externally applied overvoltages.

Current Limitation

A constant current limitation circuit holds the output current I_o almost constant in the area of 100 to 120% of $I_o\ nom$, when an overload or a short-circuit is applied to the output. It acts self-protecting and recovers – in contrary to the fold back method – automatically after removal of the overload or short-circuit condition.

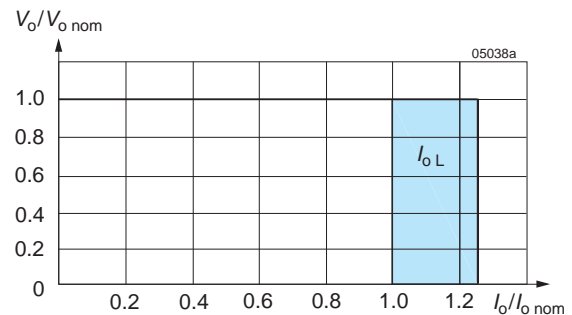

Fig. 3
Overload, short-circuit behaviour V_o versus I_o .

Parallel and Series Connection

Outputs of equal nominal voltage may be parallel-connected. Interconnect the current sharing pins T (pin 22) for even distribution of the output current; see *Auxiliary Functions*.

Outputs can be series-connected with any other regulator, provided that the regulators are powered by electrically isolated source voltages. In series connection the maximum output current is limited by the lowest current limitation.

Thermal Considerations and Protection

When a switching regulator is located in free, quasi-stationary air (convection cooling) at a temperature $T_{A \max}$ and is operated at its nominal output current $I_{o \text{ nom}}$, the case temperature T_C can rise over $T_{C \max}$ after the warm-up phase. T_C is measured at the measuring point of case temperature; see *Mechanical Data*.

Under practical operating conditions, the ambient temperature T_A may exceed $T_{A \max}$, provided that additional measures (heat

sink, forced cooling, etc.) are taken to ensure that the case temperature T_C does not exceed its maximum value.

The regulator is protected by an internal temperature sensor, which inhibits the output above $T_{C \max}$. The output automatically recovers, when the temperature drops below $T_{C \max}$.

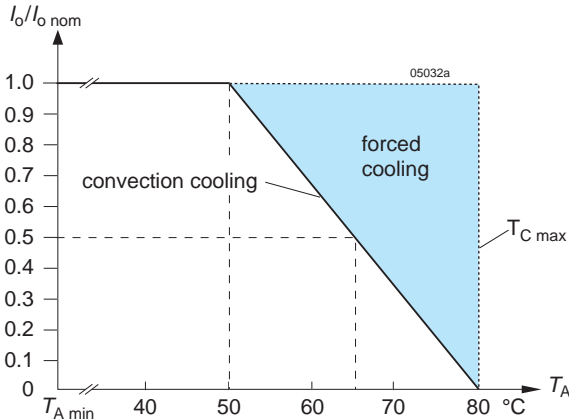

Fig. 4a
Output current derating versus temperature (models -2)

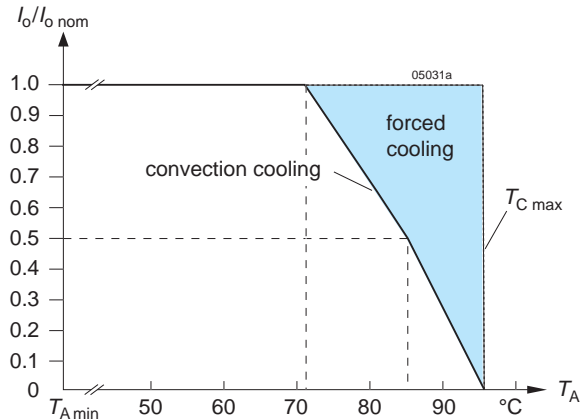

Fig. 4b
Output current derating versus temperature (models -7 or -9).

Auxiliary Functions

Inhibit (Remote On / Off)

The inhibit input allows to enable or disable the output with a control signal. In systems with several regulations, this feature can be used to control the activation sequence of the regulators by a logic signal (TTL, C-MOS, etc.). An output voltage overshoot will not occur, when switching on or off.

The inhibit signal is referenced to the S- (pin 18). The signal i and the switching times are specified in table 5, fig. 5, and fig. 6.

Note: With open i input, the output is enabled.

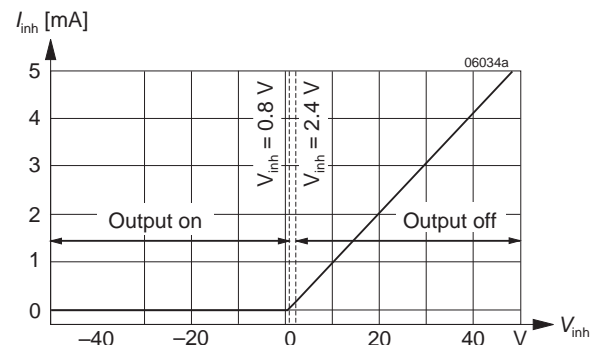

Fig. 5
Specification of the inhibit signal (typical)

Table 5: Inhibit characteristics

Characteristics		Conditions	min	typ	max	Unit
V_{inh}	Inhibit input voltage	$V_o = \text{on}$	$V_{i \text{ min}} - V_{i \text{ max}}$	-50	+0.8	V
		$V_o = \text{off}$	$T_{C \text{ min}} - T_{C \text{ max}}$	+2.4	+50	
t_r	Switch-on time	$V_i = V_{i \text{ nom}}$		130		ms
t_f	Switch-off time	$R_L = V_o \text{ nom} / I_o \text{ nom}$		25		
$I_{i \text{ inh}}$	Input current when inhibited	$V_i = V_{i \text{ nom}}$		25		mA

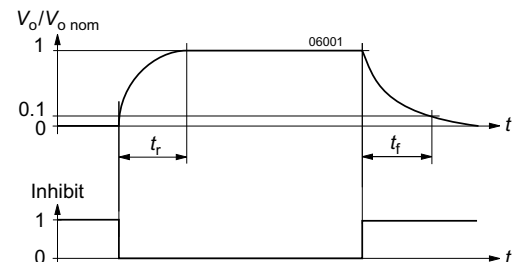

Fig. 6
Output response as a function of the inhibit signal

Sense Lines

This feature enables compensation of the voltage drop across the connector contacts and the load lines. If the sense lines are connected at the load rather than directly at the connector, the user must ensure that $V_{o,max}$ (between V_{o+} and $Go-$) is not exceeded.

Applying generously dimensioned cross-section load leads reduces the voltage drop. To minimize noise pick-up, the sense lines should be wired in parallel or twisted.

To ensure correct operation, both sense lines must be connected to their respective power output. The voltage difference between any sense line and its respective power output pin (as measured on the connector) should not exceed the values given in table 4.

Note: Sense lines should always be connected! It is recommended to connect the sense lines directly at the female connector.

Table 6: Allowed voltage compensation using sense lines

Nominal output voltage	Total voltage difference between both sense lines and their respective output	Voltage difference between $Go-$ and $S-$
3.3 V, 5.1 V	≤ 0.5 V	≤ 0.25 V
12 – 48 V	≤ 1.0 V	≤ 0.25 V

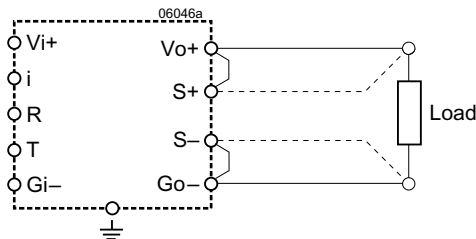

Fig. 7
Sense lines connection

Current Sharing

For parallel operation of several regulators, interconnect all T-pins to ensure that the output currents are evenly distributed. This feature improves transient load performance and increases system reliability. All paralleled regulators should be supplied by equal input voltage (V_i). The output lines should exhibit equal length and cross section to provide equal voltage drop.

Table 7: Maximum adjustable output voltage

$V_{o,nom}$	Nominal Output Volt.	Conditions	3.3 V min typ	5.1 V min typ	12/15 V min typ	24 V min typ	36 V min typ	48 V min typ	Unit
$V_{o,max}$	Maximum adjustable output voltage with R-input	$V_{i,nom}, I_{o,nom}$??	5.6	16	26	42.5	52.8	V

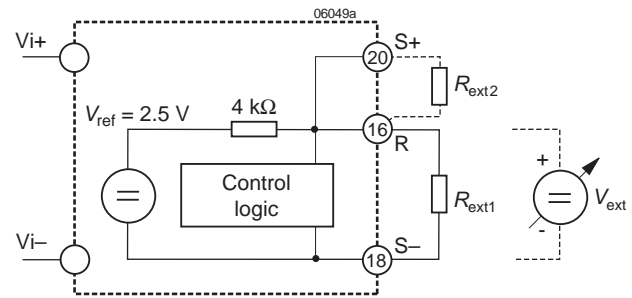

Fig. 8
Voltage adjustment via R-input

R Control (Output Voltage Adjust)

Note: With open R input, $V_o \approx V_{o,nom}$.

The output voltage V_o can either be adjusted with an external voltage source (V_{ext}) or with an external resistor (R_1 or R_2). The adjustment range is 0 – $V_{o,max}$. The minimum differential voltage $\Delta V_{i0,min}$ between input and output (see *Electrical Input Data*) should be maintained.

a) $V_o = 0 - V_{o,max}$, using V_{ext} between R and $S-$:

$$V_{ext} \approx 2.5 \text{ V} \cdot \frac{V_o}{V_{o,nom}} \quad V_o \approx V_{o,nom} \cdot \frac{V_{ext}}{2.5 \text{ V}}$$

Caution: To prevent damage V_{ext} should not exceed 20 V, nor be negative.

b) $V_o = 0$ to $V_{o,nom}$, using R_1 between R and $S-$:

$$R_1 \approx \frac{4000 \Omega \cdot V_o}{V_{o,nom} - V_o} \quad V_o \approx \frac{V_{o,nom} \cdot R_1}{R_1 + 4000 \Omega}$$

c) $V_o = V_{o,nom}$ to $V_{o,max}$, using R_2 between R and $S+$:

$$R_2 \approx \frac{4000 \Omega \cdot V_o \cdot (V_{o,nom} - 2.5 \text{ V})}{2.5 \text{ V} \cdot (V_o - V_{o,nom})}$$

$$V_o \approx \frac{V_{o,nom} \cdot 2.5 \text{ V} \cdot R_2}{2.5 \text{ V} \cdot (R_2 + 4000 \Omega) - V_{o,nom} \cdot 4000 \Omega}$$

Caution: To prevent damage, R_2 should never be less than 47 kΩ.

Test Sockets

Test sockets (pin $\varnothing = 2$ mm) for measuring the output voltage V_o at the sense lines, are located at the front side of the regulator. The test sockets are protected by a series resistor.

LED Output Voltage Indicator

A green indicator LED illuminates, when the output voltage is present.

Electromagnetic Compatibility (EMC)

Electromagnetic Immunity

General condition: Case not earthed.

Table 8: Immunity type tests

Phenomenon	Standard	Class Level	Coupling mode ¹	Value applied	Waveform	Source imped.	Test procedure	In oper.	Per-form. ⁴
Direct transients ²	IEC 60571-1	2	i/c, +i/-i	800 V _p	100 μs	100 Ω	1 pos. and 1 neg. voltage surge per coupling mode	yes	B
				1500 V _p	50 μs				
				3000 V _p	5 μs				
				4000 V _p	1 μs				
				7000 V _p	100 ns				
Electrostatic discharge	IEC/EN 61000-4-2	4 ² 3 ³	contact discharge to case	8000 V _p ² 6000 V _p ³	1/50 ns	330 Ω	10 positive and 10 negative discharges	yes	A
Electromagnetic field	IEC/EN 61000-4-3	3 ² 2 ³	antenna	10 V/m ² 3 V/m ³	AM 80% 1 kHz		80 – 1000 MHz	yes	A
Electrical fast transients/burst	IEC/EN 61000-4-4	3 ² 2 ³	i/c, +i/-i	2000 V _p ² 1000 V _p ³	bursts of 5/50 ns 5 kHz rep. rate transients with 15 ms burst duration and 300 ms period	50 Ω	60 s positive 60 s negative transients per coupling mode	yes	A
		4 ² 3 ³		4000 V _p ² 2000 V _p ³					
Surges	IEC/EN 61000-4-5	3 ² 2 ³	i/c	2000 V _p ² 1000 V _p ³	1.2/50 μs	12 Ω	5 pos. and 5 neg. surges per coupling mode	yes	A
		3 ² 2 ³	+i/-i	2000 V _p ² 500 V _p ³	1.2/50 μs	12 Ω			
Conducted disturbances	IEC/EN 61000-4-6	3 ² 2 ³	i, o, signal wires	10 VAC ² 3 VAC ³	AM 80% 1 kHz	150 Ω	0.15 – 80 MHz	yes	A

¹ i = input, o = output, c = case

² Not applicable for -2 models

³ Valid for -2 models

⁴ A = Normal operation, no deviation from specifications, B = Normal operation, temporary loss of function or deviation from specs possible

⁵ With option C, manual reset might be necessary.

Electromagnetic Emissions

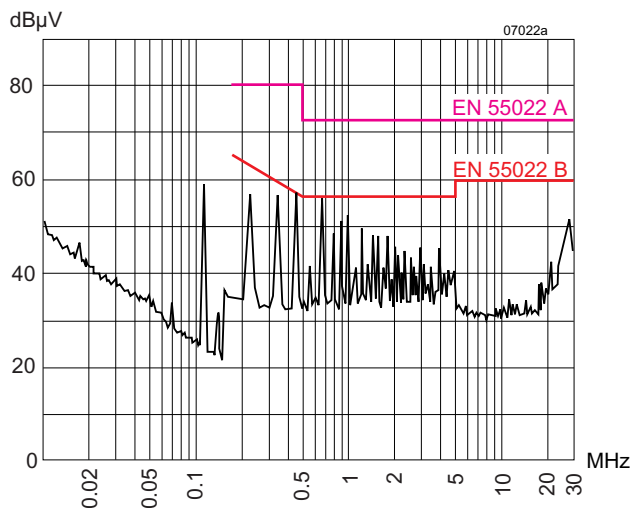

Fig. 9
Typical disturbance voltage
(quasi-peak) at the input
according to EN 55011/22
measured at $V_{i\text{nom}}$ and $I_{o\text{nom}}$.

Immunity to Environmental Conditions

Table 9: Mechanical and climatic stress

Test Method		Standard	Test Conditions		Status
Cab	Damp heat steady state	IEC/EN 60068-2-78 MIL-STD-810D section 507.2	Temperature: Relative humidity: Duration:	40 ±2 °C 93 +2/-3 % 56 days	Regulator not operating
Ea	Shock (half-sinusoidal)	IEC/EN 60068-2-27 MIL-STD-810D section 516.3	Acceleration amplitude: Bump duration: Number of bumps:	50 g _n = 490 m/s ² 11 ms 18 (3 each direction)	Regulator operating
Eb	Bump (half-sinusoidal)	IEC/EN 60068-2-29 MIL-STD-810D section 516.3	Acceleration amplitude: Bump duration: Number of bumps:	25 g _n = 245 m/s ² 11 ms 6000 (1000 each direction)	Regulator operating
Fc	Vibration (sinusoidal)	IEC/EN 60068-2-6 MIL-STD-810D section 514.3	Acceleration amplitude: Frequency (1 Oct/min): Test duration:	0.35 mm (10 – 60 Hz) 5 g _n = 49 m/s ² (60 – 2000 Hz) 10 – 2000 Hz 7.5 h (2.5 h each axis)	Regulator operating
Fda	Random vibration wide band Reproducibility high	IEC/EN 60068-2-35 DIN 40046 part 23	Acceleration spectral density: Frequency band: Acceleration magnitude: Test duration:	0.05 g ² /Hz 20 – 500 Hz 4.9 g _{n,rms} 3 h (1 h each axis)	Regulator operating
Kb	Salt mist, cyclic (sodium chloride NaCl solution)	IEC/EN 60068-2-52	Concentration: Duration: Storage: Storage duration: Number of cycles:	5% (30 °C) 2 h per cycle 40 °C, 93% rel. humidity 22 h per cycle 3	Regulator not operating

Temperatures

Table 10: Temperature specifications, valid for an air pressure of 800 - 1200 hPa (800 - 1200 mbar)

Temperature		-2		-7		-9 (Option)		Unit
Characteristics	Conditions	min	max	min	max	min	max	
T _A	Ambient temperature ¹	-10	50	-25	71	-40	71	°C
T _C	Case temperature							
T _S	Storage temperature ¹	-25	100	-40	100	-55	100	

¹ See *Thermal Considerations* and *Overtemperature Protection*.

Reliability

Table 11: MTBF and device hours

MTBF	Ground Benign	Ground Fixed		Ground Mobile	Device Hours ¹
MTBF acc. to MIL-HDBK-217F	T _C = 40 °C	T _C = 40 °C	T _C = 70 °C	T _C = 50 °C	2 100 000 h
	335 000 h	138 000 h	35 000 h	33 000 h	

¹ Statistical values, based on an average of 4300 working hours per year and in general field use

Mechanical Data

PSS Models

The regulators are designed to be inserted into a rack according to IEC 60297-3. Dimensions in mm.

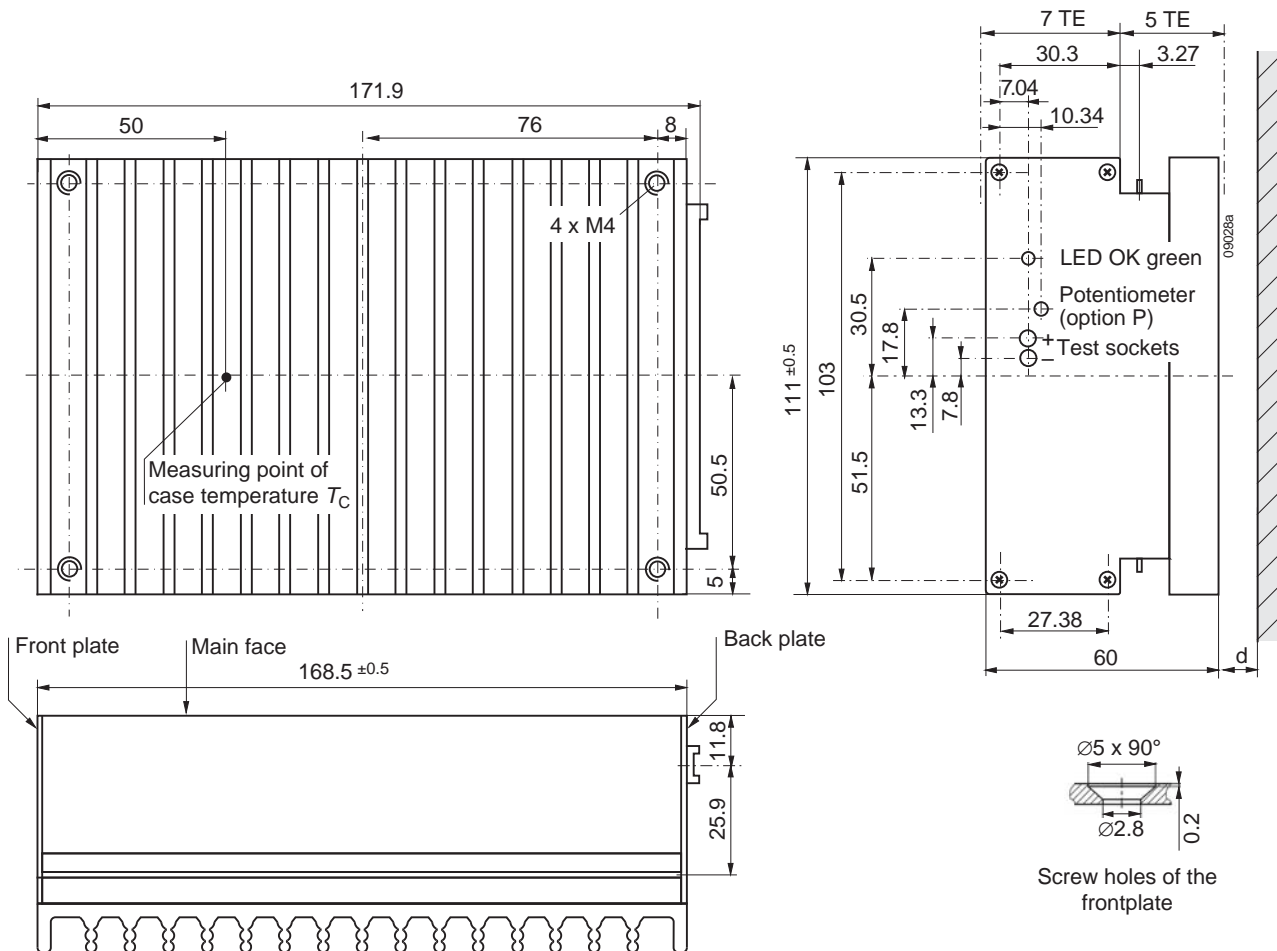

Fig. 10
Case S01 for PSS models; weight 1.3 kg
Aluminium, fully enclosed, black finish EP power-coated, and self cooling.

Notes:

- $d \geq 15$ mm, recommended minimum distance to next part to ensure proper air circulation at full output power.
- Free air locations: the regulator should be mounted with its fins in vertical position to achieve a maximum air flow through heat sink.

PSK Models

The regulators are designed to be inserted into a rack according to IEC 60297-3. Dimensions in mm.

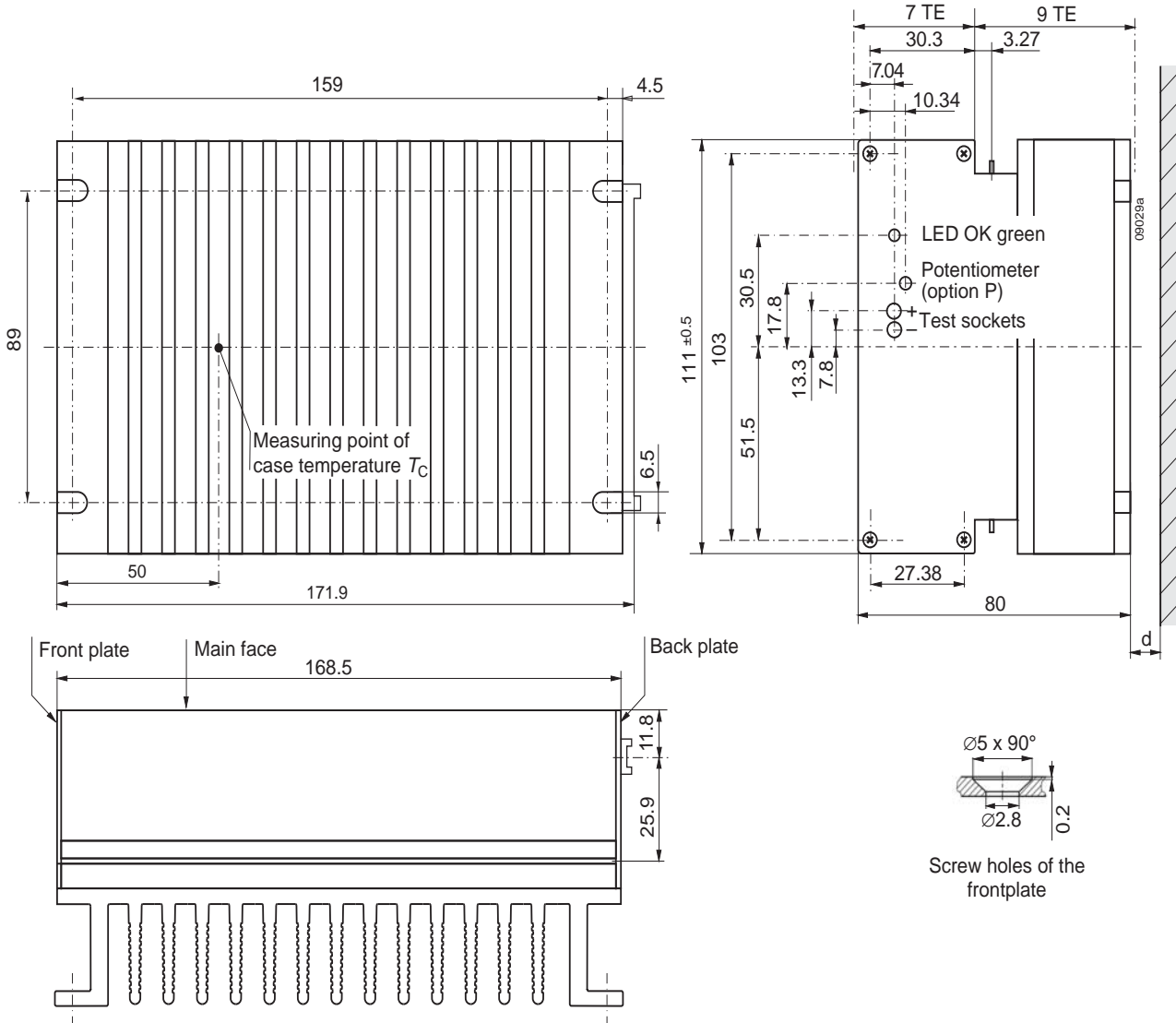

Fig. 11
Case K01 for PSK models, weight 1.6 kg
Aluminium, fully enclosed, black finish EP power-coated, and self cooling.

Notes:

- $d \geq 15$ mm, recommended minimum distance to next part to ensure proper air circulation at full output power.
- Free air locations: the regulator should be mounted with its fins in vertical position to achieve a maximum air flow through heat sink.

Safety and Installation Instructions

Connector Pin Allocation

The connector pin allocation table defines the electrical potentials and the physical pin positions on the H15 or H15S4 connector. Pin 24 (protective earth) is a leading pin, which provides electrical contact first. The regulators should only be wired via the female connector H15 (according to DIN 41612) to ensure requested safety!

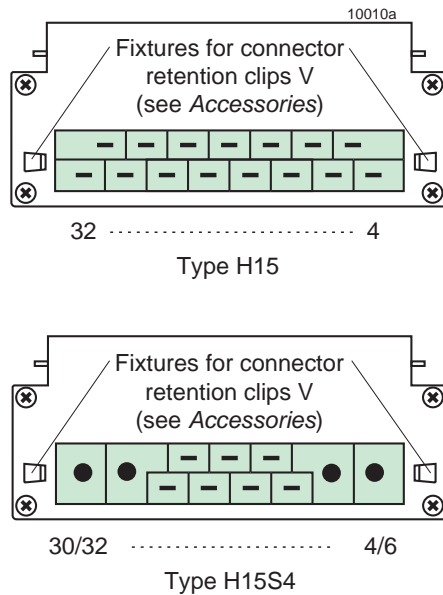

Fig. 12
View of H15 and H15S4 male connector

Table 12: H15 and H15S4 connector pin allocation

Electrical Determination	Type H15		Type H15S4	
	Pin no.	Ident.	Pin no.	Ident.
Output voltage (positive)	4	Vo+	4/6	Vo+
Output voltage (positive)	6	Vo+		
Output voltage (negative)	8	Go-	8/10	Go-
Output voltage (negative)	10	Go-		
Crowbar trigger input (option C)	12	C	12	C
Inhibit input	14	i	14	i
R-input (output voltage programming) ¹	16	R ¹	16	R ¹
Sense line (negative)	18	S-	18	S-
Sense line (positive)	20	S+	20	S+
Current sharing control input	22	T	22	T
Protective ground (leading pin)	24	⊕	24	⊕
Input voltage (negative)	26	Gi-	26/28	Gi-
Input voltage (negative)	28	Gi-		
Input voltage (positive)	30	Vi+	30/32	Vi+
Input voltage (positive)	32	Vi+		

¹ Not available with option P

Installation Instruction

Installation of the regulators must strictly follow the national safety regulations in compliance with the enclosure, mounting, creepage, clearance, casualty, markings, and segregation requirements of the end-use application.

The input and the output circuit are not separated. The negative path is internally interconnected.

The regulators should be connected to a secondary circuit. Make sure that a regulator failure (e.g. by an internal short-circuit) does not result in a hazardous condition.

Do not open the regulator!

Standards and Approvals

All switching regulators are class-I equipments and have been approved according to UL 60950, CSA 60950, and IEC/EN 60950.

The regulators have been evaluated for:

- Building in
- Operational insulation from input to output and input/output to case
- The use in a pollution degree 2 environment
- Connecting the input to a secondary circuit, which is subject to a maximum transient rating of 1500 V.

The switching regulators are subject to manufacturing surveillance in accordance with the above mentioned standards and with ISO 9001:2000.

Cleaning Agents

In order to avoid possible damage, any penetration of cleaning fluids must be prevented, since the regulators are not hermetically sealed.

Protection Degree

The protection degree is IP 30 (IP 20, if equipped with option P). It applies only, if the regulator is plugged-in or the matching female connector is properly attached.

Isolation and Protective Earth

The resistance of the protective earth connection (max. 0.1 Ω) is tested. Also the electric strength between the input interconnected with the output and the case is tested with 500 VDC (all -2 models), 750 VDC (models with $V_{i\max} = 80$ V), or 1500 VDC (models with $V_{i\max} = 144$), ≥ 1 s.

These tests are performed in the factory as routine test in accordance with EN 50116 and IEC/EN 60950. The electric strength test should not be repeated by the customer. Power-One will not honor any warranty claims resulting from electric strength tests.

Railway Application

The regulators have been developed observing the railway standards EN 50155 and EN 50121. All boards are coated with a protective lacquer.

Description of Options

-9 Extended Temperature Range

This option defines an extended temperature range as specified in table 10.

P Potentiometer to Adjust the Output

Note: Option P is not recommended, if several regulators are operated in parallel connection.

Option P excludes R function; the R-input (pin 16) should be left open-circuit. The output voltage V_o can be adjusted in the range 90 - 110% of $V_{o\ nom}$.

However, the minimum differential voltage $V_{i\ max}$ between input and output as specified in *Electrical Input Data* should be maintained.

E Inrush Current Limitation

Note: This option requires an increased minimum input voltage $V_{i\ max}$ of up to 1 V, dependent upon input range.

In regulators without option E, after application of the input supply the inrush current is limited by parasitic components of the voltage source and the regulator input only. The regulator input exhibits a very low impedance, and when driven from a low impedance source, for example a battery, the inrush current can peak at several orders of magnitude above the continuous input current.

Option E dramatically reduces this peak current and is recommended for any application to protect series elements such as fuses, switches, or circuit breakers. The startup circuit is bypassed during normal operation.

C Thyristor Crowbar

Note: The crowbar can be reset by removal of the input voltage only. The inhibit signal cannot deactivate the thyristor.

Option C protects the load against power supply malfunction. It is not designed to sink external currents.

As a central overvoltage protection device, the crowbar is usually connected to the external load via distributed inductance of the lines. For this reason, the overvoltage at the load can temporarily exceed the trigger voltage $V_{o\ c}$.

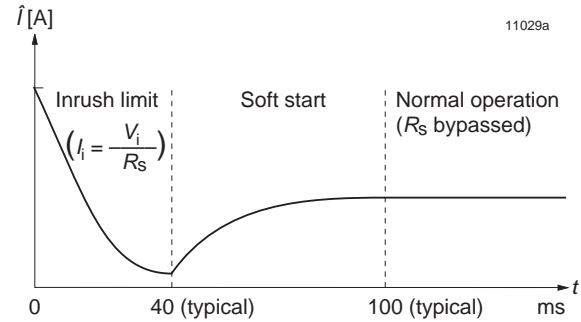

Fig. 13

Option E: Inrush current versus time. R_s is the startup resistor ($R_s = 1 \Omega$ for models with $V_{i\ max} \leq 80 V$, $R_s = 15 \Omega$ for models with $V_{i\ max} > 80 V$)

Depending on the application, further decentralized overvoltage protection elements may have to be used additionally.

A fixed-value monitoring circuit checks the output voltage V_o , and when the trigger voltage $V_{o\ c}$ is reached, the thyristor crowbar triggers and disables the output.

An external connection C (crowbar trigger control) is provided. When crowbar option is used with two or more power supplies in parallel connection, all crowbar trigger terminals (C) should be interconnected. This ensures all crowbar circuits triggering simultaneously, in order to disable all outputs at once. The crowbar trigger voltage is maintained between V_{o+} and $Go-$. To prevent false triggering, the user should ensure that V_o (between V_{o+} and $Go-$) does not exceed $V_{o\ c}$.

G RoHS Compliance

Models with G are RoHS-compliant for all six substances.

Table 13: Crowbar trigger levels

Characteristics	Conditions	PSS5A12 PSK5A16 PSK5A20 PSK5A25			PSS129 PSS1212 PSK1212 PSK1216 PSK1220			PSS249 PSS2412 PSK2412 PSK2416 PSK2420			PSS369 PSS3612 PSK3612 PSK3616 PSK3620			PSS 489 PSK 4812		Unit
		min	typ	max	min	typ	max	min	typ	max	min	typ	max	min	typ	
$V_{o\ c}$	Trigger voltage	$T_{C\ min} - T_{C\ max}$		6.3	6.7	17.8	18.9	28.89	30.6	47	50	63	67		V	
		$V_{i\ min} - V_{i\ max}$				14.3 ¹	15.2 ¹			43 ¹	45.5 ¹					
t_s	Delay time	$I_o = 0 - I_{o\ nom}$		1.5		1.5		1.5		1.5		1.5			μs	

¹ Models with option P

B, B1 Cooling Plate

Where a cooling surface is available, a cooling plate (option B or option B1) can be fitted instead of the standard heatsink. The mounting system must ensure sufficient cooling capacity

to guarantee that the maximum case temperature $T_{C \max}$ is not exceeded. The required cooling capacity can be calculated by the following formula:

$$P_{\text{Loss}} = \frac{100\% - \eta}{\eta} \cdot (V_o \cdot I_o)$$

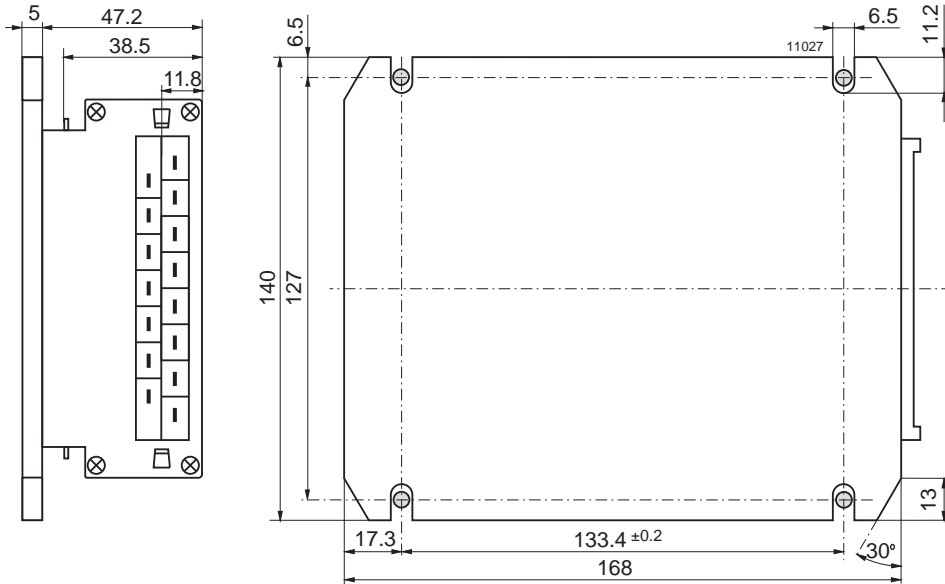

Fig. 14
Option B, large cooling plate
Weight: 1.3 kg

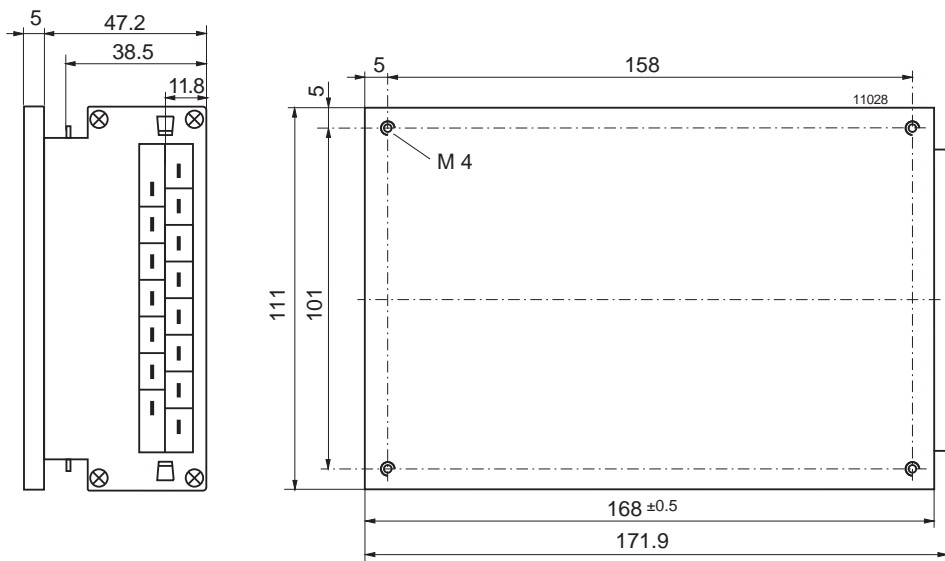

Fig. 15
Option B1, small cooling plate
Weight: 1.2 kg

Accessories

A variety of electrical and mechanical accessories are available including:

- Various mating connectors H15 and H15S4 including fast-on, screw, solder or press-fit terminals, code key system and coding clips [HZZ00202]
- Connector retention brackets CRB [HZZ01216]
- Connector retention clips V [HZZ01209]
- Cable connector housing (cable hood) KSG-H15/H15S4 [HZZ00141], also available with fixation [HZZ00142]
- Various front panels for 19" racks with 3U height, 12 or 16 TE, Schroff or Intermas
- Wall-mounting plate K02 [HZZ01213] for models with option B1
- Brackets for DIN-rail and wall mounting [HZZ00610]
- DIN-rail mounting assembly DMB-K/S [HZZ0615]
- Additional external input and output filters
- Battery sensor [S-KSMH...] for using the converter as a battery charger. Different cell characteristics can be selected; see *Battery Charging/Temperature Sensor*

For additional accessory product information, see the accessory data sheets listed with each product series or individual model listing at www.power-one.com.



DIN-rail mounting assembly DMB-K/S



Wall-mounting plate MOUNTINGPLATE-K02



H15 female connector, code key system



Connector retention clip V

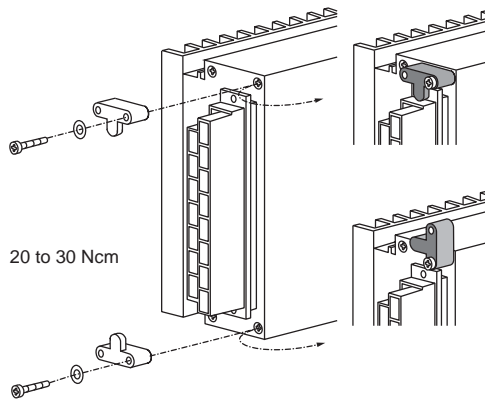

Connector retention brackets CRB



Front panels

NUCLEAR AND MEDICAL APPLICATIONS - Power-One products are not designed, intended for use in, or authorized for use as critical components in life support systems, equipment used in hazardous environments, or nuclear control systems without the express written consent of the respective divisional president of Power-One, Inc.

TECHNICAL REVISIONS - The appearance of products, including safety agency certifications pictured on labels, may change depending on the date manufactured. Specifications are subject to change without notice.

EC Declaration of Conformity

We

Power-One AG
Ackerstrasse 56 CH-8610 Uster

declare under our sole responsibility that all PSx Series switching regulators carrying the CE-mark are in conformity with the provisions of the Low Voltage Directive (LVD) 2006/95/EC of the European Communities..

Conformity with the directive is presumed by conformity with the following harmonized standards:

- EN 61204: 1995 (= IEC 61204: 1993, modified)
Low-voltage power supply devices, DC output - Performance characteristics and safety requirements
- EN 60950: 1992 + A1: 1993 + A2 (= IEC 950 second edition 1991 + A1: 1992 + A2: 1993) - Safety of information technology equipment

The installation instructions given in the corresponding data sheet describe correct installation leading to the presumption of conformity of the end product with the LVD. All PSx Series Switching Regulators are components, intended exclusively for inclusion within other equipment by an industrial assembly operation or by professional installers. They must not be operated as stand alone products.

Hence conformity with the Electromagnetic Compatibility Directive 89/336/EEC (EMC Directive) needs not to be declared. Nevertheless, guidance is provided in most product application notes on how conformity of the end product with the indicated EMC standards under the responsibility of the installer can be achieved, from which conformity with the EMC directive can be presumed.

Uster, 1-Sep-2006

Power-One AG



Rolf Baldauf
Director Engineering



Johann Milavec
Director Projects and IP