



## NXP - OM11043 - MCU - Prototyping Board

### Product Overview:

The embed NXP LPC1768 board lets you create prototypes without having to work with low-level microcontroller details, so you can experiment and iterate faster than ever. Designers compose and compile embedded software using a browser-based IDE, then download it quickly and easily, using a simple drag-and-drop function, to the board's NXP Cortex-M3 microcontroller LPC1768.

Engineers new to embedded applications can use the board to prototype real products incorporating microcontrollers, while experienced engineers can use it to be more productive in early stages of development. The embed tools are designed to let you try out new ideas quickly, in much the same way that an architect uses a pencil and paper to sketch out concepts before turning to an advanced CAD program to implement a design.

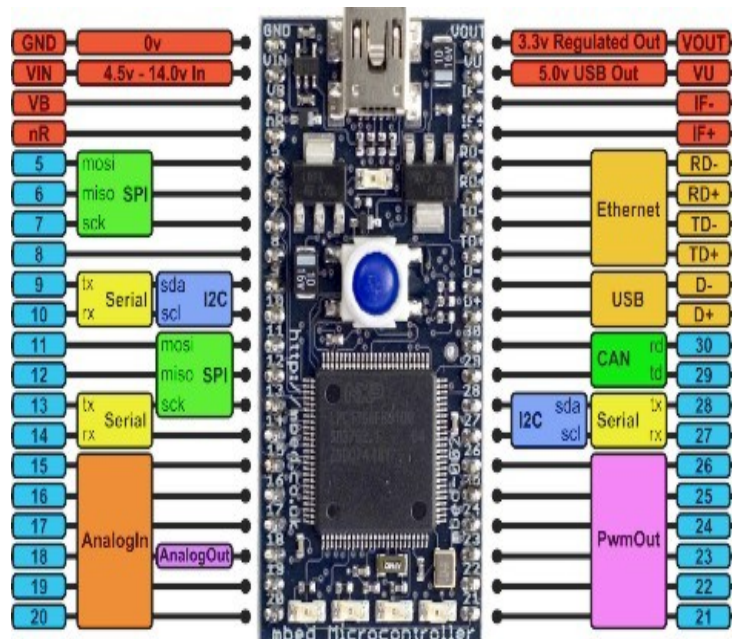

### Key Features:

- Convenient form-factor: 40-pin DIP, 0.1-inch pitch
- Drag-and-drop programming, with the board represented as a USB drive
- Best-in-class Cortex-M3 hardware
  - 100 MHz ARM with 64 KB of SRAM, 512 KB of Flash
  - Ethernet, USB OTG
  - SPI, I2C, UART, CAN
  - GPIO, PWM, ADC, DAC
- Easy-to-use online tools
  - Web-based C/C++ programming environment
  - Uses the ARM Real View compile engine
  - API-driven development using libraries with intuitive interfaces

- Comprehensive help and online community

## Ordering Information:

### Products:

Part Number	Manufacturer	Farnell P/N	Newark P/N
OM11043	NXP	1761179	33R0887

### Associated Products:

Part Number	Manufacturer	Description	Farnell P/N	Newark P/N
LPC1764FBD100	NXP	ARM Cortex-M3 microcontroller with 128KB flash, 32KB SRAM, 10/100 Ethernet, 2 CAN, 12-bit ADC	1718546	15R1837
LPC1765FBD100	NXP	ARM Cortex-M3 microcontroller with 256KB flash, 64KB SRAM, USB 2.0 Host/Device/OTG, 2 CAN, I <sup>2</sup> S, 12-bit ADC, 10-bit DAC	1718547	15R1838
LPC1766FBD100	NXP	ARM Cortex-M3 microcontroller with 256KB flash, 64KB SRAM, 10/100 Ethernet, USB 2.0 Host/Device/OTG, 2 CAN, I <sup>2</sup> S, 12-bit ADC, 10-bit DAC	1718548	15R1839
LPC1768FBD100	NXP	ARM Cortex-M3 microcontroller with 512KB flash, 64KB SRAM, 10/100 Ethernet, USB 2.0 Host/Device/OTG, 2 CAN, I <sup>2</sup> S, 12-bit ADC, 10-bit DAC	1718549	15R1840

### Similar Products:

Part Number	Manufacturer	Description	Support Device	Farnell P/N	Newark P/N
OM11042	NXP	Rapid prototyping for the LPC2368 MCU	LPC2368	1761178	33R0886

## Document List:

### Datasheets:

Part Number	Description	Size
LPC1768	<a href="#">LPC1768 Datasheet</a>	946KB

### Application Notes:

File Name	Size
<a href="#">IEC 60601-1-8 audible alert generator using the LPC1700</a>	649KB
<a href="#">LPC1700 Ethernet MII Management (MDIO) via software</a>	256KB
<a href="#">LPC1700 RTC hardware auto calibration</a>	337KB
<a href="#">LPC1700 secondary USB boot loader</a>	771KB
<a href="#">LPC1700 timer triggered memory to GPIO data transfer</a>	163KB
<a href="#">Migrating to the LPC1700 series</a>	615KB
<a href="#">Porting uIP1.0 to LPC1700</a>	365KB
<a href="#">Using Code Read Protection in LPC1700</a>	241KB

### Hardware & Software:

File Name	Size
<a href="#">Errata sheet LPC1758</a>	42.1KB