

THIS DRAWING IS UNPUBLISHED. RELEASED FOR PUBLICATION
 © COPYRIGHT BY TYCO ELECTRONICS CORPORATION. ALL RIGHTS RESERVED.

LOC	DIST	REVISIONS 変更						
		P	LTR	DESCRIPTION	ECN	DATE	DWN	APVD
			01	RELEASE	FK00-0096-04	07-JUN-04	H.S	A.N
		A		MODIFY VENT HOLE&ADD NOTE	ECO-06-008136	15-FEB-06	JG	HSU

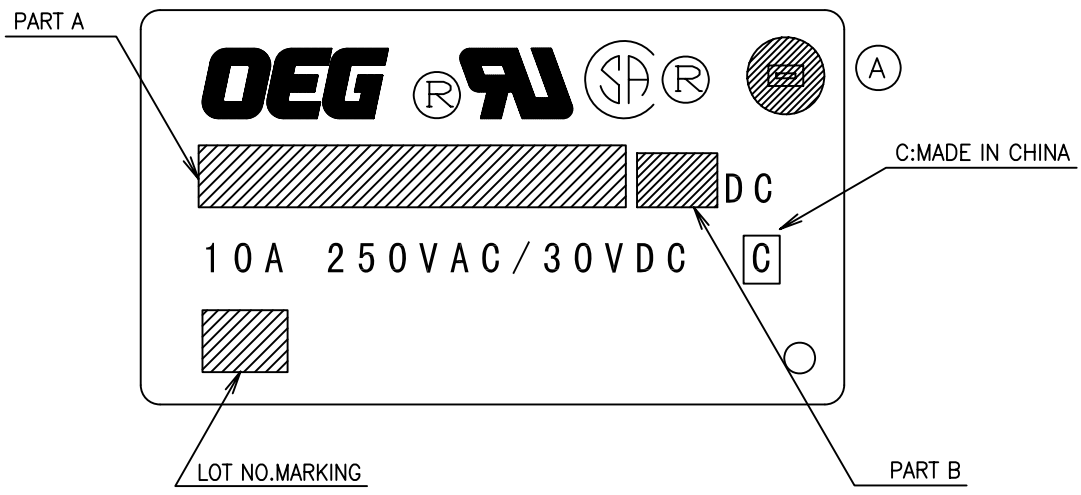

(A) NOTES:
 1.LOT NUMBERING SYSTEM AS FOLLOWS:

 DATE
 MONTH
 YEAR

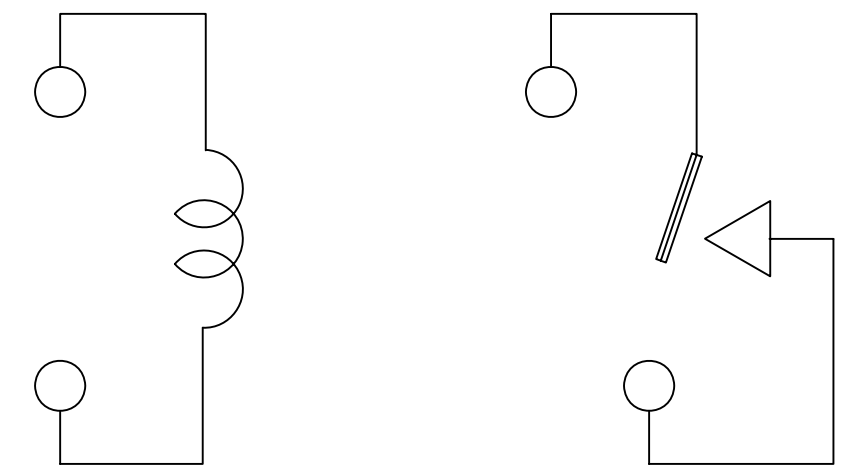

CONNECTION FIGURE

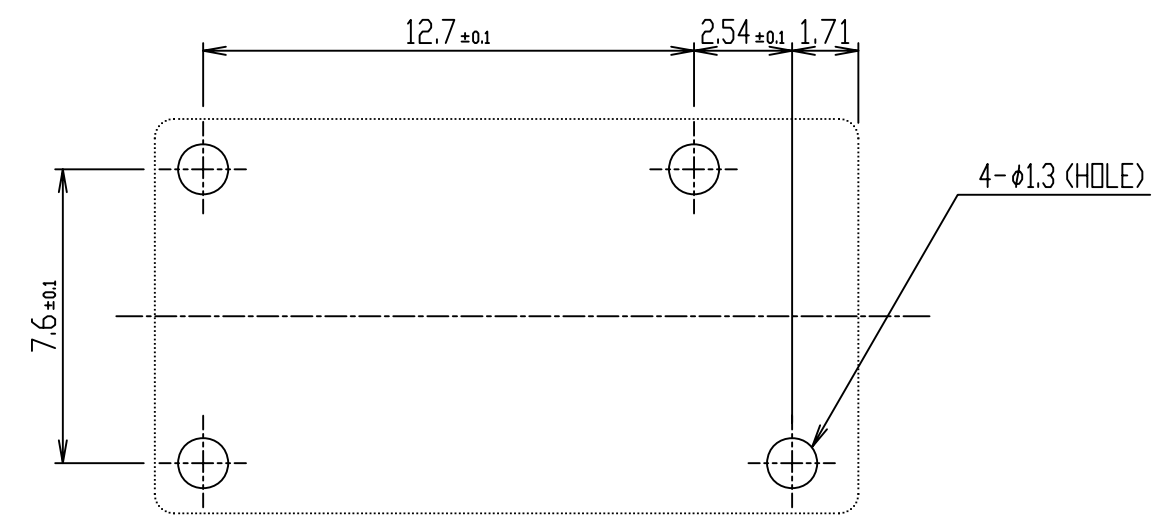
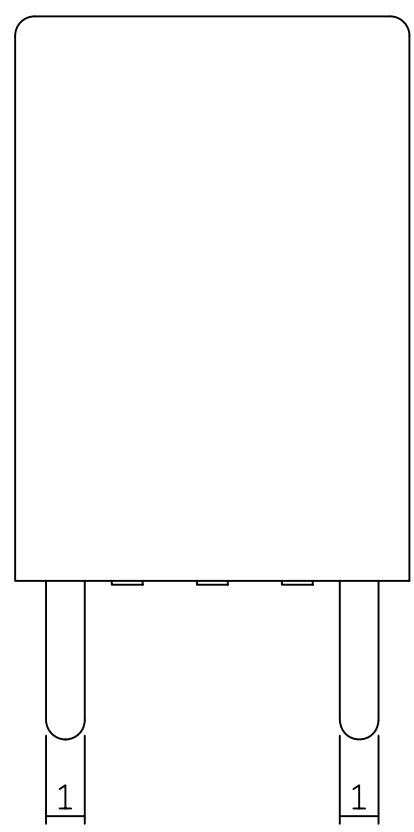
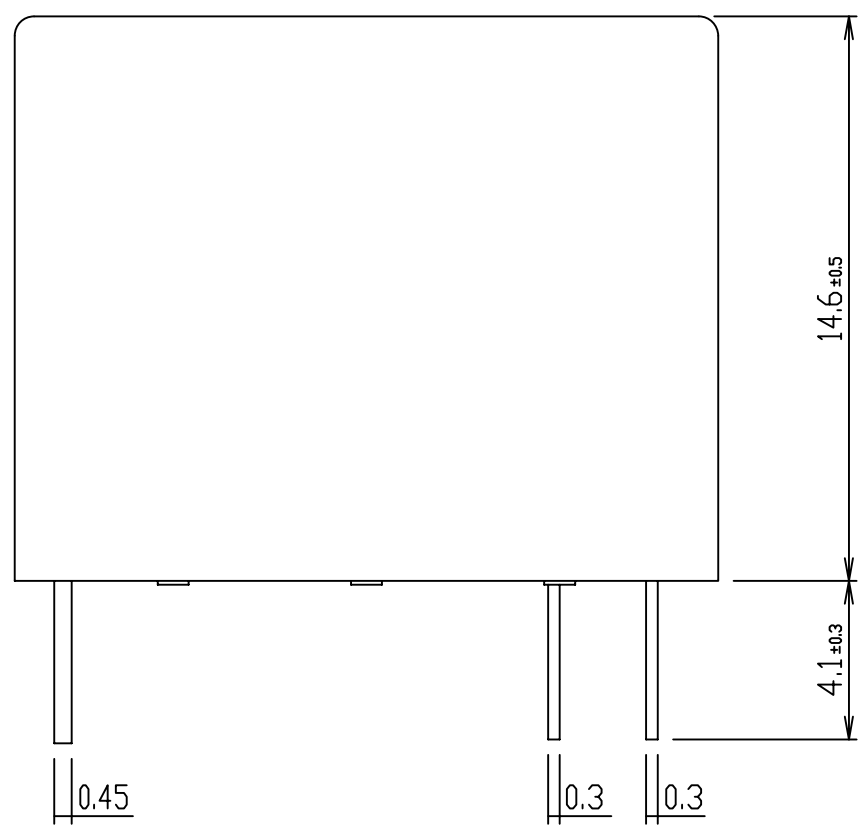
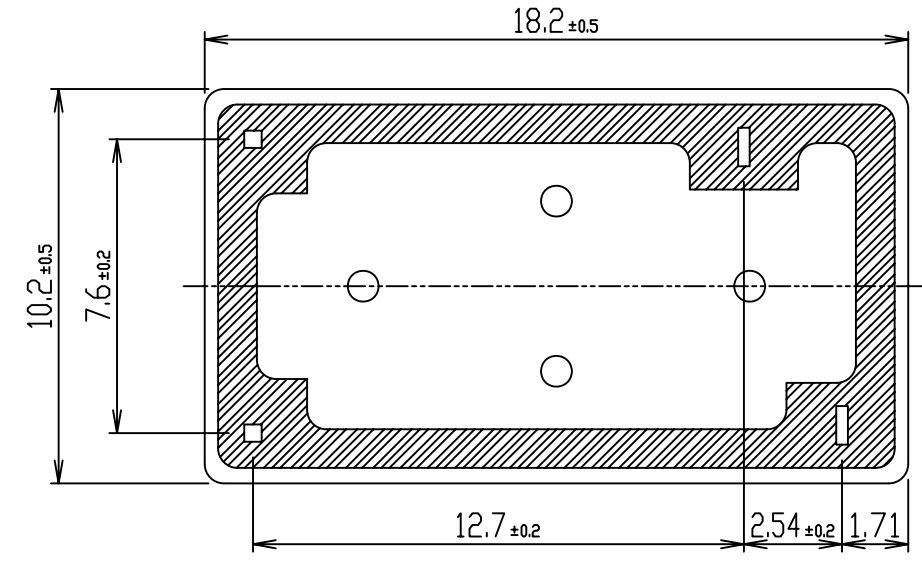

FIGURE FOR PRINTED CIRCUIT BOARD PROCESSING
 (BOTTOM VIEW)



THIS DRAWING IS A CONTROLLED DOCUMENT FOR TYCO ELECTRONICS CORPORATION IT IS SUBJECT TO CHANGE AND THE CONTROLLING ENGINEERING ORGANIZATION SHOULD BE CONTACTED FOR THE LATEST REVISION.		DWN	H.SASAKI		Tyco Electronics EC K.K. Tochigi, Japan		
DIMENSIONS: 单位: 耗 mm		CHK	Y.OIKAWA				
TOLERANCES UNLESS OTHERWISE SPECIFIED:		APVD	A.NAGAI		NAME 名称 OJE-SH-HM SPEC,000		
0 PLC ± 1 PLC ± 2 PLC ± 3 PLC ± 4 PLC ± ANGLES ±		PRODUCT SPEC 製品规格	SEE SPEC TABLE				
MATERIAL 材料		FINISH 仕上	APPLICATION SPEC 取付適用规格	SIZE	CAGE CODE	DRAWING NO 番号	RESTRICTED TO
				A3	00779	G= 1461402	
CUSTOMER DRAWING				SCALE 尺度	5:1	SHEET 1 OF 2	REV A

4 | 3 | 2 | 1

THIS DRAWING IS UNPUBLISHED. | RELEASED FOR PUBLICATION
 © COPYRIGHT | BY TYCO ELECTRONICS CORPORATION. ALL RIGHTS RESERVED.

LOC HH	DIST	REVISIONS 変更						
		P	LTR	DESCRIPTION	ECN	DATE	DWN	APVD

1461402-1	OJE-SH-148HM, 000	SEAL UP INSPECTION ON EVERY PRODUCT	108-79756	48V	OJE-SH-148HM	g
1461402-2	OJE-SH-124HM, 000	SEAL UP INSPECTION ON EVERY PRODUCT	108-79757	24V	OJE-SH-124HM	f
1461402-6	OJE-SH-112HM, 000	SEAL UP INSPECTION ON EVERY PRODUCT	108-79759	12V	OJE-SH-112HM	e
1461402-3	OJE-SH-109HM, 000	SEAL UP INSPECTION ON EVERY PRODUCT	108-79760	9V	OJE-SH-109HM	d
1461402-5	OJE-SH-106HM, 000	SEAL UP INSPECTION ON EVERY PRODUCT	108-79761	6V	OJE-SH-106HM	c
1461402-4	OJE-SH-105HM, 000	SEAL UP INSPECTION ON EVERY PRODUCT	108-79762	5V	OJE-SH-105HM	b
1461402-7	OJE-SH-103HM, 000	SEAL UP INSPECTION ON EVERY PRODUCT	108-79763	3V	OJE-SH-103HM	a
AMP PART NO	EC TYPE NAME	DESCRIPTION	PRODUCT SPEC	PART B	PART A	TYPE

RELAY TYPE

AR	AR	AR	AR	AR	AR	AR	AR			UV RESIN	SEEL (VENT HOLE)	16
AR	AR	AR	AR	AR	AR	AR	AR			EPOXY RESIN	SEEL (BASE & BOBBIN)	15
1	1	1	1	1	1	1	1			3UEW	MAGNETIC WIRE	14
1	1	1	1	1	1	1	1	94V-0		P.B.T	CASE	13
1	1	1	1	1	1	1	1	94V-0		P.B.T	BASE	12
1	1	1	1	1	1	1	1	94V-0		P.B.T	BOBBIN	11
2	2	2	2	2	2	2	2		SOLDER DIP	C.P WIRE	COIL TERMINAL	10
1	1	1	1	1	1	1	1	94V-0		P.P.S	CARD	9
1	1	1	1	1	1	1	1			Ag ALLOY	MOVABLE CONTACT	8
1	1	1	1	1	1	1	1			Ag	NO.CONTACT	7
1	1	1	1	1	1	1	1			STEEL	HINGE SPRING	6
1	1	1	1	1	1	1	1		SOLDER DIP	PBP	NO.TERMINAL	5
1	1	1	1	1	1	1	1		SOLDER DIP	Cu ALLOY	MOVABLE SPRING	4
1	1	1	1	1	1	1	1		NIP	STEEL	CORE	3
1	1	1	1	1	1	1	1		NIP	STEEL	ARMATURE	2
1	1	1	1	1	1	1	1		NIP	STEEL	YOKE	1
g	f	e	d	c	b	a		INCOMBUSTIBILITY	TREATMENT	MATERIAL	DESCRIPTION	ITEM

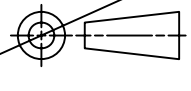
THIS DRAWING IS A CONTROLLED DOCUMENT FOR TYCO ELECTRONICS CORPORATION IT IS SUBJECT TO CHANGE AND THE CONTROLLING ENGINEERING ORGANIZATION SHOULD BE CONTACTED FOR THE LATEST REVISION.		DWN		 Tyco Electronics EC K.K. Tochigi, Japan	
DIMENSIONS: 単位: 耗		CHK			
		APVD		NAME 名称	
TOLERANCES UNLESS OTHERWISE SPECIFIED: 0 PLC ± 1 PLC ± 2 PLC ± 3 PLC ± 4 PLC ± ANGLES ±		PRODUCT SPEC 製品規格		OJE-SH-HM SPEC,000	
MATERIAL 材料		FINISH 仕上		APPLICATION SPEC 取付適用規格	
		WEIGHT		SIZE CAGE CODE DRAWING NO 番号	
		CUSTOMER DRAWING		A3 00779 G= 1461402	
				RESTRICTED TO	
				SCALE 尺度 SHEET 2 OF 2 REV A	