

OA172EC Series

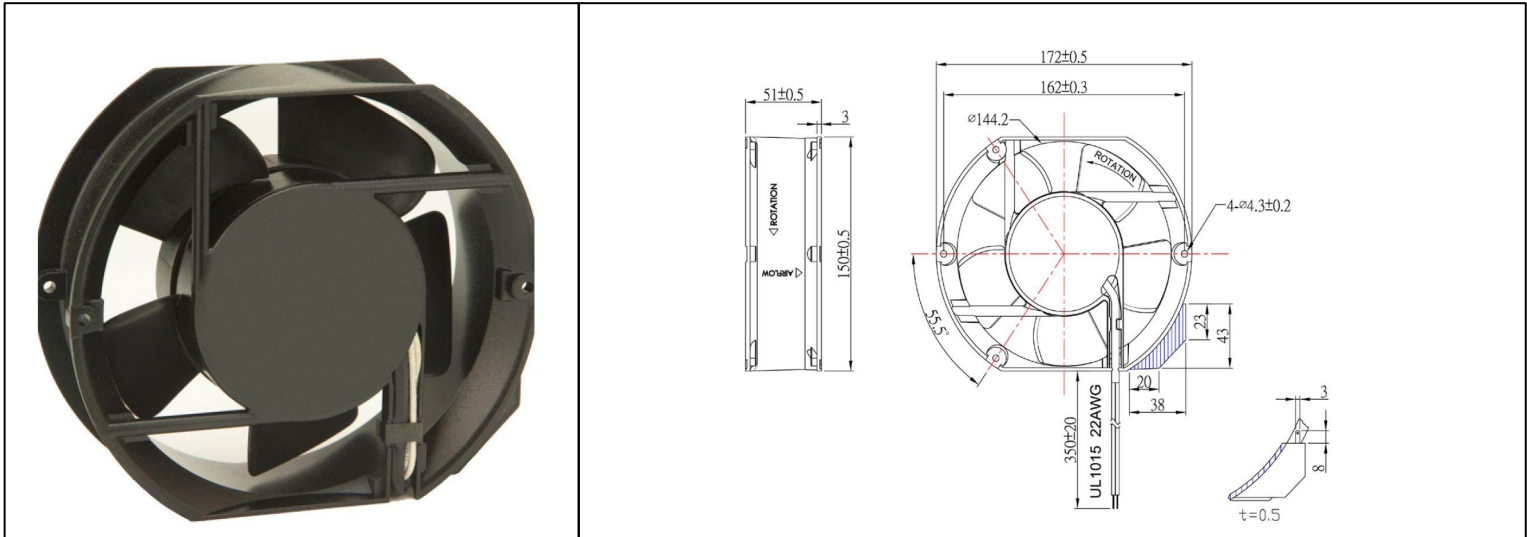

EC Fan -115V, 230V
172x150x51mm (6.7" x 5.9" x 2.0")



Frame	Aluminum (ADC-12)	Operating Temperature -20C ~ +70C Life Expectancy 50,000 hours (L10 at 40C) Weight: ~ 1.54 lbs m2	
Impeller	PBT UL94V0- Plastic		
Connection	Terminal or Wire Leads		
Motor	EC Motor, electronically protected		
Bearing System	Dual Ball Bearings		
Dielectric Strength	1 sec at 1800 VAC, 50/60Hz		

Part Number	OA172EC-11-1*	OA172EC-22-1*
Rated Voltage	115 VAC (50/60Hz)	230 VAC (50/60Hz)
Voltage Range	103 ~ 127 VAC (50/60Hz)	207 ~ 253 VAC (50/60Hz)
Nominal Power	15 W	15 W
Rated Current	0.23A	0.13 A
Rated Speed (RPM)	3000	3000
Airflow (CFM)	220	220
Noise Level (dB)	57	57
Max. Static Pressure	0.62"H ₂ O	0.62"H ₂ O

*Insert T for Terminal and W for Wire Leads



OA172EC Series



EC Fan Universal Voltage
172x152x51.6mm (6.77" x 5.98" x 2.03")

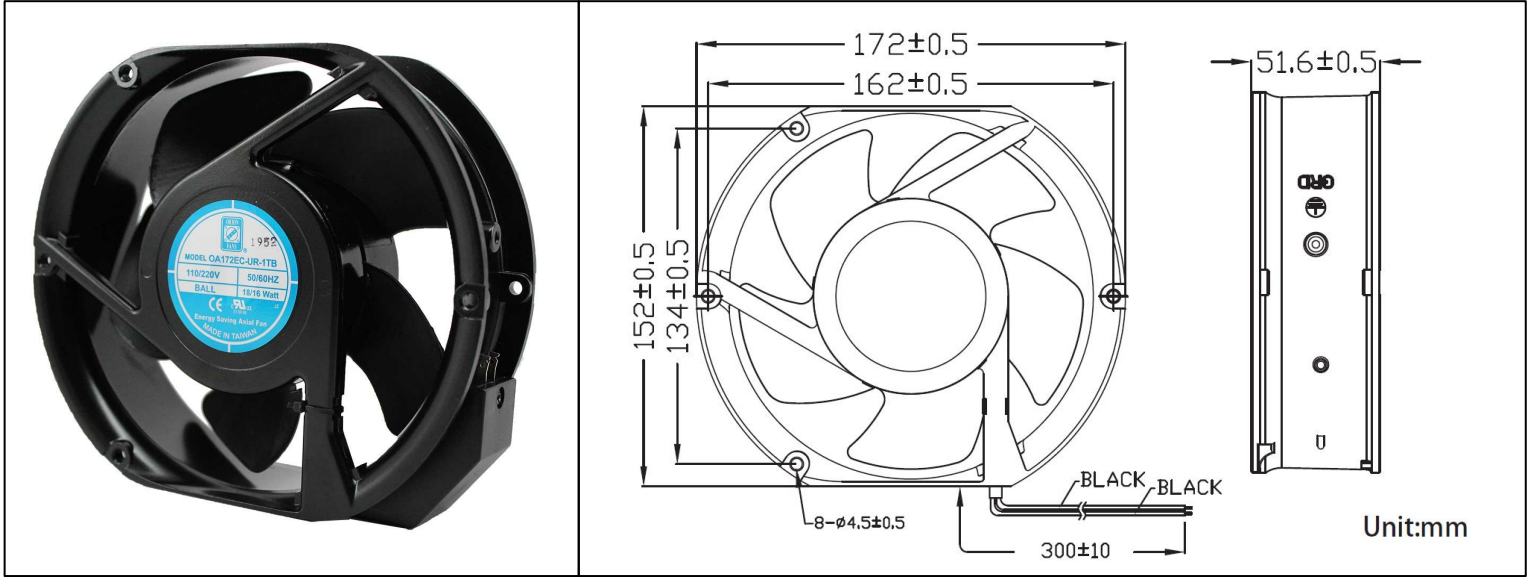

Frame	Black, Aluminum Diecast	<u>Operating Temperature</u> -10C ~ +70C <u>Storage Temperature</u> -40C ~ +75C <u>Life Expectancy</u> 50,000 hours (L10 at 40C) Weight: ~ 1.47 lbs m0	
Impeller	PBT UL94V0- Plastic		
Connection	Terminal or Wire Leads		
Motor	AC-DC Energy Saving, Electronically Protected		
Bearing System	Dual Ball Bearings		
Dielectric Strength	1400VAC/min		

Part Number	OA172EC-UR-1*B
Rated Voltage	110/220 VAC
Voltage Range	90 ~ 265
Rated Input	18 ~ 16 (12.5)W
Rated Speed (RPM)	3000
Airflow (CFM)	220
Noise Level (dB)	55
Max. Static Pressure	0.8"H ₂ O

*Insert T for Terminal and W for Wire Leads