

THIS DOCUMENT IS SUBJECT TO CHANGE WITHOUT NOTICE. IT IS CONFIDENTIAL AND A PROPERTY OF AMPHENOL LTW. DISCLOSURE TO THIRD PARTY HAS TO BE AUTHORIZED BY AMPHENOL LTW.

REV.	DESCRIPTION
B	Update Description

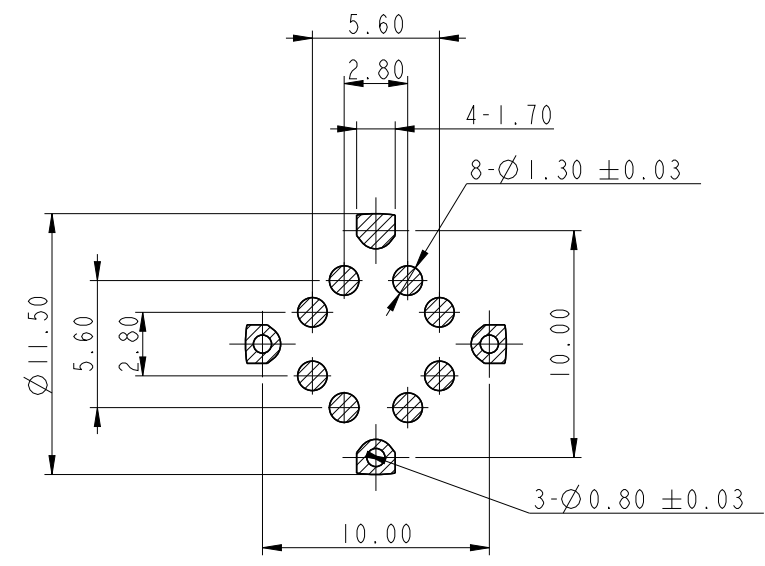

Recommended PCB Layout  
General tolerance: ±0.05mm

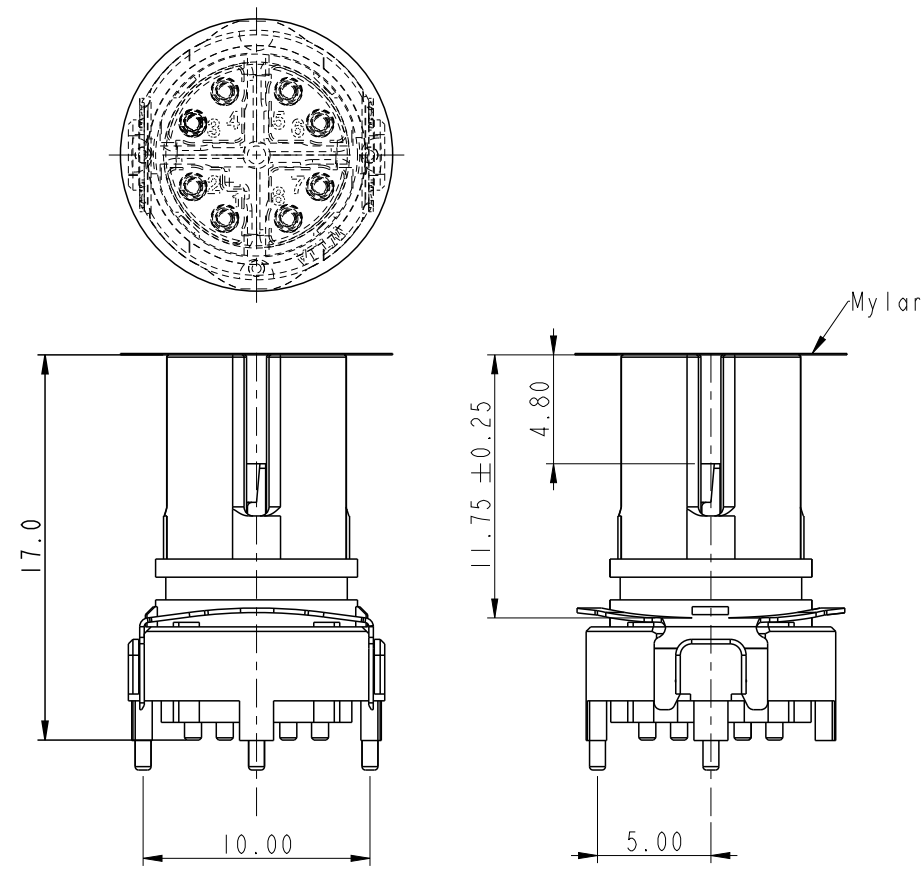
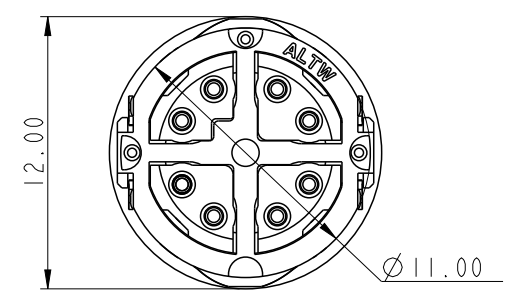

- Note:
- \* Waterproof Rate: IP67 (Mated Condition)
  - \* Connector: Thermoplastic, Black
  - \* Female Pin: Copper Alloy, Gold Plated
  - \* Shield & Spring: Metal
  - \* Withstand voltage test 2.2KVdc between shield and pin, 500Vac between adjacent pin
  - \* Coplanarity of all contacts: 0.10mm maximum.

UNIT: mm TOLERANCE .X ±0.25 .XX ±0.1 .XXX ±0.05 ANGLES ±1°	TITLE M12 X-Code, Panel Ended SMT Type		<h1 style="text-align: center;">Amphenol LTW</h1> <h2 style="text-align: center;">安費諾亮泰企業股份有限公司</h2>		ITEM NO MSXS-08PFFT-EE0001	DRAWN BY Sam Ho	DATE 2018-12-19
	SCALE 3:1	SIZE A4			SHEET 1 OF 3	DWG NO MSXS-08PFFT-EE0001	CHECKED BY Fred Lee
	REV. B	WC-REV. A.16	(QC): Inspection item	CUSTOMER ALTW	APPROVED BY Fred Lee	DATE 2018-12-19	

REV.	DESCRIPTION
B	Update Description

THIS DOCUMENT IS SUBJECT TO CHANGE WITHOUT NOTICE. IT IS CONFIDENTIAL AND A PROPERTY OF Amphenol LTW. DISCLOSURE TO THIRD PARTY HAS TO BE AUTHORIZED BY Amphenol LTW.

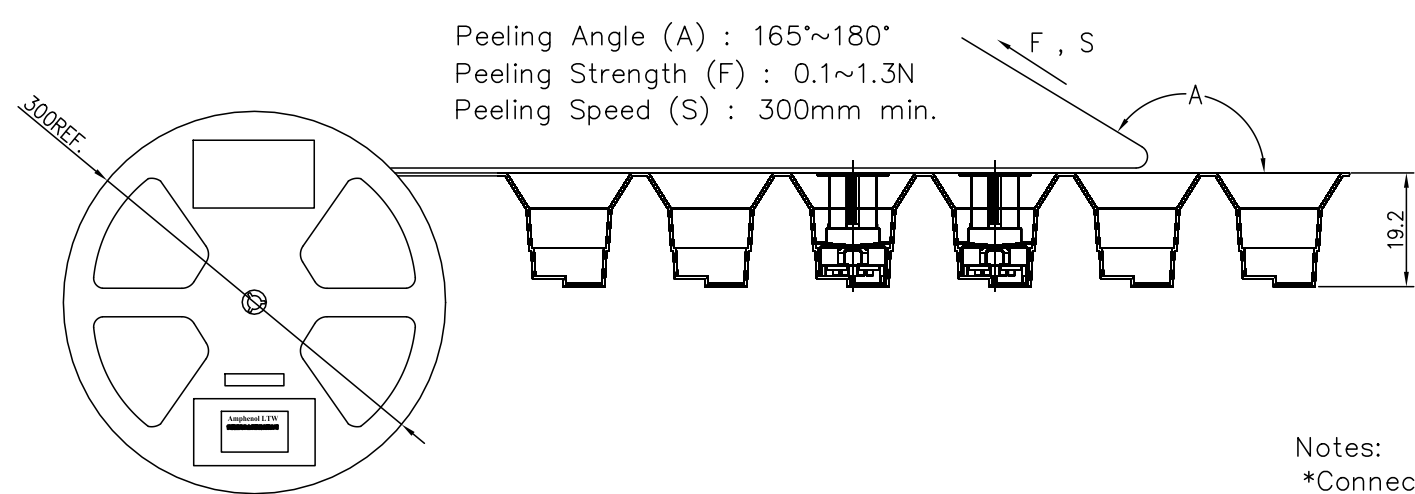
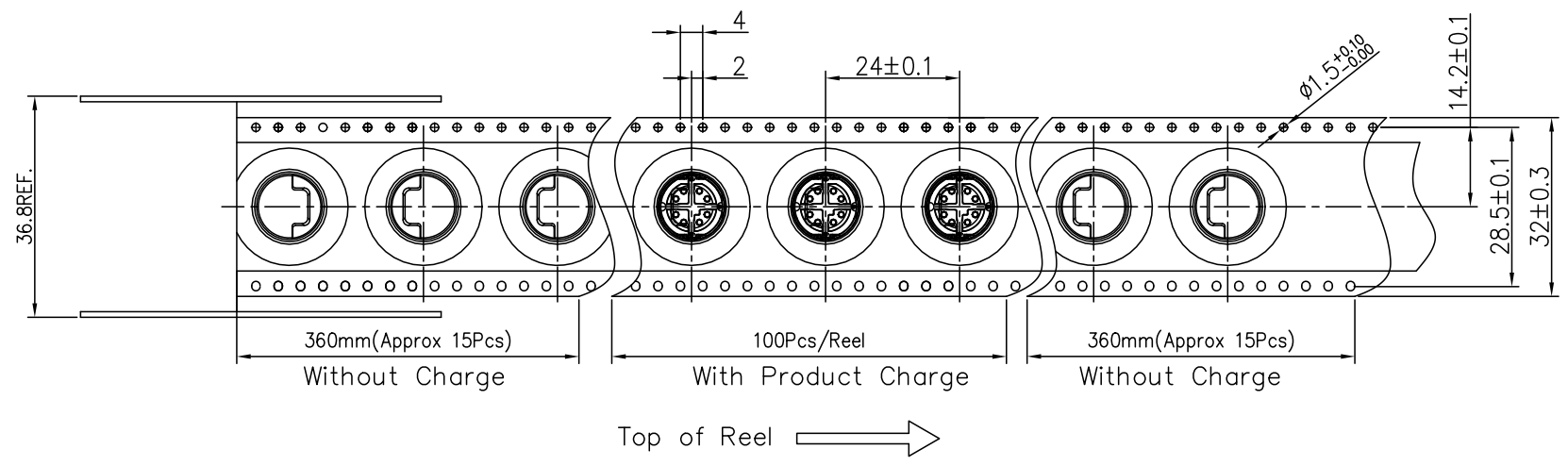

Notes:  
\*Connector Orientation Follow Drawing

A	UNIT: mm		TITLE M12 X-Code Panel Package		 安費諾亮泰企業股份有限公司	ITEM NO MSXS-08PFFT-EE0001	DRAWN BY Sam Ho	DATE 2018-12-19
	TOLERANCE ±0.5mm		SCALE Free	SHEET 2 OF 3		DWG NO MSXS-08PFFT-EE0001	CHECKED BY Fred Lee	DATE 2018-12-19
	REV. B	SIZE A4	©: Inspection Item		CUSTOMER ALTW	APPROVED BY Fred Lee	DATE 2018-12-19	8 W0814-03-表單01A1

REV.	DESCRIPTION
B	Update Description

THIS DOCUMENT IS SUBJECT TO CHANGE WITHOUT NOTICE. IT IS CONFIDENTIAL AND A PROPERTY OF Amphenol LTW. DISCLOSURE TO THIRD PARTY HAS TO BE AUTHORIZED BY Amphenol LTW.

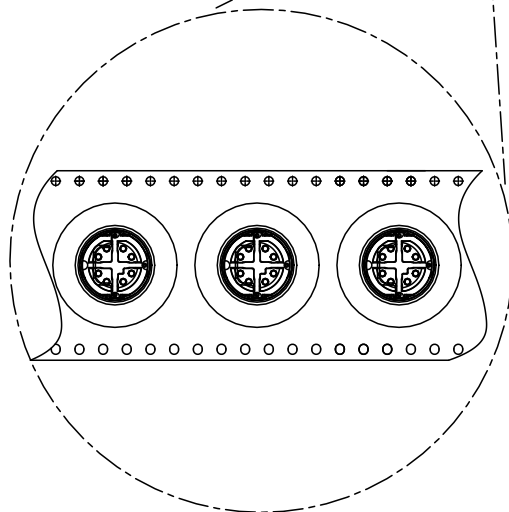
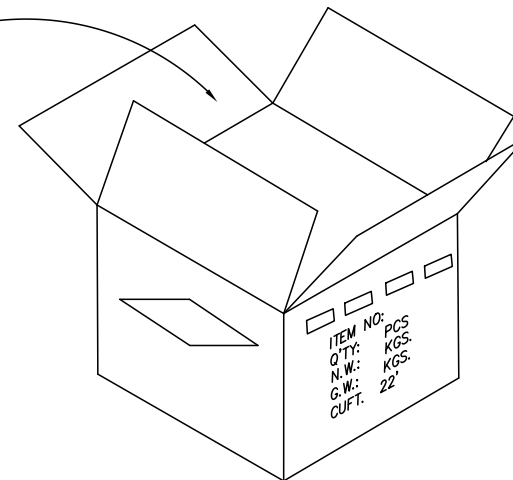
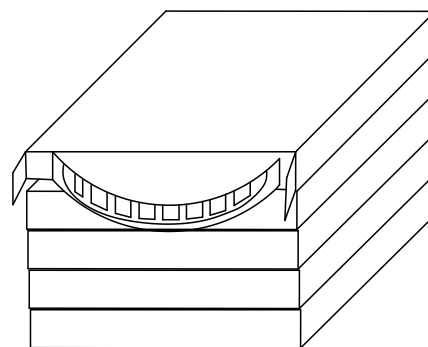
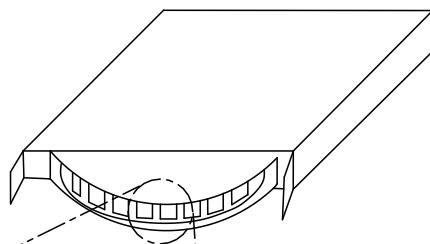
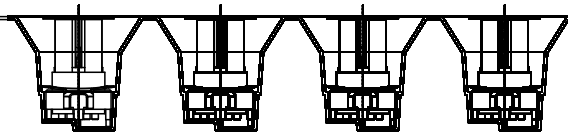
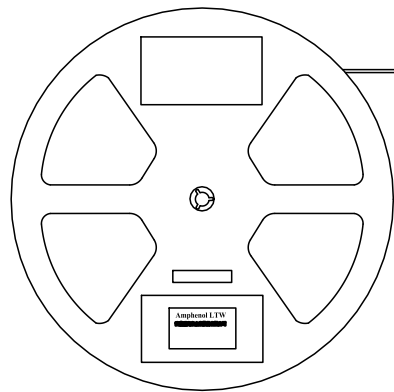

Notes:

\*Tape&Reel(Box) Quantity : 100pcs/Reel(Box).

\*Carton Quantity : 500pcs/Carton.

A	UNIT: mm		TITLE	<b>Amphenol LTW</b> 安費諾亮泰企業股份有限公司	ITEM NO	DRAWN BY	DATE
	TOLERANCE		M12 X-Code Panel Package		MSXS-08PFFT-EE0001	Sam Ho	2018-12-19
	±0.5mm		SCALE		DWG NO	CHECKED BY	DATE
			Free		MSXS-08PFFT-EE0001	Fred Lee	2018-12-19
			SHEET		CUSTOMER	APPROVED BY	DATE
			3 OF 3		ALTW	Fred Lee	2018-12-19
			REV. B	SIZE A4			
				QC: Inspection Item			