

Non Isolated Board Mount DC / DC Converters

multicomp PRO

Wide input voltage non-isolated and regulated single output

**RoHS
Compliant**



Description

MP-K78xx-1000R3 series are high efficiency switching regulators and ideal substitutes for LM78xx series three-terminal linear regulators. The converters feature high efficiency, low loss, short circuit protection, positive or negative output voltage, and there is no need for a heat sink. These product are widely used in applications such as industrial control, instrumentation and electric power.



Features

- High efficiency up to 96%
- No-load input current as low as 0.1mA
- Operating ambient temperature range -40°C to +85°C
- Support the negative output
- Output short-circuit protection
- Pin compatible with LM78xx series

Selection Guide					
Part Number	Input Voltage (VDC)*	Output		Full Load Efficiency (%) Vin Min. / Vin Max.	Capacitive Load (µF) Max.
	Nominal (Range)	Voltage (VDC)	Current (mA) Max.		
MP-K7803-1000R3	24 (6-36)	3.3	1000	90/81	680
MP-K7805-1000R3	24 (8-36)	5		93/86	
	MP-K7809-1000R3	12 (8-27)	-5	-500	86/82
MP-K7812-1000R3		24 (13-36)	9	1000	95/90
	24 (16-36)	12	96/93		
MP-K7815-1000R3	12 (8-20)	-12	-300	89/88	330
	24 (20-36)	15	1000	96/94	680
	12 (8-18)	-15	-300	89/89	330

Note:
1 For input voltage exceeding 30 VDC, an input capacitor of 22µF/50V is required.

Input Specifications					
Item	Operating Conditions	Min.	Typ.	Max.	Unit
No-load Input Current	Positive output	--	0.1	1	mA
Input Filter		Capacitance filter			

Newark.com/multicomp-pro
Farnell.com/multicomp-pro
Element14.com/multicomp-pro

multicomp PRO

Non Isolated Board Mount DC / DC Converters

multicomp PRO

Output Specifications						
Item	Operating Conditions		Min.	Typ.	Max.	Unit
Voltage Accuracy	Full load, input voltage range	MP-K7803-1000R3	--	±2	±4	%
		Others	--		±3	
Linear Regulation	Full load, input voltage range		--	±0.2	±0.4	
Load Regulation	Nominal input , 10% -100% load		--	±0.4	±0.6	
Ripple & Noise*	20MHz bandwidth, nominal input, 20% -100% load		--	20	75	mVp-p
Temperature Coefficient	Operating temperature -40°C to +85°C		--	--	±0.03	%/°C
Transient Response Deviation	Nominal input, 25% load step change		--	50	300	mV
Transient Recovery Time			--	0.1	1	ms
Short-circuit Protection	Nominal input		Continuous, self-recovery			

Notes: * 1. The "parallel cable" method is used for Ripple and noise test, please refer to DC-DC Converter Application Notes for specific information;
2. With light loads at or below 20%, Ripple & Noise for 3.3/5V output parts increases to 100mVp-p max, and for 9V/12V/15V output parts to 2%Vo max.

General Specifications						
Item	Operating Conditions		Min.	Typ.	Max.	Unit
Operating Temperature*	Derating if the temperature ≥71°C (see Fig. 1)		-40	--	85	°C
Storage Temperature			-55	--	125	
Pin Soldering Resistance Temperature	Soldering time: 10 seconds		--	--	260	
Storage Humidity	Non-condensing		5	--	95	%RH
Switching Frequency	Full load, nominal input	MP-K7803-1000R3/ MP-K7805-1000R3	420	520	620	KHz
		Other output	580	680	780	
MTBF	MIL-HDBK-217F@25°C		2000	--	--	K hours

Mechanical Specifications		
Case Material	Black plastic; flame-retardant and heat-resistant (UL94 V-0)	
Dimensions	MP-K78xx-1000R3	11.5mm × 9mm × 17.5mm
Weight	3.8g (Typ.)	
Cooling Method	Free air convection	

Electromagnetic Compatibility (EMC)				
Emissions	CE	CISPR32/EN55032	CLASS B (see Fig. 4-2 for recommended circuit)	
	RE	CISPR32/EN55032	CLASS B (see Fig. 4-2 for recommended circuit)	
Immunity	ESD	IEC/EN 61000-4-2	Contact ±4KV	perf. Criteria B
	RS	IEC/EN 61000-4-3	10V/m	perf. Criteria A
	EFT	IEC/EN 61000-4-4	±1KV (see Fig. 4-1 for recommended circuit)	perf. Criteria B
	Surge	IEC/EN 61000-4-5	line to line ±1KV(see Fig. 4-1 for recommended circuit)	perf. Criteria B
	CS	IEC/EN 61000-4-6	3Vr.m.s	perf. Criteria A

Newark.com/multicomp-pro
Farnell.com/multicomp-pro
Element14.com/multicomp-pro

multicomp PRO

Non Isolated Board Mount DC / DC Converters

Typical Characteristic Curves

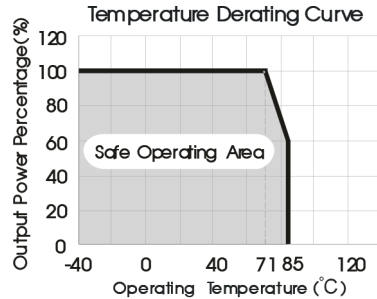
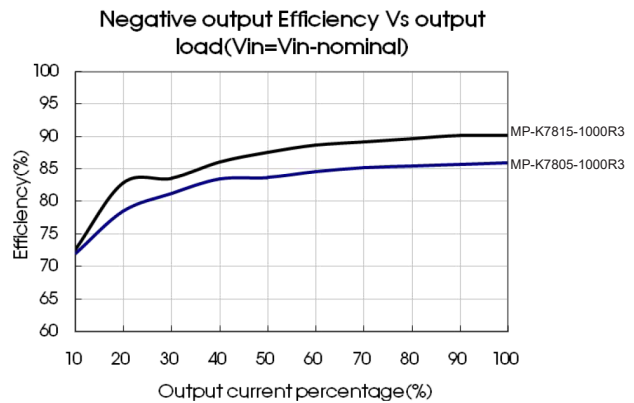
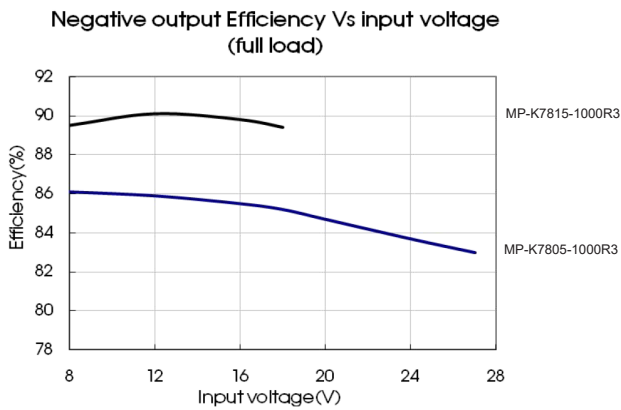
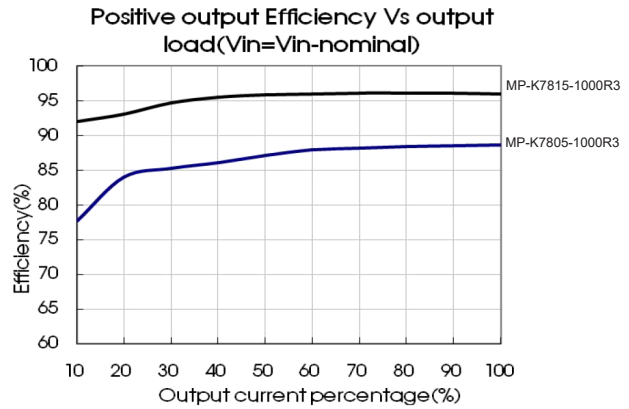
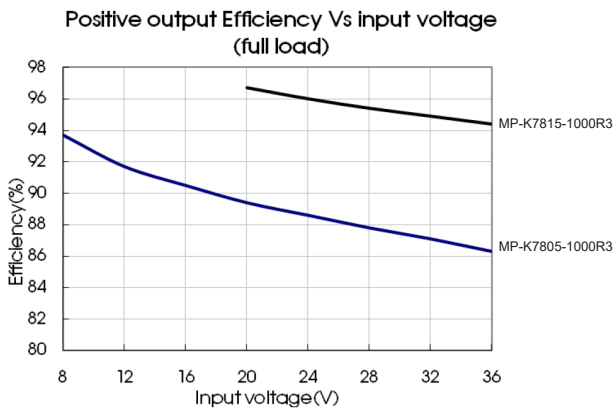

Fig. 1



Non Isolated Board Mount DC / DC Converters

Design Reference

1. Typical application

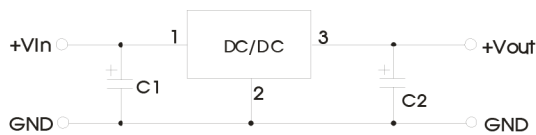

Positive output application circuit

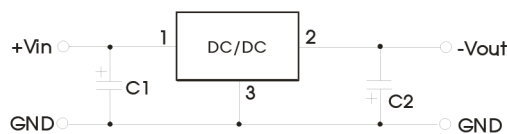

Negative output application circuit

Fig. 2 Typical application circuit

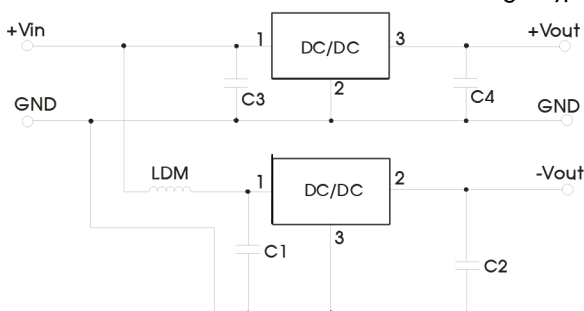

Fig. 3 Positive and Negative output application circuit

Table 1

Part Number	C1/C3 (ceramic capacitor)	C2/C4 (ceramic capacitor)
MP-K7803-1000R3	10μF/50V	22μF/10V
MP-K7805-1000R3		22μF/16V
MP-K7809-1000R3		22μF/25V
MP-K7812-1000R3		
MP-K7815-1000R3		

Note:

1. The required capacitors C1 and C2 (C3 and C4) must be connected as close as possible to the terminals of the module;
2. Refer to Table 1 for C1 and C2 (C3 and C4) capacitor values. For certain applications, increased values for C2 and C4 and/ or tantalum or low ESR electrolytic capacitors may also be used instead;
3. When using configurations as shown in figure 3, we recommended to add an inductor (LDM) with a value of up to 10μH which helps reducing mutual interference;
4. Converter cannot be used for hot swap and with output in parallel.

2. EMC compliance circuit

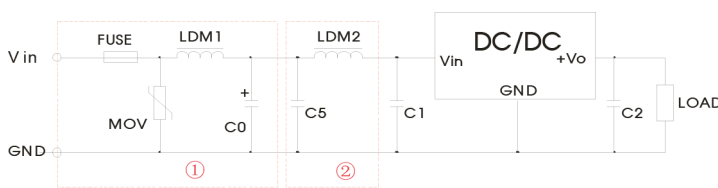

Fig. 4 EMC recommended circuit

FUSE	MOV	LDM1	C0	C1/C2	C5	LDM2
Select fuse value according to actual input current	S20K30	82μH	680μF /50V	Refer to table 1	4.7μF /50V	12μH

Note: Part 1 in Fig. 4 shows EMS compliance filter and part 2 filter for EMI compliance; depending on requirement both filters 1 and 2 can be used in series as shown.

Non Isolated Board Mount DC / DC Converters

multicomp PRO

Dimensions and Recommended Layout

MP-K78xx-1000R3

THIRD ANGLE PROJECTION 

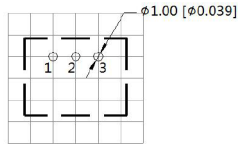
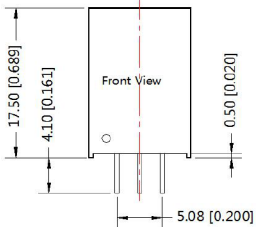

Note : Grid 2.54*2.54mm

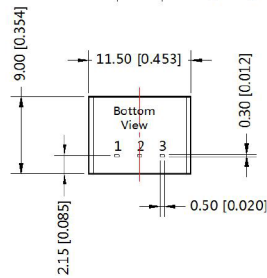

Pin-Out		
Pin	+Output	-Output
1	Vin	Vin
2	GND	-Vo
3	+Vo	GND

Note:
Unit :mm[inch]
Pin diameter tolerances :±0.10[±0.004]
General tolerances:±0.25[±0.010]

Important Notice : This data sheet and its contents (the "Information") belong to the members of the AVNET group of companies (the "Group") or are licensed to it. No licence is granted for the use of it other than for information purposes in connection with the products to which it relates. No licence of any intellectual property rights is granted. The Information is subject to change without notice and replaces all data sheets previously supplied. The Information supplied is believed to be accurate but the Group assumes no responsibility for its accuracy or completeness, any error in or omission from it or for any use made of it. Users of this data sheet should check for themselves the Information and the suitability of the products for their purpose and not make any assumptions based on information included or omitted. Liability for loss or damage resulting from any reliance on the Information or use of it (including liability resulting from negligence or where the Group was aware of the possibility of such loss or damage arising) is excluded. This will not operate to limit or restrict the Group's liability for death or personal injury resulting from its negligence. Multicomp Pro is the registered trademark of Premier Farnell Limited 2019.

Newark.com/multicomp-pro
Farnell.com/multicomp-pro
Element14.com/multicomp-pro

multicomp PRO