

# Signal conditioner - MINI MCR-2-UI-UI - 2902037

Please be informed that the data shown in this PDF Document is generated from our Online Catalog. Please find the complete data in the user's documentation. Our General Terms of Use for Downloads are valid (<http://phoenixcontact.com/download>)



3-way signal conditioner with plug-in connection technology and calibrated measuring range changeover for the electrical isolation of unipolar and bipolar analog signals. Input/output configurable via DIP switch. Screw connection technology, standard configuration.

Figure shows MINI MCR-2-UI-UI-PT version

## Product Description

The 3-way signal conditioner with plug-in connection technology and calibrated measuring range changeover can be configured using DIP switches and is used for the electrical isolation, conversion, amplification, and filtering of unipolar and bipolar standard and normalized signals. On the input side, the standard analog signals 0 ... 20 mA, 4 ... 20 mA, 0 ... 10 V, 0 ... 5 V, 1 ... 5 V or -10 ... 10 V, and signals 2 ... 10 V, 0 ... 20 V, 4 ... 20 V, 0 ... 24 V, 0 ... 30 V, -5 ... 5 V, -20 ... 20 V, -24 ... 24 V, -30 ... 30 V and -20 ... 20 mA are available. On the output side, 0 ... 20 mA, 4 ... 20 mA, 0 ... 10 V, 0 ... 5 V, 1 ... 5 V, -10 ... 10 V and -5 ... 5 V are possible. There is no need for adjustment following a measuring range changeover. The measuring transducer supports fault monitoring and NFC communication.



## Key Commercial Data

Packing unit	1 STK
GTIN	 4 046356 649728

## Technical data

### Note

Utilization restriction	EMC: class A product, see manufacturer's declaration in the download area
-------------------------	---

### Dimensions

Width	6.2 mm
Height	110.5 mm
Depth	120.5 mm

### Ambient conditions

Ambient temperature (operation)	-40 °C ... 70 °C
Ambient temperature (storage/transport)	-40 °C ... 85 °C
Degree of protection	IP20

## Signal conditioner - MINI MCR-2-UI-UI - 2902037

### Technical data

#### Input data

Number of inputs	1
Configurable/programmable	Yes
Voltage input signal	0 V ... 5 V (via DIP switch)
	1 V ... 5 V (via DIP switch)
	-5 V ... 5 V (via DIP switch)
	0 V ... 10 V (via DIP switch)
	2 V ... 10 V (via DIP switch)
	-10 V ... 10 V (via DIP switch)
	0 V ... 20 V (via DIP switch)
	4 V ... 20 V (via DIP switch)
	-20 V ... 20 V (via DIP switch)
	0 V ... 24 V (via DIP switch)
	4.8 V ... 24 V (via DIP switch)
	-24 V ... 24 V (via DIP switch)
	0 V ... 30 V (via DIP switch)
	6 V ... 30 V (via DIP switch)
	-30 V ... 30 V (via DIP switch)
Current input signal	0 mA ... 20 mA (via DIP switch)
	4 mA ... 20 mA (via DIP switch)
	-20 mA ... 20 mA (via DIP switch)
Max. input voltage	33 V
Max. input current	24 mA
Input resistance of voltage input	> 1000 k $\Omega$
Input resistance current input	approx. 63 $\Omega$

#### Output data

Number of outputs	1
Configurable/programmable	Yes
Voltage output signal	0 V ... 5 V (via DIP switch)
	1 V ... 5 V (via DIP switch)
	-5 V ... 5 V (via DIP switch)
	0 V ... 10 V (via DIP switch)
	2 V ... 10 V (via DIP switch)
	-10 V ... 10 V (via DIP switch)
Current output signal	0 mA ... 20 mA (via DIP switch)
	4 mA ... 20 mA (via DIP switch)
Max. output current	22 mA
Short-circuit current	< 32 mA
Load/output load voltage output	$\geq$ 10 k $\Omega$
Load/output load current output	$\leq$ 600 $\Omega$ (at 20 mA)

#### Power supply

# Signal conditioner - MINI MCR-2-UI-UI - 2902037

## Technical data

### Power supply

Nominal supply voltage	24 V DC
Supply voltage range	9.6 V DC ... 30 V DC (The DIN rail bus connector (ME 6,2 TBUS-2 1,5/5-ST-3,81 GN, Order No. 2869728) can be used to bridge the supply voltage. It can be snapped onto a 35 mm DIN rail according to EN 60715))
Typical current consumption	25 mA (Current output, at 24 V DC incl. load)
	54 mA (Current output, at 12 V DC incl. load)
Power consumption	≤ 800 mW (at I <sub>OUT</sub> = 20 mA, 9.6 V DC, 600 Ω load)

### Connection data

Connection method	Screw connection
Single conductor/terminal point, solid, with ferrule, min.	0.2 mm <sup>2</sup>
Single conductor/terminal point, solid, with ferrule, max.	1.5 mm <sup>2</sup>
Single conductor/terminal point, solid, without ferrule, min.	0.2 mm <sup>2</sup>
Single conductor/terminal point, solid, without ferrule, max.	2.5 mm <sup>2</sup>
Conductor cross section flexible min.	0.2 mm <sup>2</sup>
Conductor cross section flexible max.	1.5 mm <sup>2</sup>
Min. AWG conductor cross section, flexible	24
Max. AWG conductor cross section, flexible	12
Stripping length	10 mm
Screw thread	M3

### General

No. of channels	1
Maximum transmission error	≤ 0.1 % (of final value)
	≤ 0.15 % (of final value, at IN: 4 ... 20 mA / OUT: -10 V ... 10 V)
Maximum temperature coefficient	0.01 %/K
Temperature coefficient, typical	0.01 %/K
Limit frequency (3 dB)	30 Hz (via DIP switch)
	5 kHz (via DIP switch)
Step response (10-90%)	< 8.5 ms (with 30 Hz filter)
Protective circuit	Transient protection
Electrical isolation	Reinforced insulation in accordance with IEC 61010-1
Overvoltage category	II
Degree of pollution	2
Rated insulation voltage	300 V (effective)
Test voltage, input/output/supply	3 kV (50 Hz, 1 min.)
Electromagnetic compatibility	Conformance with EMC Directive 2004/108/EC (valid until 19.04.2016) / 2014/30/EU (valid from 20.04.2016)
Noise emission	EN 61000-6-4
Noise immunity	EN 61000-6-2 When being exposed to interference, there may be minimal deviations.
Color	gray

# Signal conditioner - MINI MCR-2-UI-UI - 2902037

## Technical data

### General

Housing material	PBT
Mounting position	any
Assembly instructions	The T connector can be used to bridge the supply voltage. It can be snapped onto a 35 mm DIN rail according to EN 60715.
Conformance	CE-compliant
ATEX	# II 3 G Ex nA IIC T4 Gc X
UL, USA / Canada	UL 508 Listed
	Class I, Div. 2, Groups A, B, C, D T6
	Class I, Zone 2, Group IIC T6
Certificate of classification	DNV GL 14445-15HH

### EMC data

Designation	Electromagnetic RF field
Standards/regulations	EN 61000-4-3
Designation	Fast transients (burst)
Standards/regulations	EN 61000-4-4
Designation	Conducted interferences
Standards/regulations	EN 61000-4-6

### Standards and Regulations

Electromagnetic compatibility	Conformance with EMC Directive 2004/108/EC (valid until 19.04.2016) / 2014/30/EU (valid from 20.04.2016)
Noise emission	EN 61000-6-4
Designation	Electromagnetic RF field
Standards/regulations	EN 61000-4-3
	EN 61000-4-4
Designation	Conducted interferences
Standards/regulations	EN 61000-4-6
Electrical isolation	Reinforced insulation in accordance with IEC 61010-1
Conformance	CE-compliant
ATEX	# II 3 G Ex nA IIC T4 Gc X
UL, USA / Canada	UL 508 Listed
	Class I, Div. 2, Groups A, B, C, D T6
	Class I, Zone 2, Group IIC T6

## Classifications

### eCl@ss

eCl@ss 4.0	27040702
eCl@ss 4.1	27040702
eCl@ss 5.0	27242213
eCl@ss 5.1	27049002

# Signal conditioner - MINI MCR-2-UI-UI - 2902037

## Classifications

### eCl@ss

eCl@ss 6.0	27049002
eCl@ss 7.0	27049002
eCl@ss 8.0	27210120

### ETIM

ETIM 3.0	EC001039
ETIM 4.0	EC002540
ETIM 5.0	EC002653

### UNSPSC

UNSPSC 6.01	30211502
UNSPSC 7.0901	39121004
UNSPSC 11	39121004
UNSPSC 12.01	39121004
UNSPSC 13.2	39121004

## Approvals

### Approvals

---

#### Approvals

UL Listed / cUL Listed / GL / cULus Listed

---

#### Ex Approvals

ATEX / UL Listed / cUL Listed / cULus Listed

---

#### Approvals submitted

---

### Approval details

UL Listed
-----------

cUL Listed
------------

GL
----

# Signal conditioner - MINI MCR-2-UI-UI - 2902037

## Approvals

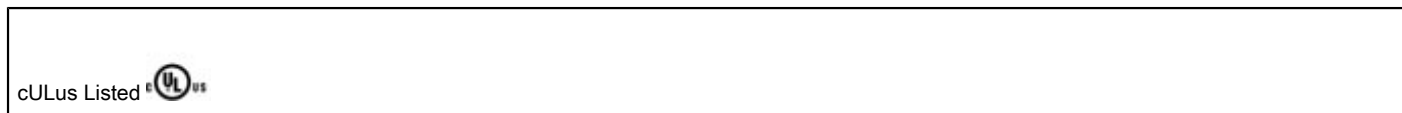

## Drawings

Pictogram



Block diagram

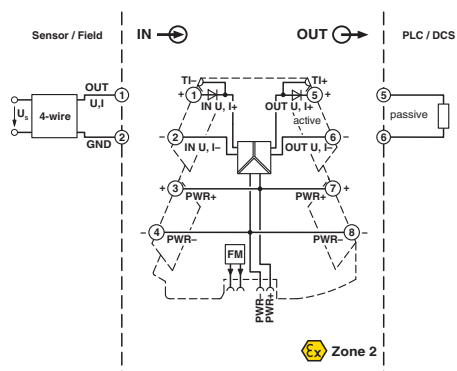

Pictogram

