

# Axial Aluminium Electrolytic Capacitors **multicomp** PRO

**RoHS  
Compliant**



## Allowable Ripple Current Vs Ambient Temperature

Ambient temp (°C)	Under 50	70	85	105
Multiplier	1.95	1.78	1.4	1

## Frequency Coefficient of Allowable Ripple Current

Freq. (Hz) \ Cap. (µF)	60	120	500	1k	10k up
Under 100	0.7	1	1.3	1.4	1.5
100 to 1000	0.75	1	1.2	1.3	1.35
1000 up above	0.8	1	1.1	1.12	1.15

Item	Characteristic										
Operating Temperature Range	-40°C to +105°C										
Capacitance Tolerance	±20% (at 20°C, 120 Hz)										
Leakage Current	I = 0.02CV or 3µA whichever is greater (after 2 minutes applying the rated DC working voltage at 20°C) where: C = rated capacitance in µF V = rated DC working voltage in V										
Dissipation Factor (Tan δ) (At 20°C, 120 Hz)	Rated Voltage (V)	6.3	10	16	25	35	50	63	100		
	Tan δ	0.23	0.2	0.17	0.15	0.12	0.1	0.09	0.08		
For capacitors whose capacitance exceeds 1,000pF, the specification of Tan is increased by 0.02 for every addition of 1,000pF.											
Surge Voltage	Rated Voltage (V)	6.3	10	16	25	35	50	63	100		
	Surge Voltage (V)	7.3	13	20	32	44	63	79	125		
Low Temperature Characteristics	Impedance ratio at 120 Hz.										
	Rated Voltage (V)	6.3	10	16	25	35	50	63	100		
	Z (-25°C)	0D < 16	6	4	3	3	2	2	2	2	
	Z (+20°C)	0D ≥ 16	8	6	4	4	3	3	3	3	
Z (-40°C)	0D < 16	10	8	6	6	4	3	3	3		
	Z (+20°C)	0D ≥ 16	18	16	12	10	8	8	6	6	
Load Life	After 1000 hours application of rated voltage at 85°C, capacitors meet the characteristics requirements listed at right.				Leakage Current		Initial specified value or less				
					Dissipation Factor		Less than 200% of specified value.				
					Capacitance Change		Within ±20% or less of initial value				
Shelf Life	After leaving capacitors under no load at 85°C for 1000 hours and applying voltage they meet the specified value for load life characteristics listed above.										

# Axial Aluminium Electrolytic Capacitors **multicomp** PRO

Item	Characteristic
Marking	Printed with white colour letter on black sleeve.
Applicable Standards	Satisfies characteristics W of JIS C5141.

## Diagram

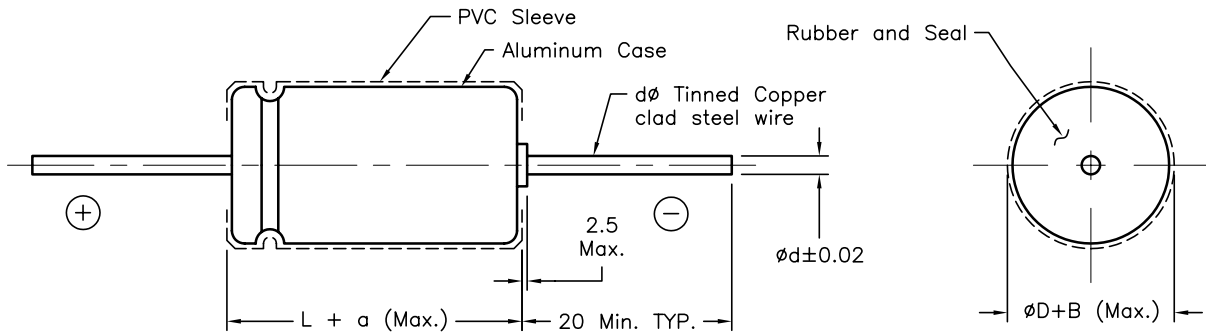

ØD	5	6	6.3	8	10	13	16	18	22	25
Ød	0.6						0.8			
a	1.5				2					
B	0.5				1					

Dimensions : Millimetres

## Specification Table

Part Number	Capacitance (µF)	Working Voltage (V DC)	Diameter (mm)	Length (mm)
MCTG101M1EB-0813P	100	25	8	13
MCTG102M1AB-1017P	1000	10	10	17

**Important Notice :** This data sheet and its contents (the "Information") belong to the members of the AVNET group of companies (the "Group") or are licensed to it. No licence is granted for the use of it other than for information purposes in connection with the products to which it relates. No licence of any intellectual property rights is granted. The Information is subject to change without notice and replaces all data sheets previously supplied. The Information supplied is believed to be accurate but the Group assumes no responsibility for its accuracy or completeness, any error in or omission from it or for any use made of it. Users of this data sheet should check for themselves the Information and the suitability of the products for their purpose and not make any assumptions based on information included or omitted. Liability for loss or damage resulting from any reliance on the Information or use of it (including liability resulting from negligence or where the Group was aware of the possibility of such loss or damage arising) is excluded. This will not operate to limit or restrict the Group's liability for death or personal injury resulting from its negligence. Multicomp Pro is the registered trademark of Premier Farnell Limited 2019.

Newark.com/multicomp-pro  
 Farnell.com/multicomp-pro  
 Element14.com/multicomp-pro

**multicomp** PRO