

Click [here](#) to ask about the production status of specific part numbers.

MAX14919

Industrial-Protected Quad-Channel Low-Side Switch

General Description

The MAX14919 industrial-protected quad-channel low-side switch features 140m Ω (typ) on-resistance (R_{ON}) per channel with integrated ± 1 kV/42 Ω surge protection for robust operation.

Resistor-settable accurate current limiting provides guaranteed operating currents in the range of 100mA to 800mA. Loads that draw large activation or inrush currents are supported using the 2x inrush load-current option. The outputs can be connected in parallel to achieve higher load currents. The four switches are pin-controlled to allow for simple and fast switching of up to 200kHz.

The device features reverse-current detection for preventing damage against load supply miswiring faults. Inductive loads are turned off rapidly using the internal high-voltage clamps. The switches are short-circuit and overload protected.

The MAX14919 quad low-side switch is available in a 6.5mm x 6.4mm footprint, 20-TSSOP package and is specified over the -40°C to +125°C operating temperature range.

Applications

- Industrial Digital Outputs
- Relay and Solenoid Drivers
- PLC and DCS Systems
- Motor Control

Benefits and Features

- 5V or 7V to 60V Supply Voltage
- 800mA Load Current per OUT
- Integrated 5V/30mA Linear Regulator
- 5V to 48V Load Voltage Range
- Up to 200kHz (min) Switching Rates
- Reduces Power and Heat Dissipation
 - 140m Ω (typ) On-Resistance per channel
 - 1.7mA (typ) Supply Current
 - Settable Load Current Limit
 - 2x Inrush Load Current Option for 10ms
- Robust Design Features
 - Internal inductive Energy Clamp at 55V(typ)
 - Short-Circuit Protection
 - Reverse Current Detection for Protection against Load-Supply Miswiring
 - ± 1 kV/42 Ω , 8 μ s/20 μ s Surge Protection
 - ± 8 kV Contact and ± 25 kV Airgap ESD Protection
 - -40°C to +125°C Operating Ambient Temperature
- **FAULT** Indication for:
 - Thermal Overload
 - Reverse Load Current Detection
 - Undervoltage Lockout on V_5 Supply
- Compact 20-pin, 6.5mm x 6.4mm TSSOP Package

Ordering Information appears at end of data sheet.

Simplified Low-Side Switch Application

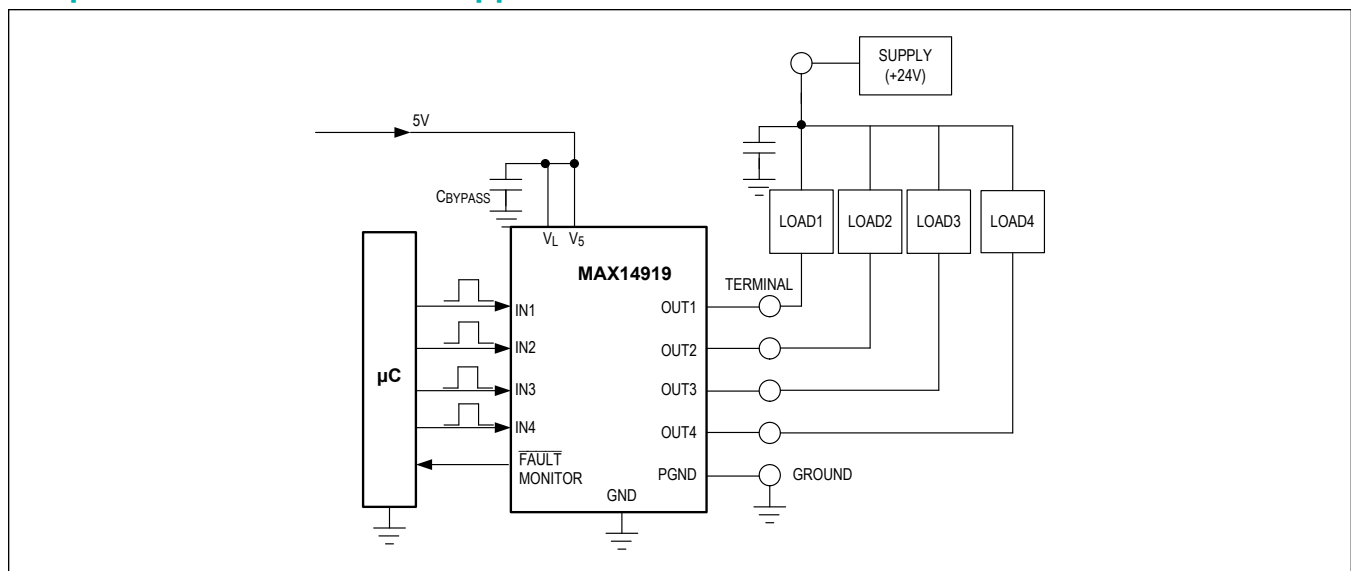

Absolute Maximum Ratings

V_{DD}	-0.3V to 65V	Continuous Power Dissipation (Single-Layer Board) ($T_A = +70^\circ\text{C}$, derate 65mW/ $^\circ\text{C}$ above $+70^\circ\text{C}$)	1739mW
V_5	-0.3V to +6V	Continuous Power Dissipation (Multilayer Board) ($T_A = +70^\circ\text{C}$, derate 55mW/ $^\circ\text{C}$ above $+70^\circ\text{C}$)	2122mW
V_L , FAULT	-0.3V to +6V	Operating Temperature Range	-40°C to 125°C
REV, RCLIM.....	-0.3V to ($V_5 + 0.3\text{V}$)	Junction Temperature	Internally Limited
IN_.....	-0.3V to +6V	Storage Temperature Range	-65°C to $+150^\circ\text{C}$
OUT1, OUT2, OUT3, OUT4	-0.3V to V_{CLAMPV}	Soldering Temperature (reflow)	260°C
OUT_ Load Current (Current limit defined by R_{LIM} resistor).....	Internally Limited		
Continuous Current (any other terminal)	$\pm 100\text{mA}$		

Stresses beyond those listed under "Absolute Maximum Ratings" may cause permanent damage to the device. These are stress ratings only, and functional operation of the device at these or any other conditions beyond those indicated in the operational sections of the specifications is not implied. Exposure to absolute maximum rating conditions for extended periods may affect device reliability.

Package Information

20 TSSOP

Package Code	U20E+3C
Outline Number	21-100132
Land Pattern Number	90-100049
THERMAL RESISTANCE, SINGLE-LAYER BOARD	
Junction-to-Ambient (θ_{JA})	46°C/W
Junction-to-Case Thermal Resistance (θ_{JC})	2°C/W
THERMAL RESISTANCE, FOUR-LAYER BOARD	
Junction-to-Ambient (θ_{JA})	37°C/W
Junction-to-Case Thermal Resistance (θ_{JC})	2°C/W

For the latest package outline information and land patterns (footprints), go to www.maximintegrated.com/packages. Note that a "+", "#", or "-" in the package code indicates RoHS status only. Package drawings may show a different suffix character, but the drawing pertains to the package regardless of RoHS status.

Package thermal resistances were obtained using the method described in JEDEC specification JESD51-7, using a four-layer board. For detailed information on package thermal considerations, refer to www.maximintegrated.com/thermal-tutorial.

Electrical Characteristics

($V_{DD} = 7\text{V}$ to 60V , $V_5 = 4.5$ to 5.5V , $V_L = 1.62\text{V}$ to 5.5V , $T_A = -40^\circ\text{C}$ to $+125^\circ\text{C}$, unless otherwise noted. Typical values are at $T_A = +25^\circ\text{C}$ and $V_{DD} = +24.0\text{V}$, $V_L = V_5$) (*Note 1*)

PARAMETER	SYMBOL	CONDITIONS		MIN	TYP	MAX	UNITS
SUPPLY (V_5, V_L)							
V_5 Supply Voltage	V_5	$V_{DD} = \text{GND}$ or unconnected		4.5	5.0	5.5	V
V_5 Supply Current	I_{V5_ON}	$V_{DD} = \text{GND}$ or unconnected	All OUT_ turned on or off		1.6	3	mA
V_5 Undervoltage-Lockout Threshold	V_5_UVLO	$V_{DD} = \text{GND}$ or unconnected	OUT_ are three-state in UVLO, V_5 falling	3.6		4.2	V
V_5 Undervoltage-Lockout Hysteresis	$V_5_UVLO_HYS$	$V_{DD} = \text{GND}$ or unconnected			0.2		V

Electrical Characteristics (continued)

($V_{DD} = 7V$ to $60V$, $V_5 = 4.5$ to $5.5V$, $V_L = 1.62V$ to $5.5V$, $T_A = -40^\circ C$ to $+125^\circ C$, unless otherwise noted. Typical values are at $T_A = +25^\circ C$ and $V_{DD} = +24.0V$, $V_L = V_5$) (*Note 1*)

PARAMETER	SYMBOL	CONDITIONS	MIN	TYP	MAX	UNITS	
V_L Supply Voltage	V_L		1.62		5.5	V	
V_L Supply Current	I_{VL}	Logic inputs at GND or V_L			20	μA	
V_L Undervoltage-Lockout Threshold	V_{L_UVLO}	V_L falling	0.7		1.4	V	
V_L Undervoltage-Lockout Hysteresis	$V_{L_UVLO_HYS}$			50		mV	
LINEAR REGULATOR (V_{DD}, V_5)							
V_{DD} Supply-Voltage Range	V_{DD}		7		60	V	
V_{DD} Supply Current	I_{DD}	$V_5 =$ No Load		1.7	3	mA	
V_5 Regulator Output Voltage	V_5	0mA to 30mA external load current	4.75	5.00	5.25	V	
V_5 Regulator Current Limit	I_{CL_V5}		35			mA	
V_5 Line Regulation		$7V \leq V_{DD} \leq 60V$, $I_{V5} = 5mA$		0.002		mV/V	
V_5 Load Regulation		$0 \leq I_{V5} \leq 20mA$		0.175		%	
SWITCH OUTPUTS (OUT₋)							
On-Resistance	R_{ON}	$I_{OUT_} = 600mA$		140	300	m Ω	
Current Limit	I_{LIM}	INRUSH = 0, or INRUSH = 1 and $t_{LIM} > 15ms$	$R_{LIM} = 100k\Omega$	140	270	mA	
			$R_{LIM} = 27k\Omega$	700	800		900
			$R_{LIM} = open$	650			950
Inrush Current Limit	I_{LIM}	INRUSH = 1 or high, for 10ms after switch turn-on	$2 \times I_{LIM}$			mA	
Inductive Clamp Voltage	V_{CLAMP}	OUT ₋ is OFF, $I_{OUT_} = 500mA$	49	55		V	
Off-State Leakage Current at OUT ₋	I_{LEAK}	IN ₋ = low, $V_{OUT_} = 0V$ to $45V$. (<i>Note 2</i>)	-15		+15	μA	
CLIM Voltage	V_{CLIM}			1.2		V	
CLIM Short Resistance-Threshold Value	R_{LIM_SHORT}		4.5	6.5	9	k Ω	
CLIM Open Resistance-Threshold Value	R_{LIM_OPEN}		400	650	1000	k Ω	
Switch Turn-Off Propagation Delay (Low-to-High)	t_{OFF}	Delay from IN ₋ switching low to OUT ₋ rising by 0.5V, $R_L = 48\Omega$, $C_L = 0.1nF$, $V_{LOAD} = 24V$ (see <i>Figure 1</i>)		105	300	ns	
Switch Turn-On Propagation Delay (High-to-Low)	t_{ON}	Delay between IN ₋ switching high to OUT ₋ falling by 0.5V, $R_L = 48\Omega$, $V_{LOAD} = 24V$ (see <i>Figure 1</i>)		70	300	ns	
Output Fall-Time	t_F	Output falling 80% to 20% of final value, $V_{LOAD} = 24V$, $R_L = 48\Omega$, $C_L = 0.1nF$ (see <i>Figure 2</i>)		160	250	ns	

Electrical Characteristics (continued)

($V_{DD} = 7V$ to $60V$, $V_5 = 4.5$ to $5.5V$, $V_L = 1.62V$ to $5.5V$, $T_A = -40^\circ C$ to $+125^\circ C$, unless otherwise noted. Typical values are at $T_A = +25^\circ C$ and $V_{DD} = +24.0V$, $V_L = V_5$) (*Note 1*)

PARAMETER	SYMBOL	CONDITIONS	MIN	TYP	MAX	UNITS
LOAD SUPPLY REVERSE POLARITY DETECT (REV)						
Reverse Current-Detect Threshold	$I_{TH_OUT_REV_ON}$	$V_5 > V_{5_UVLO}$, $IN_ =$ high, current flow out of any $OUT_$	-190	-150	-115	mA
	$I_{TH_OUT_REV_OFF}$	$V_5 > V_{5_UVLO}$, $IN_ =$ low, current flow out of any $OUT_$	-185	-150	-95	
REV Output-Pullup Current	I_{REV_ON}	$V_5 > V_{5_UVLO}$, $I_{OUT_} > I_{TH_OUT_REV}$, $V_{REV} = V_5 - 1V$	25	45		μA
REV Output-Pulldown Resistance	R_{REV_OFF}	$V_5 > V_{5_UVLO}$, $I_{OUT_} < I_{TH_OUT_REV}$		10		Ω
Auto-Retry Delay	t_{REV_AR}	Delay until REV output is turned back on after reverse-detection turn-off		2		s
LOGIC INPUTS ($IN_$, $INRUSH$)						
Input-Voltage High	V_{IH}		$0.8 \times V_L$			V
Input-Voltage Low	V_{IL}				$0.2 \times V_L$	V
Input-Threshold Hysteresis	V_{I_TH}		0.1			V
Input-Pulldown Resistor	$R_{PULLDOWN}$	All logic input pins	200			k Ω
LOGIC OUTPUT (FAULT)						
Output Logic Low	V_{OL}	$I_{LOAD} = 5mA$			0.33	V
Three-State Leakage	I_{LKG}	Open-drain output off, $V_{PULLUP} = 5V$ (<i>Note 2</i>)	-1		+1	μA
THERMAL PROTECTION						
Channel Thermal-Shutdown Temperature	T_{JSHDN}	Junction temperature rising, per channel		160		$^\circ C$
Channel Thermal-Shutdown Hysteresis	T_{JSHDN_HYST}			15		$^\circ C$
Chip Thermal Shutdown	T_{CSHDN}	Temperature rising		150		$^\circ C$
Chip Thermal-Shutdown Hysteresis	$T_{CSHDN_HYS_T}$			10		$^\circ C$
LDO Shutdown Temperature	T_{DSHDN}	Temperature rising		160		$^\circ C$
EMC						
Surge Tolerance	V_{SURGE}	$OUT_$ to GND, IEC 61000-4-5 with 42Ω		± 1		kV
ESD IEC Contact Discharge	V_{ESD_C}	$OUT_$ to GND, IEC 61000-4-2		± 8		kV
ESD IEC Air Discharge	V_{ESD_A}	$OUT_$ to GND, IEC 61000-4-2		± 25		kV
ESD	V_{ESD}	All other pins. Human Body Model		± 2		kV

Note 1: All units are production tested at $T_A = +25^\circ C$. Specifications over temperature are guaranteed by design.

Note 2: Current into the device is positive and current out of the device is negative.

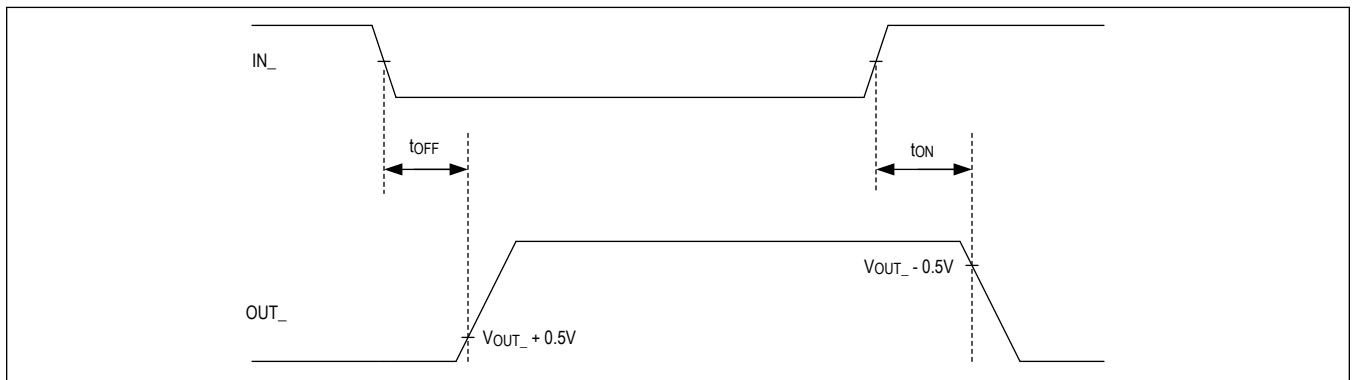

Figure 1. IN_ to OUT_ Propagation Times

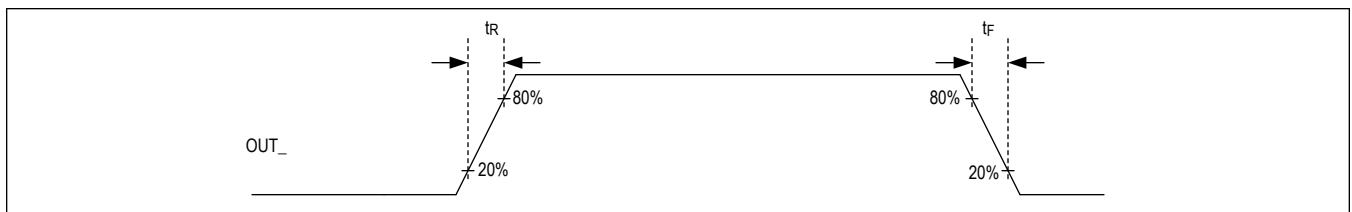
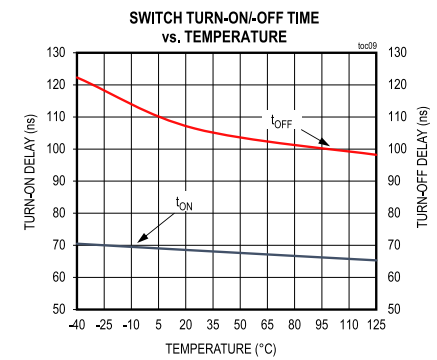
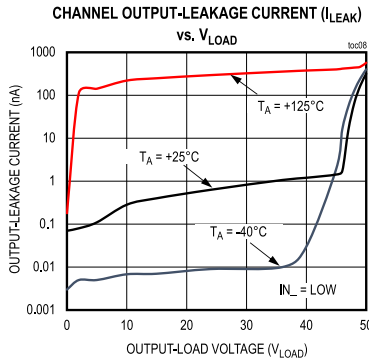
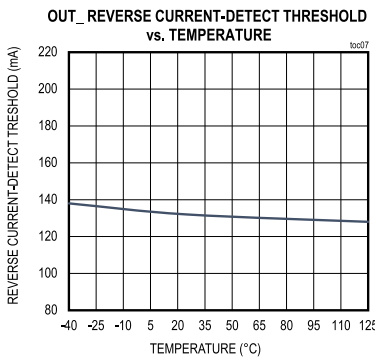
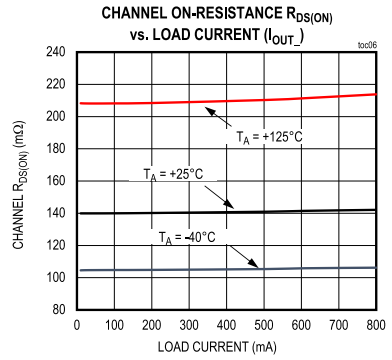
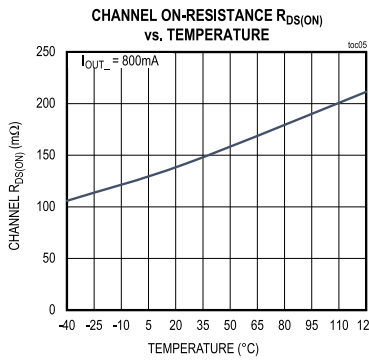
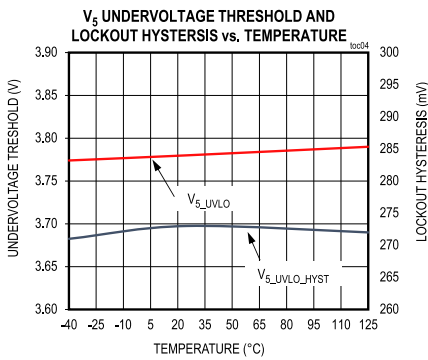
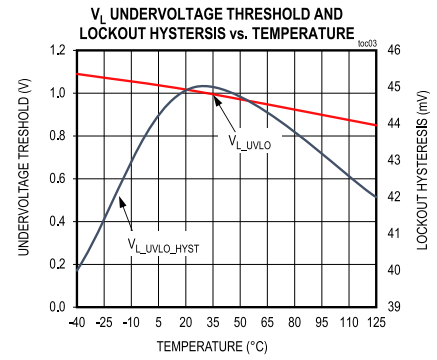
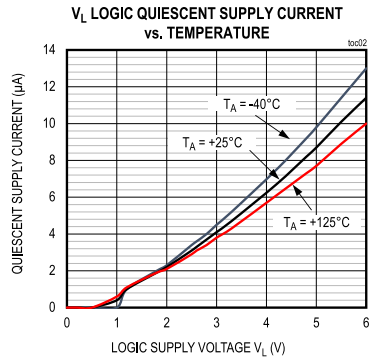
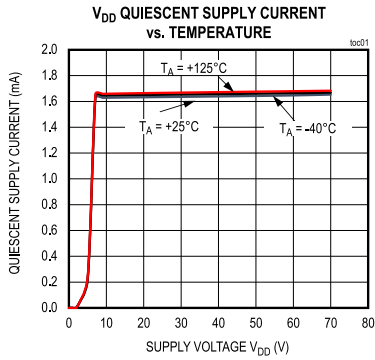

Figure 2. Output Channel Rise and Fall Times

Typical Operating Characteristics

($V_{DD} = +24V$, $V_L = +3.3V$, INRUSH = LOW, $T_A = 25^\circ C$ unless otherwise noted.)



Typical Operating Characteristics (continued)

($V_{DD} = +24V$, $V_L = +3.3V$, INRUSH = LOW, $T_A = 25^\circ C$ unless otherwise noted.)

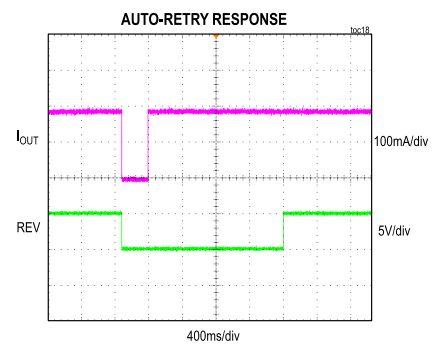
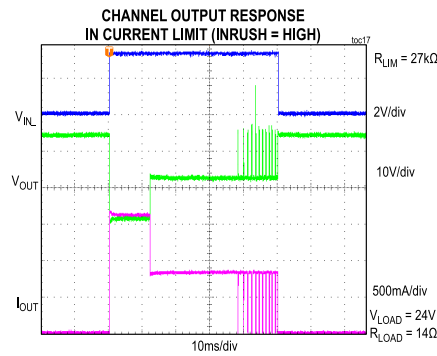
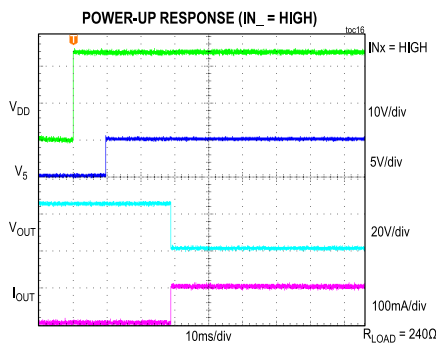
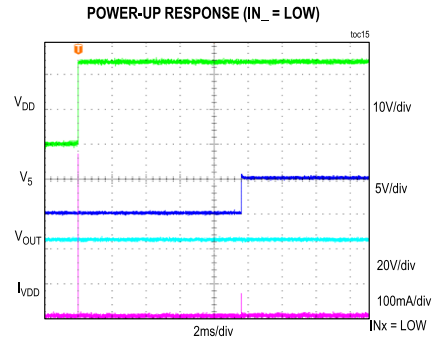
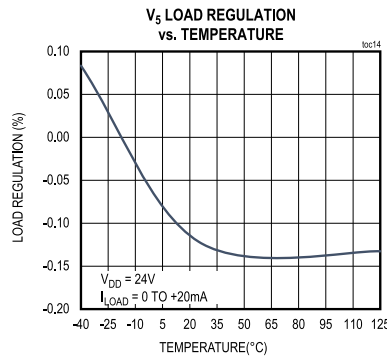
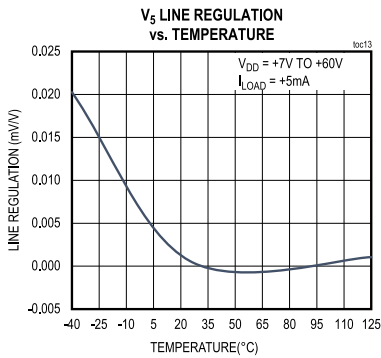
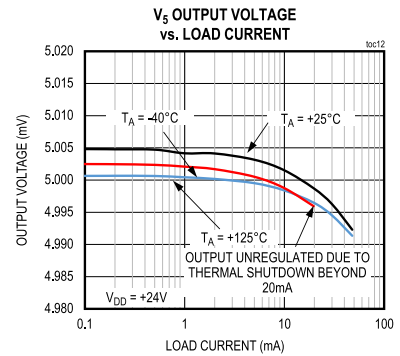
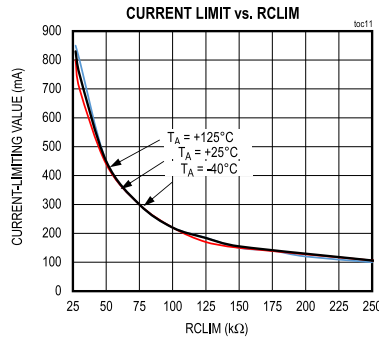
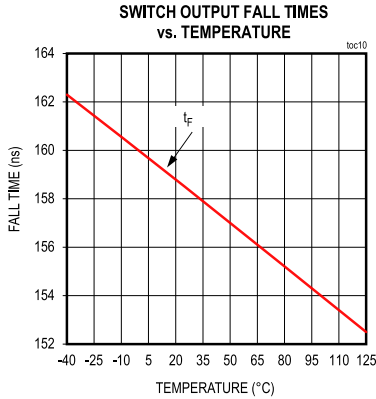

Pin Configuration

MAX14919 Pin Configuration

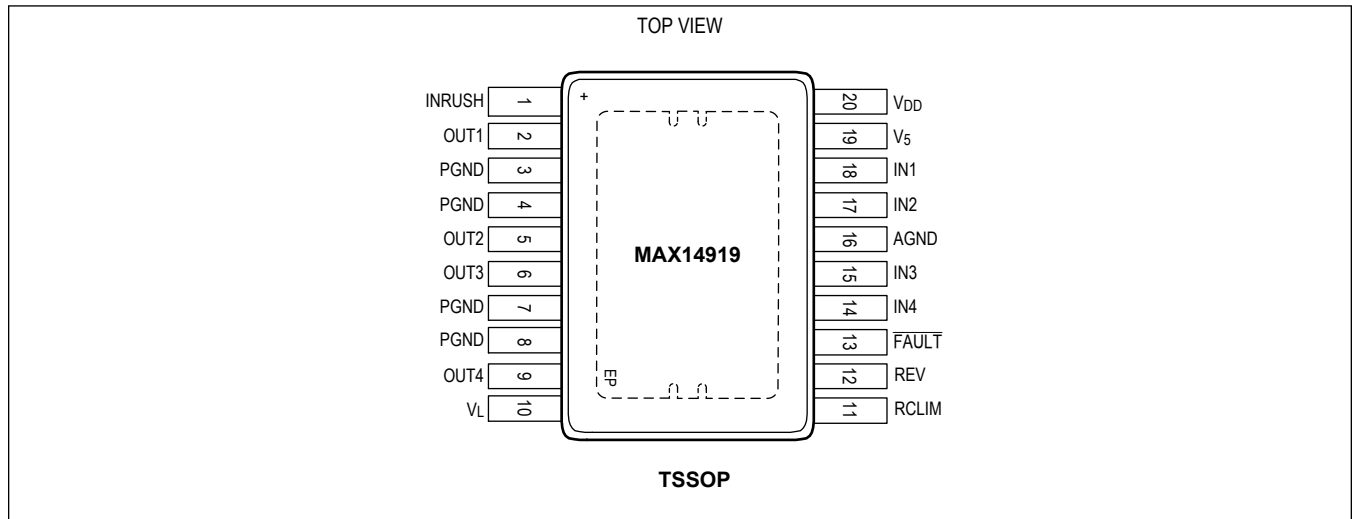

Pin Description

PIN	NAME	FUNCTION
POWER SUPPLY		
20	V _{DD}	24V Supply Input to Linear Regulator. Bypass V _{DD} to GND using a 1μF ceramic capacitor. If the MAX14919 is powered by an external V ₅ supply and not V _{DD} , the V _{DD} input must either be connected to GND or left unconnected.
3, 4, 7, 8	PGND	Power Ground. Connect to Exposed Pad (EP).
16	AGND	Analog Ground. Connect to Exposed Pad (EP).
19	V ₅	5V Supply Input or 5V Linear Regulator Output. Bypass V ₅ to GND using a 1μF ceramic capacitor. V ₅ is the primary chip supply and is required for normal operation
10	V _L	Logic Supply. Connect a supply voltage between 1.6V and 5.5V to V _L . Connect a 100nF bypass cap to V _L
SWITCH CONTROL		
18	IN1	Switch 1 Control Logic Input. IN1 has a weak pulldown to GND. Drive IN1 high to close the OUT1 switch.
17	IN2	Switch 2 Control Logic Input. IN2 has a weak pulldown to GND. Drive IN2 high to close the OUT2 switch.
15	IN3	Switch 3 Control Logic Input. IN3 has a weak pulldown to GND. Drive IN3 high to close the OUT3 switch.
14	IN4	Switch 4 Control Logic Input. IN4 has a weak pulldown to GND. Drive IN4 high to close the OUT4 switch.
SWITCH OUTPUTS		
2	OUT1	Low-Side Switch 1 Output
5	OUT2	Low-Side Switch 2 Output
6	OUT3	Low-Side Switch 3 Output
9	OUT4	Low-Side Switch 4 Output

Pin Description (continued)

PIN	NAME	FUNCTION
Configuration		
1	INRUSH	Inrush-Enable Logic Input. Drive INRUSH high to enable 2x current limiting for 100mA (min) after any switch is turned on (using IN ₊). Drive INRUSH low to disable inrush current.
11	RCLIM	Load Current-Limit Control Resistor. Connect a resistor between RCLIM and GND to define the maximum load current through each switch. See the Current Limiting section for details.
DIAGNOSTICS SIGNALLING		
12	REV	REV Logic Output. Connect REV to the gate of an external nMOS transistor for supply-load reverse-polarity protection. If an external nMOS is not used for load reverse protection, leave REV unconnected.
13	$\overline{\text{FAULT}}$	Global Overload Open-Drain Output. The $\overline{\text{FAULT}}$ transistor turns on low when any of the OUT ₊ switches are in thermal overload or the chip is in thermal shutdown. Connect a pullup resistor to V _L .
EXPOSED PAD		
—	EP	Exposed Pad. Connect EP to GND, PGND1, or PGND2.

Functional Diagrams

MAX14919

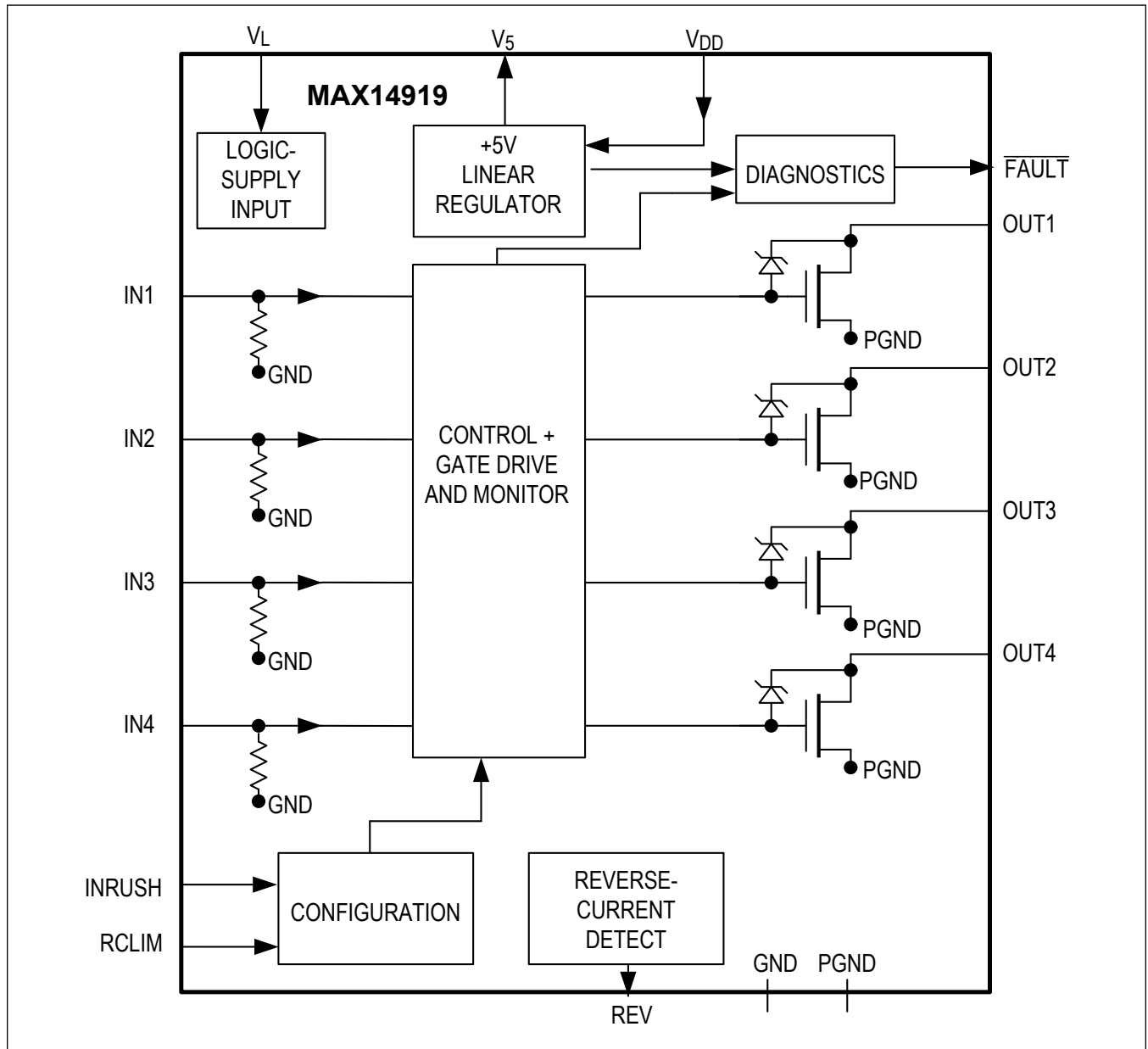

Detailed Description

The MAX14919 is a quad industrial low-side switch. Each low-side switch has 140mΩ (typ) on-resistance at up to 800mA load current. The four switches are pin-controlled, allowing parallel interface and high switching rates of over 200kHz on each channel. The maximum load current allowed through the switches can be set to fit different system needs. The switch outputs are protected against short circuits to voltages in the range of 0V to 49V and are protected against thermal overload. Integrated line-to-GND surge protection of up to ±1kV/42Ω makes external TVS protection unnecessary.

The device offers additional control for protection and diagnostics indicating thermal overload, reverse-load detect, V₅ supply undervoltage, and faults on the RCLIM current-limit setting pin.

The internal active clamps limit the OUT_ voltage to +55V (typ) enabling fast turn-off of inductive loads.

Supply Inputs

Supply Powering Options with V_{DD} and V₅

The MAX14919 offers flexible powering options. It can either be powered by V_{DD} or by V₅. The V_{DD} power-supply input is able to support a wide supply-voltage range from +7V to +60V with a typical case of +24V industrial power. The internal low-dropout regulator (LDO) handles the wide input to provide a stable +5V output. Applications with limited available system power or unregulated supplies are able to power MAX14919 without the need of external power converters.

In the presence of a stable +5V external supply, the internal LDO can be bypassed and the MAX14919 only powered by 5V. The V₅ power pin acts as a supply input when V_{DD} is grounded/unconnected and handles input with +4.5V to +5.5V supplies. V₅ is the primary power supply for MAX14919 powering the internal control and analog blocks. The internal LDO can be bypassed by either connecting V_{DD} to GND or by leaving V_{DD} unconnected.

5V Linear Regulator

The integrated 5V linear regulator (V₅) can supply up to 30mA load current. Note that linear regulators have high power dissipation when high load currents are drawn while powered from high supply voltage. Calculate the power dissipation in the regulator as $P_{DIS} (W) = (V_{DD} - V_5) \times I_{V_5}$. The power dissipation might be excessive for high V₅ load currents in combination with high V_{DD} supply voltage resulting in self-heating of the device. Verify that the MAX14919 maximum thermal ratings are not exceeded at the highest operating temperatures.

When the MAX14919 enters thermal shutdown, the V₅ linear regulator is automatically turned off at 160°C. The regulator turns on automatically when the chip temperature drops by 15°C (typ).

Logic Supply Input V_L

The V_L logic-supply input supports a wide logic-voltage range of +1.62V to +5.5V. V_L can either be powered by V₅ or externally supplied by +1.8V (typ) or +3.3V (typ) to enable interface with microcontrollers, FPGAs, or digital isolators. This supply input powers internal interface and logic blocks of MAX14919.

Undervoltage Lockout

When the V_{DD}, V₅, or V_L supply voltages are under their respective UVLO thresholds, all OUT_ switches are off.

Logic Interface

The logic interface requires a V_L supply in the range of +1.62V to +5.5V. This ensures that the logic levels on logic I/O pins are CMOS-compliant. If used, connect pullup resistors to the open-drain logic outputs. If not used, connect the open-drain logic outputs to GND.

FAULT Signaling

FAULT is a global fault indication that is an open drain logic output that transitions active low when the MAX14919 detects a fault condition. When the MAX14919 exits fault status and all switches are in normal operation, the FAULT pin transitions passive high. FAULT is asserted for any of these conditions:

- Chip thermal shutdown
- Any of the OUT switches are in thermal overloads; thus, are turned off.
- Reverse current detected at OUT_
- V₅ UVLO
- Short-circuit detected on the RCLIM pin.

During power-up of the device, FAULT is asserted until V₅ goes above its undervoltage-lockout condition (V_{5_UVLO}). FAULT is indicated if any one of the switch output has thermal overload or reverse-load connection, while the other channels are operating normally. The FAULT output is independent of the IN_ pin logic.

Chip Thermal Protection

All switches are constantly monitored while the MAX14919 is powered with V₅ > V_{5_UVLO}. When the MAX14919 chip temperature rises above the thermal shutdown threshold of 150°C (T_{CSDN}), the chip enters thermal shutdown protection and all OUT switches are turned off until the chip temperature drops below 140°C (T_{CSDN} - T_{CSDN_HYS}). In this condition, the FAULT output is set.

If an output switch temperature rises above 160°C (channel thermal-shutdown temperature T_{JSHDN}), that switch output (OUT_x) is shut off. When the chip temperature falls by the hysteresis amount (T_{JSHDN_HYS}), the OUT_ switch is restored to normal operation.

The integrated low dropout regulator features a separate temperature sensor that monitors the internal temperature due to the LDO power dissipation. If the internal LDO temperature rises above 160°C (T_{DSDN}) the LDO is turned off. The LDO wakes up after cooling down by (T_{DSDN_HYST}).

Current Limiting

The MAX14919 has a settable current limiting common to all four output switches (OUT1 to OUT4). The load current limiting can be set to between 100mA and 800mA depending on the value of the resistor applied at the RCLIM pin.

Connect a resistor (R_{LIM}) from RCLIM to GND to set the required current limit. The equation to determine R_{LIM} for a known current to be limited (I_{LIM}) is given by:

$$R_{LIM}(k\Omega) = \frac{V_{CLIM} \times K1}{(I_{LIM} - K2)(mA)}$$

where,

$$V_{CLIM} = 1.2V$$

$$K1 = 17260 \text{ (min), } 18000 \text{ (typ), } 19418 \text{ (max)}$$

$$K2 \text{ (mA)} = -67.1 \text{ (min), } 0 \text{ (typ), } 36.98 \text{ (max)}$$

For example, the R_{LIM} resistor to ensure the current limit is always higher than 600mA, which is the maximum operating load current of system is:

$$R_{LIM}(k\Omega) = \frac{V_{CLIM} \times K1(\text{min})}{(I_{LIM} - K2(\text{min}))(\text{mA})} = \frac{1.2 \times 17260}{(600 - (-67.1))(\text{mA})} = 31.05k\Omega$$

If no resistor is connected to the RCLIM input (i.e., RCLIM is unconnected) or R_{LIM} is more than 650kΩ, the I_{LIM} is internally set to 800mA. If the R_{LIM} resistor is less than 6.5kΩ (typ), all OUT_ switches are turned off. RCLIM is short-circuit protected.

When the load current is higher than the set I_{LIM} current in any of the outputs, the device forces the associated switch to limit the current to the I_{LIM} (mA) value. In current-limit operation, the OUT_ voltage rises and the OUT_ switch

consequentially heats up proportionally to the $V_{OUT} \times I_{LIM}$ power dissipation. The limiting is done indefinitely until the channel is turned-off or the fault condition is removed.

Inrush Current Mode

The MAX14919 offers inrush mode that supports loads that draw higher currents during turn-on. In INRUSH mode, each switch provides at least double of the current set by the R_{LIM} resistor for the INRUSH duration of 10ms (min). Setting the INRUSH logic-input high enables the inrush mode allowing $2 \times I_{LIM}$ for up to 10ms. After the INRUSH period, the switch current limiting reverts to the value set by I_{LIM} .

System Protection

Reverse-Current Detection

In case of reverse currents flowing out of OUT_* due to a load-supply miswiring fault, the MAX14919 offers reverse-current detection (REV) to protect the device against damage caused by high reverse currents. Reverse currents are drawn out of OUT_* when a negative voltage is applied to OUT_* with respect to GND/PGND and the switch OUT_* is in an on or off state. The reverse currents are typically large due to the OUT_* switch low-resistance both in on and off states. When a reverse current larger than 150mA is detected on any of the OUT_* pins, the REV output is immediately driven low. REV can be used to turn off the external nFET, which opens the GND connection to the external load field-supply unit.

After a reverse current is detected, REV stays low and is automatically set high after 2 seconds. This auto-retry scheme continues indefinitely until the reverse connection is removed. The REV output can be used to turn on/off an external nFET to disconnect the MAX14919 from the load in case of reverse-current detection. The on-resistance of the external nFET should be chosen such that it does not contribute significantly to a channel R_{ON} since all four OUT_* currents flow through the reverse-protecting nFET. Its R_{ON} should be significantly less than $(1/4)^{th}$ of the R_{ON} of the OUT_* (less than $35m\Omega$ typ).

Transient Energy Protection

The MAX14919 features an integrated clamp at each of its four channel outputs. In typical applications, the integrated clamp avoids an external clamp on each of its outputs reducing component cost and board space. In case of an overvoltage event caused by surge, ESD, or inductive load turn-off, the clamp turns on at +55V (typ) to dissipate the energy.

Short-Circuit and Overcurrent Protection

The device outputs are designed to handle hard short-circuits as well as overcurrents. In case of a short-circuit at OUT_* to field supply with the switch turned on, the device actively regulates the current to I_{LIM} . The shorted switch channel temperature increases at a rate determined by the power dissipation: OUT_* voltage $\times I_{LIM}$. The switch enters thermal shutdown when its temperature is greater than 160°C. After the device cools down by T_{JSHDN_HYS} (°C), the switch is automatically turned on if its associated IN_* input is high. The MAX14919 switch outputs indefinitely cycle into and out of thermal shutdown until the switch is turned off or the short-circuit is removed.

Applications Information

Output Parallelization

The MAX14919 device supports paralleling of channels in applications with a higher load-current requirement. The channels that are paralleled should be connected together at the output and input, respectively. When multiple outputs are connected in parallel, the resulting current limit is the sum of the each output's current limit. For example, paralleling of two channels doubles the available load current.

When multiple outputs OUT_ are paralleled, an external zener-diode (ZD) clamp might be required per output for quenching the energy during inductive load turnoff. The external ZD-clamp voltage must be lower than the minimum internal-clamp voltage (49V min).

Board Layout

High-current, low R_{ON} switches require proper layout and design procedures for optimum performance. Ensure that power-supply bypass capacitors are placed as close as possible to the device. Ensure that the PGND and GND pins are interconnected to have the least on-board resistance. In this case, a 1 μ F capacitor should be placed to the ground plane as close to the V_{DD} pin as possible.

Connect the exposed pad to a large GND plane to dissipate heat in case of large load currents. Either the top layer or an inner or the bottom PCB layer is used for heat conduction. Use many vias under the exposed pad ("via farm") to efficiently contact the inner and bottom layers.

Surge Protection

Each OUT_ (OUT1 to OUT4) of the MAX14919 is protected against IEC 61000-4-5 (1.2 μ s/ 50 μ s) surges of up to $\pm 1\text{kV}/(42\Omega + 0.5\mu\text{F})$ without the need for external protection diodes from OUT_ to PGND.

Inductive Demagnetization

During turn-off of inductive loads by an OUT_ low-side switch, the kickback voltage generated by the inductance is clamped by the internal clamp to a voltage of +55V (typ) relative to PGND allowing fast demagnetization. Large load inductance and higher load currents in the inductive load increase the time until the inductance is demagnetized. This increases the energy in the clamp; hence, the internal temperature of MAX14919 and can result in a thermal overload with $\overline{\text{FAULT}}$ set low. Since large energy is dissipated in the MAX14919 device through the voltage clamp, the user must design the system keeping in mind the inductance of the load and its operating current. Failure to do so results in damage to the device.

Each switch is able to dissipate up to 200mJ of clamp energy during inductive load clamping at +125°C junction temperature (T_J).

Typical Application Circuits

Isolated Quad-Channel Digital-Output Application with Reverse-Load Polarity Protection

This *Typical Application Circuit* illustrates an isolated quad-channel low-side digital output with reverse-load polarity protection with a 800mA current limit. An unregulated supply from the transformer driver (MAX258) is supplied to the V_{DD} input of MAX14919. The internal +5V LDO output is connected to the V_L logic-supply input. MAX14919 V₅ output powers the MAX14483 isolator. MAX14483 enables a +3.3V to +5V interface while providing 3.75kV_{RMS} isolation. The field power-ok signal is a diagnostic provided by MAX14483 to ensure field-side power is present while transmitting signals to the MAX14919 device. An external nFET (NTTFS5820NLTAG) along with the REV output provides reverse-load polarity protection. When OUT₋ and COM terminals are miswired, the currents flows into COM and out of OUT₋ channel. When the magnitude of current is greater than 150mA, the REV output is forced low, which switches off the nFET; thereby, cutting the path between COM and OUT₋. The unipolar TVS (SMCJ36A) protects the external nFET for surge when the nFET is off.

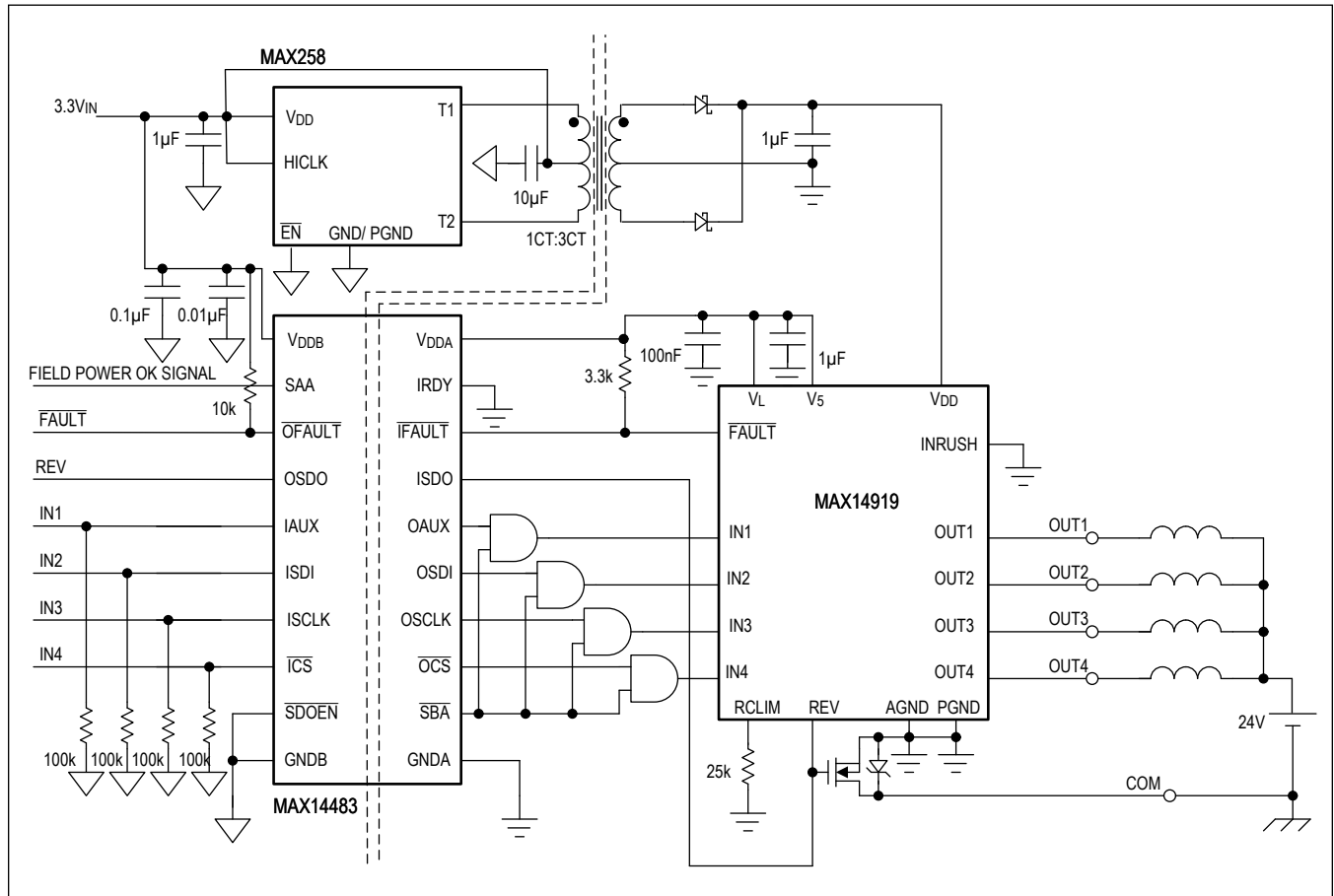

Ordering Information

PART NUMBER	TEMP RANGE	PIN-PACKAGE
MAX14919AUP+	-40°C to +125°C	20 TSSOP-EP*
MAX14919AUP+T	-40°C to +125°C	20 TSSOP-EP*
MAX14919ATP+**	-40°C to +125°C	20 TQFN
MAX14919ATP+T**	-40°C to +125°C	20 TQFN

+Denotes a lead(Pb)-free/RoHS-compliant package.

T = Tape and reel.

*EP = Exposed pad.

**Future product — contact factory for availability

Revision History

REVISION NUMBER	REVISION DATE	DESCRIPTION	PAGES CHANGED
0	10/20	Release for Market Intro	—

For pricing, delivery, and ordering information, please visit Maxim Integrated's online storefront at <https://www.maximintegrated.com/en/storefront/storefront.html>.

Maxim Integrated cannot assume responsibility for use of any circuitry other than circuitry entirely embodied in a Maxim Integrated product. No circuit patent licenses are implied. Maxim Integrated reserves the right to change the circuitry and specifications without notice at any time. The parametric values (min and max limits) shown in the Electrical Characteristics table are guaranteed. Other parametric values quoted in this data sheet are provided for guidance.