

ENVIRONMENTAL BACKSHELL



These Backshells from Amphenol not only provide the cable support and strain relief, but ensure the cable sealing and environment protection by means of high quality sealing grommet and grommet follower. The strain relief nut is tightened squeezing the grommet on to the cable jacket during assembly. These Backshells from Amphenol give 6 feet water sealing protection when used with perfectly jacketed cable and are suitable for harsh environment applications.

For Connector Group		Page No.
J	→	II-1 - II-11
K	→	II-12 - II-16
L	→	II-17 - II-21
M	→	II-22 - II-26
N	→	II-27 - II-32

Note: For Connector group Identification refer Table 1 - A, B, C, D (Page 7-11) and for Material / Plating Finish, Refer Table-2 (Page 12)



Connector Group - J

Straight

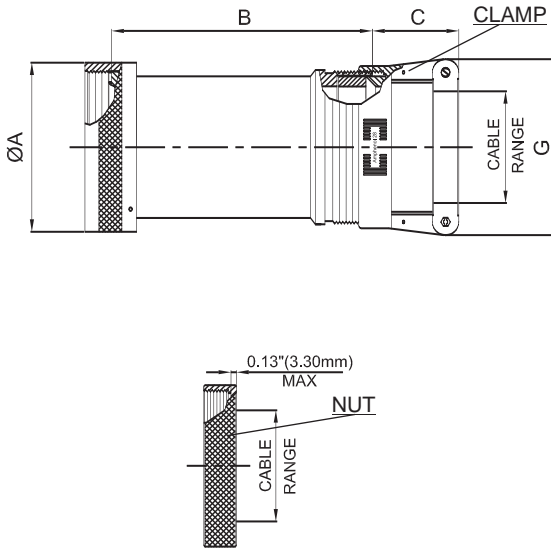

Amphenol Part Number

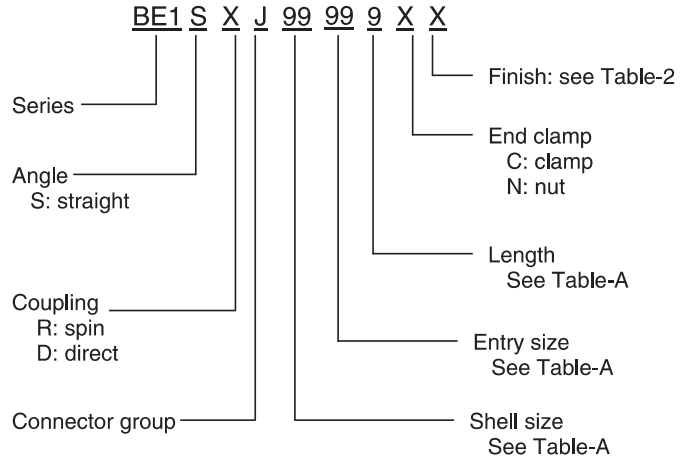

MIL Part Number

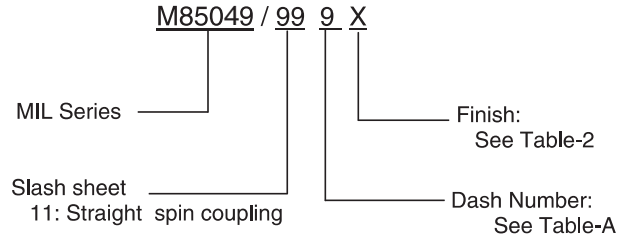

NOTE: * For more cable entry and length options, contact factory

TABLE - A												
AMPHENOL PART NUMBER DESIGNATOR			MIL PART NUMBER DESIGNATOR	CONNECTOR SHELL SIZE	A DIA. (MAX)		B (MAX)		C (REF)		G (MAX)	
SHELL SIZE	ENTRY SIZE	LENGTH	DASH NO		INCH	MM	INCH	MM	INCH	MM	INCH	MM
08	01	1	5	8	0.62	15.67	2.13	54.10	1.03	26.09	0.96	24.31
		2	6		0.62	15.67	3.13	79.50	1.03	26.09	0.96	24.31
	02	1	7*		0.62	15.67	2.88	73.15	1.03	26.09	1.15	29.08
		2	8*		0.62	15.67	3.88	98.55	1.03	26.09	1.15	29.08
10	01	1	9	10	0.73	18.64	2.13	54.10	1.03	26.09	0.96	24.31
		2	10		0.73	18.64	3.13	79.50	1.03	26.09	0.96	24.31
	02	1	11*		0.73	18.64	2.88	73.15	1.03	26.09	1.15	29.08
		2	12*		0.73	18.64	3.88	98.55	1.03	26.09	1.15	29.08
	03	1	136		0.73	18.64	2.13	54.10	1.03	26.09	1.15	29.08
		2	137		0.73	18.64	3.13	79.50	1.03	26.09	1.15	29.08
12	01	1	13	7/12	0.86	21.79	2.13	54.10	1.03	26.09	1.15	29.08
		2	14		0.86	21.79	3.13	79.50	1.03	26.09	1.15	29.08
	02	1	15*		0.86	21.79	2.88	73.15	1.03	26.09	1.33	33.83
		2	16*		0.86	21.79	3.88	98.55	1.03	26.09	1.33	33.83
	03	1	111		0.86	21.79	2.13	54.10	1.03	26.09	1.33	33.83
		2	114		0.86	21.79	2.13	54.10	1.03	26.09	0.96	24.31
	04	1	115		0.86	21.79	3.13	79.50	1.03	26.09	0.96	24.31
		2	118		0.86	21.79	2.13	54.10	1.03	26.09	1.33	33.83
	05	1	138		0.86	21.79	2.13	54.10	1.03	26.09	1.33	33.83
		2	139		0.86	21.79	3.13	79.50	1.03	26.09	1.33	33.83

Table Continued

TABLE - A												
AMPHENOL PART NUMBER DESIGNATOR			MIL PART NUMBER DESIGNATOR	CONNECTOR SHELL SIZE	A DIA. (MAX)		B (MAX)		C (REF)		G (MAX)	
SHELL SIZE	ENTRY SIZE	LENGTH	DASH NO		INCH	MM	INCH	MM	INCH	MM	INCH	MM
14	01	1	17	12/14	0.98	24.99	2.13	54.10	1.03	26.09	1.33	33.83
		2	18		0.98	24.99	3.13	79.50	1.03	26.09	1.33	33.83
	02	1	19*		0.98	24.99	2.88	73.15	1.06	26.90	1.55	39.40
		2	20*		0.98	24.99	3.88	98.55	1.06	26.90	1.55	39.40
	03	1	116		0.98	24.99	2.13	54.10	1.03	26.09	1.15	29.08
		2	117		0.98	24.99	3.13	79.50	1.03	26.09	1.15	29.08
	04	1	150		0.98	24.99	2.13	54.10	1.03	26.09	0.96	24.31
		2	151		0.98	24.99	3.13	79.50	1.03	26.09	0.96	24.31
16	01	1	21	19/16	1.11	28.24	2.13	54.10	1.06	26.90	1.55	39.40
		2	22		1.11	28.24	3.13	79.50	1.06	26.90	1.55	39.40
	02	1	23*		1.11	28.24	2.88	73.15	1.16	29.36	1.77	44.96
		2	24*		1.11	28.24	3.88	98.55	1.16	29.36	1.77	44.96
	03	1	112		1.11	28.24	2.13	54.10	1.03	26.09	1.15	29.08
		2	113		1.11	28.24	3.13	79.50	1.03	26.09	1.15	29.08
	04	1	118		1.11	28.24	2.13	54.10	1.03	26.09	1.33	33.83
		2	119		1.11	28.24	3.13	79.50	1.03	26.09	1.33	33.83
	05	1	152		1.11	28.24	2.13	54.10	1.03	26.09	0.96	24.31
		2	153		1.11	28.24	3.13	79.50	1.03	26.09	0.96	24.31
18	01	1	25	27/18	1.22	30.94	2.13	54.10	1.03	26.09	1.33	33.83
		2	26		1.22	30.94	3.13	79.50	1.03	26.09	1.33	33.83
	02	1	27		1.22	30.94	2.13	54.10	1.06	26.90	1.55	39.40
		2	28		1.22	30.94	3.13	79.50	1.06	26.90	1.55	39.40
	03	1	29*		1.22	30.94	2.88	73.15	1.16	29.36	1.77	44.96
		2	30*		1.22	30.94	3.88	98.55	1.16	29.36	1.77	44.96
	04	1	120		1.22	30.94	2.13	54.10	1.03	26.09	0.96	24.31
		2	121		1.22	30.94	3.13	79.50	1.03	26.09	0.96	24.31
	05	1	122		1.22	30.94	2.13	54.10	1.03	26.09	1.15	29.08
		2	123		1.22	30.94	3.13	79.50	1.03	26.09	1.15	29.08
20	01	1	31	37/20	1.35	34.16	3.13	79.50	1.03	26.09	1.33	33.83
		2	32		1.35	34.16	4.13	104.90	1.03	26.09	1.33	33.83
	02	1	33		1.35	34.16	3.13	79.50	1.06	26.90	1.55	39.40
		2	34		1.35	34.16	4.13	104.90	1.06	26.90	1.55	39.40
	03	1	35*		1.35	34.16	3.88	98.55	1.16	29.36	1.77	44.96
		2	36*		1.35	34.16	4.88	123.95	1.16	29.36	1.77	44.96
	04	1	37*		1.35	34.16	3.88	98.55	1.38	34.93	2.11	53.67
		2	38*		1.35	34.16	4.88	123.95	1.38	34.93	2.11	53.67
	05	1	124		1.35	34.16	3.13	79.50	1.03	26.09	1.15	29.08
		2	125		1.35	34.16	4.13	104.90	1.03	26.09	1.15	29.08
	06	1	140		1.35	34.16	3.13	79.50	1.16	29.36	1.77	44.96
		2	141		1.35	34.16	4.13	104.90	1.16	29.36	1.77	44.96
22	01	1	39	22	1.47	37.29	3.13	79.50	1.03	26.09	1.33	33.83
		2	40		1.47	37.29	4.13	104.90	1.03	26.09	1.33	33.83
	02	1	41		1.47	37.29	3.13	79.50	1.06	26.90	1.55	39.40
		2	42		1.47	37.29	4.13	104.90	1.06	26.90	1.55	39.40
	03	1	43		1.47	37.29	3.13	79.50	1.16	29.36	1.77	44.96
		2	44		1.47	37.29	4.13	104.90	1.16	29.36	1.77	44.96
	04	1	45*		1.47	37.29	3.88	98.55	1.38	34.93	2.11	53.67
		2	46*		1.47	37.29	4.88	123.95	1.38	34.93	2.11	53.67
	05	1	126		1.47	37.29	3.13	79.50	1.03	26.09	0.96	24.31
		2	127		1.47	37.29	4.13	104.90	1.03	26.09	0.96	24.31
	06	1	128		1.47	37.29	3.13	79.50	1.03	26.09	1.15	29.08
		2	129		1.47	37.29	4.13	104.90	1.03	26.09	1.15	29.08
	07	1	142		1.47	37.29	3.13	79.50	1.38	34.93	2.11	53.67
		2	143		1.47	37.29	4.13	104.90	1.38	34.93	2.11	53.67

Table Continued

Connector Group - J

Straight

TABLE - A														
AMPHENOL PART NUMBER DESIGNATOR			MIL PART NUMBER DESIGNATOR	CONNECTOR SHELL SIZE	A DIA. (MAX)		B (MAX)		C (REF)		G (MAX)			
SHELL SIZE	ENTRY SIZE	LENGTH	DASH NO		INCH	MM	INCH	MM	INCH	MM	INCH	MM		
24	01	1	47	24	1.59	40.46	3.13	79.50	1.06	26.90	1.55	39.40		
		2	48		1.59	40.46	4.13	104.90	1.06	26.90	1.55	39.40		
	02	1	49		1.59	40.46	3.13	79.50	1.16	29.36	1.77	44.96		
		2	50		1.59	40.46	4.13	104.90	1.16	29.36	1.77	44.96		
	03	1	51		1.59	40.46	3.13	79.50	1.16	29.36	1.77	44.96		
		2	52		1.59	40.46	4.13	104.90	1.16	29.36	1.77	44.96		
	04	1	53*		1.59	40.46	3.88	98.55	1.38	34.93	2.11	53.67		
		2	54*		1.59	40.46	4.88	123.95	1.38	34.93	2.11	53.67		
	05	1	130		1.59	40.46	3.13	79.50	1.03	26.09	1.33	33.83		
		2	131		1.59	40.46	4.13	104.90	1.03	26.09	1.33	33.83		
	06	1	144		1.59	40.46	3.13	79.50	1.38	34.93	2.11	53.67		
		2	145		1.59	40.46	4.13	104.90	1.38	34.93	2.11	53.67		
	28	01	1		55	28	1.97	50.01	3.13	79.50	1.06	26.90	1.55	39.40
			2		56		1.97	50.01	4.13	104.90	1.06	26.90	1.55	39.40
02		1	57	1.97	50.01		3.13	79.50	1.16	29.36	1.77	44.96		
		2	58	1.97	50.01		4.13	104.90	1.16	29.36	1.77	44.96		
03		1	59	1.97	50.01		3.13	79.50	1.38	34.93	2.11	53.67		
		2	60	1.97	50.01		4.13	104.90	1.38	34.93	2.11	53.67		
04		1	61	1.97	50.01		3.13	79.50	1.50	38.10	23.63	600.20		
		2	62	1.97	50.01		4.13	104.90	1.50	38.10	2.36	60.02		
32	01	1	63	32	2.22	56.36	3.13	79.50	1.16	29.36	1.77	44.96		
		2	64		2.22	56.36	4.13	104.90	1.16	29.36	1.77	44.96		
	02	1	65		2.22	56.36	3.13	79.50	1.38	34.93	2.11	53.67		
		2	66		2.22	56.36	4.13	104.90	1.38	34.93	2.11	53.67		
	03	1	67		2.22	56.36	3.13	79.50	1.50	38.10	2.36	60.02		
		2	68		2.22	56.36	4.13	104.90	1.50	38.10	2.36	60.02		
	04	1	69		2.22	56.36	3.13	79.50	1.78	45.24	2.77	70.36		
		2	70		2.22	56.36	4.13	104.90	1.78	45.24	2.77	70.36		
36	01	1	71	36	2.47	62.71	4.13	104.90	1.38	34.93	2.11	53.67		
		2	72		2.47	62.71	5.13	130.30	1.38	34.93	2.11	53.67		
	02	1	73		2.47	62.71	4.13	104.90	1.50	38.10	2.36	60.02		
		2	74		2.47	62.71	5.13	130.30	1.50	38.10	2.36	60.02		
	03	1	75		2.47	62.71	4.13	104.90	1.78	45.24	2.77	70.36		
		2	76		2.47	62.71	5.13	130.30	1.78	45.24	2.77	70.36		
	04	1	77*		2.47	62.71	5.01	127.25	1.83	46.48	3.02	76.71		
		2	78*		2.47	62.71	6.01	152.65	1.83	46.48	3.02	76.71		
	05	1	132		2.47	62.71	4.13	104.90	1.06	26.90	1.55	39.40		
		2	133		2.47	62.71	5.13	130.30	1.06	26.90	1.55	39.40		
	06	1	146		2.47	62.71	4.13	104.90	1.83	46.48	3.02	76.71		
		2	147		2.47	62.71	5.13	130.30	1.83	46.48	3.02	76.71		
	07	1	148		2.47	62.71	4.13	104.90	1.16	29.36	1.77	44.96		
		2	149		2.47	62.71	5.13	130.30	1.16	29.36	1.77	44.96		

Table Continued



Connector Group - J

Straight

TABLE - A														
AMPHENOL PART NUMBER DESIGNATOR			MIL PART NUMBER DESIGNATOR	CONNECTOR SHELL SIZE	A DIA. (MAX)		B (MAX)		C (REF)		G (MAX)			
SHELL SIZE	ENTRY SIZE	LENGTH	DASH NO		INCH	MM	INCH	MM	INCH	MM	INCH	MM		
40	01	1	79	40	2.72	69.06	4.13	104.90	1.38	34.93	2.11	53.67		
		2	80		2.72	69.06	5.13	130.30	1.38	34.93	2.11	53.67		
	02	1	81		2.72	69.06	4.13	104.90	1.50	38.10	2.36	60.02		
		2	82		2.72	69.06	5.13	130.30	1.50	38.10	2.36	60.02		
	03	1	83		2.72	69.06	4.13	104.90	1.78	45.24	2.77	70.36		
		2	84		2.72	69.06	5.13	130.30	1.78	45.24	2.77	70.36		
	04	1	85		2.72	69.06	4.13	104.90	1.83	46.48	3.02	76.71		
		2	86		2.72	69.06	5.13	130.30	1.83	46.48	3.02	76.71		
	05	1	134		2.72	69.06	4.13	104.90	1.06	26.90	1.55	39.40		
		2	135		2.72	69.06	5.13	130.30	1.06	26.90	1.55	39.40		
	06	1	156		2.72	69.06	4.13	104.90	1.16	29.36	1.77	44.96		
		2	157		2.72	69.06	5.13	130.30	1.16	29.36	1.77	44.96		
	44	01	1		87	44	2.97	75.41	4.13	104.90	1.38	34.93	2.11	53.67
			2		88		2.97	75.41	5.13	130.30	1.38	34.93	2.11	53.67
02		1	89	2.97	75.41		4.13	104.90	1.50	38.10	2.36	60.02		
		2	90	2.97	75.41		5.13	130.30	1.50	38.10	2.36	60.02		
03		1	91	2.97	75.41		4.13	104.90	1.78	45.24	2.77	70.36		
		2	92	2.97	75.41		5.13	130.30	1.78	45.24	2.77	70.36		
04		1	93	2.97	75.41		4.13	104.90	1.83	46.48	3.02	76.71		
		2	94	2.97	75.41		5.13	130.30	1.83	46.48	3.02	76.71		
05		1	154	2.97	75.41		4.13	104.90	1.16	29.36	1.77	44.96		
		2	155	2.97	75.41		5.13	130.30	1.16	29.36	1.77	44.96		
48	01	1	95	48	3.22	81.76	4.13	104.90	1.38	34.93	2.11	53.67		
		2	96		3.22	81.76	5.13	130.30	1.38	34.93	2.11	53.67		
	02	1	97		3.22	81.76	4.13	104.90	1.50	38.10	2.36	60.02		
		2	98		3.22	81.76	5.13	130.30	1.50	38.10	2.36	60.02		
	03	1	99		3.22	81.76	4.13	104.90	1.78	45.24	2.77	70.36		
		2	100		3.22	81.76	5.13	130.30	1.78	45.24	2.77	70.36		
	04	1	101		3.22	81.76	4.13	104.90	1.83	46.48	3.02	76.71		
		2	102		3.22	81.76	5.13	130.30	1.83	46.48	3.02	76.71		

(*) ----- DENOTES STYLE 2

Table Continued

Connector Group - J

Straight

TABLE - A										
AMPHENOL PART NUMBER DESIGNATOR			MIL PART NUMBER DESIGNATOR	CONNECTOR SHELL SIZE	CABLE RANGE					
SHELL SIZE	ENTRY SIZE	LENGTH	DASH NO		MIN		MAX			
					INCH	MM	INCH	MM		
08	01	1	5	8	0.13	3.18	0.25	6.35		
		2	6		0.13	3.18	0.25	6.35		
	02	1	7*		0.25	6.35	0.44	11.10		
		2	8*		0.25	6.35	0.44	11.10		
10	01	1	9		10	0.13	3.18	0.31	7.92	
		2	10			0.13	3.18	0.31	7.92	
	02	1	11*			0.25	6.35	0.44	11.10	
		2	12*			0.25	6.35	0.44	11.10	
	03	1	136	0.25		6.35	0.38	9.53		
		2	137	0.25		6.35	0.38	9.53		
12	01	1	13	7/12		0.25	6.35	0.44	11.10	
		2	14			0.25	6.35	0.44	11.10	
	02	1	15*			0.35	8.89	0.63	15.88	
		2	16*			0.35	8.89	0.63	15.88	
	03	1	111			0.35	8.89	0.50	12.70	
		2	114			0.13	3.18	0.31	7.92	
	04	1	115		0.13	3.18	0.31	7.92		
		2	115		0.13	3.18	0.31	7.92		
	05	1	138		0.35	8.89	0.50	12.70		
		2	139		0.35	8.89	0.50	12.70		
14	01	1	17		12/14	0.35	8.89	0.58	14.61	
		2	18			0.35	8.89	0.58	14.61	
	02	1	19*			0.50	12.70	0.75	19.05	
		2	20*			0.50	12.70	0.75	19.05	
	03	1	116			0.25	6.35	0.44	11.10	
		2	117			0.25	6.35	0.44	11.10	
	04	1	150			0.13	3.18	0.31	7.92	
		2	151			0.13	3.18	0.31	7.92	
16	01	1	21			19/16	0.50	12.70	0.70	17.78
		2	22				0.50	12.70	0.70	17.78
	02	1	23*	0.63			15.88	0.94	23.80	
		2	24*	0.63			15.88	0.94	23.80	
	03	1	112	0.25			6.35	0.44	11.10	
		2	113	0.25			6.35	0.44	11.10	
	04	1	118	0.35			8.89	0.63	15.88	
		2	119	0.35			8.89	0.63	15.88	
	05	1	152	0.13	3.18		0.31	7.92		
		2	153	0.13	3.18		0.31	7.92		
18	01	1	25	27/18	0.35		8.89	0.63	15.88	
		2	26		0.35		8.89	0.63	15.88	
	02	1	27		0.50		12.70	0.75	19.05	
		2	28		0.50		12.70	0.75	19.05	
	03	1	29*		0.63		15.88	0.94	23.80	
		2	30*		0.63		15.88	0.94	23.80	
	04	1	120		0.13		3.18	0.31	7.92	
		2	121		0.13		3.18	0.31	7.92	
	05	1	122		0.25		6.35	0.44	11.10	
		2	123		0.25		6.35	0.44	11.10	
20	01	1	31		37/20	0.35	8.89	0.63	15.88	
		2	32			0.35	8.89	0.63	15.88	
	02	1	33			0.50	12.70	0.75	19.05	
		2	34			0.50	12.70	0.75	19.05	
	03	1	35*			0.63	15.88	0.94	23.80	
		2	36*			0.63	15.88	0.94	23.80	
	04	1	37*			0.88	22.23	1.25	31.75	
		2	38*			0.88	22.23	1.25	31.75	

Table Continued



TABLE - A									
AMPHENOL PART NUMBER DESIGNATOR			MIL PART NUMBER DESIGNATOR	CONNECTOR SHELL SIZE	CABLE RANGE				
SHELL SIZE	ENTRY SIZE	LENGTH	DASH NO		MIN		MAX		
					INCH	MM	INCH	MM	
20	05	1	124	37/20	0.25	6.35	0.44	11.10	
		2	125		0.25	6.35	0.44	11.10	
	06	1	140		0.63	15.88	0.90	22.96	
		2	141		0.63	15.88	0.90	22.96	
22	01	1	39		22	0.35	8.89	0.63	15.88
		2	40			0.35	8.89	0.63	15.88
	02	1	41			0.50	12.70	0.75	19.05
		2	42			0.50	12.70	0.75	19.05
	03	1	43	0.63		15.88	0.94	23.80	
		2	44	0.63		15.88	0.94	23.80	
	04	1	45*	0.88		22.23	1.25	31.75	
		2	46*	0.88		22.23	1.25	31.75	
	05	1	126	0.13		3.18	0.31	7.92	
		2	127	0.13		3.18	0.31	7.92	
	06	1	128	0.25		6.35	0.44	11.10	
		2	129	0.25		6.35	0.44	11.10	
	07	1	142	0.88		22.23	1.03	26.14	
		2	143	0.88		22.23	1.03	26.14	
24	01	1	47	24	0.50	12.70	0.75	19.05	
		2	48		0.50	12.70	0.75	19.05	
	02	1	49		0.63	15.88	0.81	20.62	
		2	50		0.63	15.88	0.81	20.62	
	03	1	51		0.63	15.88	0.94	23.80	
		2	52		0.63	15.88	0.94	23.80	
	04	1	53*		0.88	22.23	1.25	31.75	
		2	54*		0.88	22.23	1.25	31.75	
	05	1	130		0.35	8.89	0.63	15.88	
		2	131		0.35	8.89	0.63	15.88	
	06	1	144		0.88	22.23	1.14	29.06	
		2	145		0.88	22.23	1.14	29.06	
28	01	1	55	28	0.50	12.70	0.75	19.05	
		2	56		0.50	12.70	0.75	19.05	
	02	1	57		0.63	15.88	0.94	23.80	
		2	58		0.63	15.88	0.94	23.80	
	03	1	59		0.88	22.23	1.25	31.75	
		2	60		0.88	22.23	1.25	31.75	
	04	1	61		1.00	25.40	1.38	34.93	
		2	62		1.00	25.40	1.38	34.93	
32	01	1	63	32	0.63	15.88	0.94	23.80	
		2	64		0.63	15.88	0.94	23.80	
	02	1	65		0.88	22.23	1.25	31.75	
		2	66		0.88	22.23	1.25	31.75	
	03	1	67		1.00	25.40	1.38	34.93	
		2	68		1.00	25.40	1.38	34.93	
	04	1	69		1.25	31.75	1.63	41.28	
		2	70		1.25	31.75	1.63	41.28	
36	01	1	71	36	0.88	22.23	1.25	31.75	
		2	72		0.88	22.23	1.25	31.75	
	02	1	73		1.00	25.40	1.38	34.93	
		2	74		1.00	25.40	1.38	34.93	
	03	1	75		1.25	31.75	1.63	41.28	
		2	76		1.25	31.75	1.63	41.28	
	04	1	77*		1.44	36.50	1.88	47.63	
		2	78*		1.44	36.50	1.88	47.63	

Table Continued

Connector Group - J

Straight

TABLE - A								
AMPHENOL PART NUMBER DESIGNATOR			MIL PART NUMBER DESIGNATOR	CONNECTOR SHELL SIZE	CABLE RANGE			
SHELL SIZE	ENTRY SIZE	LENGTH	DASH NO		MIN		MAX	
					INCH	MM	INCH	MM
36	05	1	132	36	0.50	12.70	0.75	19.05
		2	133		0.50	12.70	0.75	19.05
	06	1	146		1.44	36.50	1.84	46.74
		2	147		1.44	36.50	1.84	46.74
	07	1	148		0.63	15.88	0.94	23.80
		2	149		0.63	15.88	0.94	23.80
40	01	1	79	40	0.88	22.23	1.25	31.75
		2	80		0.88	22.23	1.25	31.75
	02	1	81		1.00	25.40	1.38	34.93
		2	82		1.00	25.40	1.38	34.93
	03	1	83		1.25	31.75	1.63	41.28
		2	84		1.25	31.75	1.63	41.28
	04	1	85		1.44	36.50	1.88	47.63
		2	86		1.44	36.50	1.88	47.63
	05	1	134		0.50	12.70	0.75	19.05
		2	135		0.50	12.70	0.75	19.05
	06	1	156		0.63	15.88	0.94	23.80
		2	157		0.63	15.88	0.94	23.80
44	01	1	87	44	0.88	22.23	1.25	31.75
		2	88		0.88	22.23	1.25	31.75
	02	1	89		1.00	25.40	1.38	34.93
		2	90		1.00	25.40	1.38	34.93
	03	1	91		1.25	31.75	1.63	41.28
		2	92		1.25	31.75	1.63	41.28
	04	1	93		1.44	36.50	1.88	47.63
		2	94		1.44	36.50	1.88	47.63
	05	1	154		0.63	15.88	0.94	23.80
		2	155		0.63	15.88	0.94	23.80
48	01	1	95	48	0.88	22.23	1.25	31.75
		2	96		0.88	22.23	1.25	31.75
	02	1	97		1.00	25.40	1.38	34.93
		2	98		1.00	25.40	1.38	34.93
	03	1	99		1.25	31.75	1.63	41.28
		2	100		1.25	31.75	1.63	41.28
	04	1	101		1.44	36.50	1.88	47.63
		2	102		1.44	36.50	1.88	47.63

(*) ----- DENOTES STYLE 2



Connector Group - J

90°, 45°

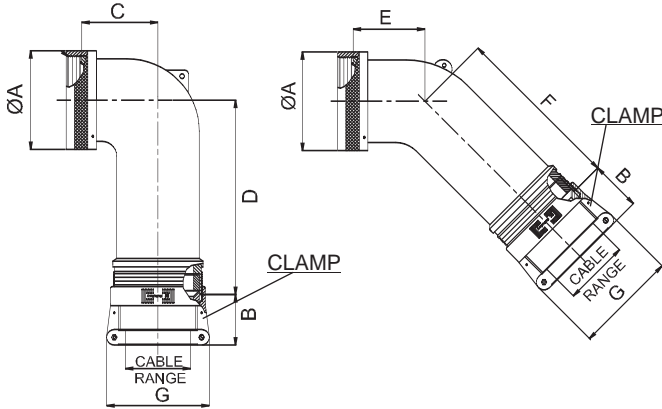

Amphenol Part Number

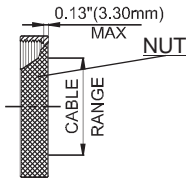
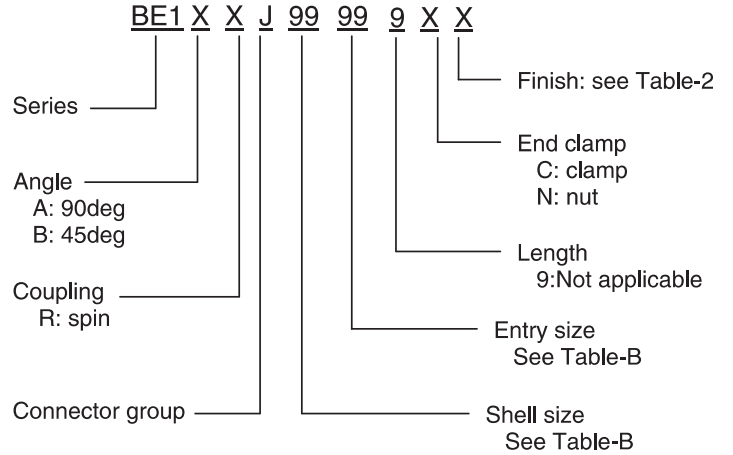

MIL Part Number

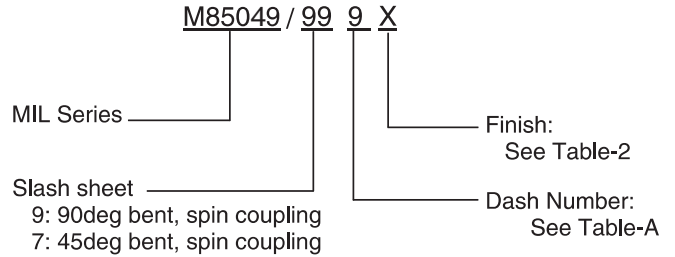

NOTE: * For more cable entry options, contact factory

TABLE - B															
AMPHENOL PART NUMBER DESIGNATOR		MIL PART NUMBER DESIGNATOR	CONNECTOR SHELL SIZE	A DIA. (MAX)		B (REF)		C (MAX)		D (MAX)		E (MAX)		F (MAX)	
SHELL SIZE	ENTRY SIZE	DASH NO		INCH	MM	INCH	MM	INCH	MM	INCH	MM	INCH	MM	INCH	MM
08	01	3	8	0.62	15.67	1.03	26.09	0.67	17.02	1.26	32.00	0.63	16.00	1.25	31.75
	01	4		10	0.73	18.64	1.03	26.09	0.76	19.30	1.98	50.29	0.69	17.53	1.92
10	02	49*	0.73		18.64	1.03	26.09	1.52	38.61	2.00	50.80	1.50	38.10	1.98	50.29
	03	5	0.73		18.64	1.03	26.09	0.76	19.30	1.38	35.05	0.69	17.53	1.31	33.27
12	01	6	7/12	0.86	21.79	1.03	26.09	0.77	19.56	2.00	50.80	0.75	19.05	1.98	50.29
	02	71*		0.86	21.79	1.03	26.09	1.81	45.97	2.16	54.86	1.65	41.91	2.18	55.37
	03	7		0.86	21.79	1.03	26.09	0.77	19.56	2.00	50.80	0.75	19.05	1.98	50.29
	04	8		0.86	21.79	1.03	26.09	0.77	19.56	1.40	35.56	0.75	19.05	1.98	50.29
14	01	9	12/14	0.98	24.99	1.03	26.09	0.87	22.10	2.07	52.58	0.81	20.57	2.07	52.58
	02	10		0.98	24.99	1.03	26.09	0.87	22.10	1.72	43.69	0.81	20.57	1.72	43.69
	03	50*		0.98	24.99	1.06	26.90	1.89	48.01	2.33	59.18	1.84	46.74	2.37	60.20
	04	74		0.98	24.99	1.03	26.09	0.87	22.10	2.07	52.58	0.81	20.57	2.07	52.58
16	01	11	19/16	1.11	28.24	1.03	26.09	1.05	26.67	2.16	54.86	0.91	23.11	2.18	55.37
	02	12		1.11	28.24	1.06	26.90	1.05	26.67	1.81	45.97	0.91	23.11	1.82	46.23
	03	40		1.11	28.24	1.03	26.09	1.05	26.67	2.16	54.86	0.91	23.11	2.18	55.37
	04	51*		1.11	28.24	1.16	29.36	2.04	51.82	2.44	61.98	1.94	49.28	2.52	64.01
	05	75		1.11	28.24	1.03	26.09	1.05	26.67	2.16	54.86	0.91	23.11	2.18	55.37

Table Continued

Connector Group - J

90°, 45°

TABLE - B															
AMPHENOL PART NUMBER DESIGNATOR		MIL PART NUMBER DESIGNATOR	CONNECTOR SHELL SIZE	A DIA. (MAX)		B (REF)		C (MAX)		D (MAX)		E (MAX)		F (MAX)	
SHELL SIZE	ENTRY SIZE	DASH NO		INCH	MM	INCH	MM	INCH	MM	INCH	MM	INCH	MM	INCH	MM
18	01	13	27/18	1.22	30.94	1.03	26.09	1.14	28.96	2.33	59.18	1.09	27.69	2.37	60.20
	02	14		1.22	30.94	1.16	29.36	1.14	28.96	1.98	50.29	1.09	27.69	2.00	50.80
	03	41		1.22	30.94	1.03	26.09	1.14	28.96	2.33	59.18	1.09	27.69	2.37	60.20
	04	42		1.22	30.94	1.03	26.09	1.14	28.96	2.33	59.18	1.09	27.69	2.37	60.20
	05	52		1.22	30.94	1.06	26.90	1.14	28.96	2.33	59.18	1.09	27.69	2.37	60.20
	06	72*		1.22	30.94	1.16	29.36	2.05	52.07	2.44	61.98	1.94	49.28	2.52	64.01
20	01	15	37/20	1.35	34.16	1.03	26.09	1.14	28.96	2.33	59.18	1.09	27.69	2.37	60.20
	02	16		1.35	34.16	1.16	29.36	1.14	28.96	1.98	50.29	1.09	27.69	2.00	50.80
	03	43		1.35	34.16	1.03	26.09	1.14	28.96	2.33	59.18	1.09	27.69	2.37	60.20
	04	54		1.35	34.16	1.06	26.90	1.14	28.96	2.33	59.18	1.09	27.69	2.37	60.20
	05	55		1.35	34.16	1.38	34.93	2.14	54.36	2.61	66.29	2.06	52.32	2.57	65.28
	06	72*		1.47	37.29	1.06	26.90	1.29	32.77	2.44	61.98	1.19	30.23	2.52	64.01
22	01	17	22	1.47	37.29	1.38	34.93	1.29	32.77	2.09	53.09	1.19	30.23	2.16	54.86
	02	18		1.47	37.29	1.03	26.09	1.29	32.77	2.44	61.98	1.19	30.23	2.52	64.01
	03	44		1.47	37.29	1.03	26.09	1.29	32.77	2.44	61.98	1.19	30.23	2.52	64.01
	04	45		1.47	37.29	1.03	26.09	1.29	32.77	2.44	61.98	1.19	30.23	2.52	64.01
	05	56		1.47	37.29	1.03	26.09	1.29	32.77	2.44	61.98	1.19	30.23	2.52	64.01
	06	57		1.47	37.29	1.16	29.36	1.29	32.77	2.44	61.98	1.19	30.23	2.52	64.01
	07	58*		1.47	37.29	1.38	34.93	2.14	54.36	2.61	66.29	2.06	52.32	2.57	65.28
24	01	19	24	1.59	40.46	1.06	26.90	1.29	32.77	2.44	61.98	1.19	30.23	2.52	64.01
	02	20		1.59	40.46	1.38	34.93	1.29	32.77	2.09	53.09	1.19	30.23	2.16	54.86
	03	46		1.59	40.46	1.03	26.09	1.29	32.77	2.44	61.98	1.19	30.23	2.52	64.01
	04	59		1.59	40.46	1.16	29.36	1.29	32.77	2.44	61.98	1.19	30.23	2.52	64.01
	05	73*		1.59	40.46	1.38	34.93	2.15	54.61	2.61	66.29	2.06	52.32	2.57	65.28
28	01	21	28	1.97	50.01	1.16	29.36	1.39	35.31	2.61	66.29	1.31	33.27	2.57	65.28
	02	22		1.97	50.01	1.50	38.10	1.39	35.31	2.26	57.40	1.31	33.27	2.22	56.39
	03	60		1.97	50.01	1.06	26.90	1.39	35.31	2.61	66.29	1.31	33.27	2.57	65.28
	04	61		1.97	50.01	1.38	34.93	1.39	35.31	2.61	66.29	1.31	33.27	2.57	65.28
32	01	23	32	2.22	56.36	1.16	29.36	1.74	44.20	2.86	72.64	1.38	35.05	2.67	67.82
	02	24		2.22	56.36	1.38	34.93	1.74	44.20	2.86	72.64	1.38	35.05	2.67	67.82
	03	25		2.22	56.36	1.78	45.24	1.74	44.20	2.51	63.75	1.38	35.05	2.32	58.93
	04	62		2.22	56.36	1.50	38.10	1.74	44.20	2.86	72.64	1.38	35.05	2.67	67.82
36	01	26	36	2.47	62.71	1.16	29.36	1.94	49.28	2.83	71.88	1.41	35.81	2.76	70.10
	02	27		2.47	62.71	1.50	38.10	1.94	49.28	2.83	71.88	1.41	35.81	2.76	70.10
	03	28		2.47	62.71	1.83	46.48	1.94	49.28	2.48	62.99	1.41	35.81	2.41	61.21
	04	47		2.47	62.71	1.06	26.90	1.94	49.28	2.83	71.88	1.41	35.81	2.76	70.10
	05	63		2.47	62.71	1.38	34.93	1.94	49.28	2.83	71.88	1.41	35.81	2.76	70.10
	06	64		2.47	62.71	1.78	45.24	1.94	49.28	2.83	71.88	1.41	35.81	2.76	70.10
40	01	29	40	2.72	69.06	1.16	29.36	2.69	68.33	2.83	71.88	2.16	54.86	2.76	70.10
	02	30		2.72	69.06	1.50	38.10	2.69	68.33	2.83	71.88	2.16	54.86	2.76	70.10
	03	31		2.72	69.06	1.83	46.48	2.69	68.33	2.48	62.99	2.16	54.86	2.41	61.21
	04	48		2.72	69.06	1.06	26.90	1.94	49.28	2.83	71.88	2.16	54.86	2.76	70.10
	05	65		2.72	69.06	1.38	34.93	2.69	68.33	2.83	71.88	2.16	54.86	2.76	70.10
	06	66		2.72	69.06	1.78	45.24	2.69	68.33	2.83	71.88	2.16	54.86	2.76	70.10
44	01	32	44	2.97	75.41	1.16	29.36	2.69	68.33	2.83	71.88	2.16	54.86	2.76	70.10
	02	33		2.97	75.41	1.50	38.10	2.69	68.33	2.83	71.88	2.16	54.86	2.76	70.10
	03	34		2.97	75.41	1.83	46.48	2.69	68.33	2.48	62.99	2.16	54.86	2.41	61.21
	04	67		2.97	75.41	1.38	34.93	2.69	68.33	2.83	71.88	2.16	54.86	2.76	70.10
	05	68		2.97	75.41	1.78	45.24	2.69	68.33	2.83	71.88	2.16	54.86	2.76	70.10
48	01	35	48	3.22	81.76	1.16	29.36	2.69	68.33	2.83	71.88	2.16	54.86	2.76	70.10
	02	36		3.22	81.76	1.50	38.10	2.69	68.33	2.83	71.88	2.16	54.86	2.76	70.10
	03	37		3.22	81.76	1.83	46.48	2.69	68.33	2.48	62.99	2.16	54.86	2.41	61.21
	04	69		3.22	81.76	1.38	34.93	2.69	68.33	2.83	71.88	2.16	54.86	2.76	70.10
	05	70		3.22	81.76	1.78	45.24	2.69	68.33	2.83	71.88	2.16	54.86	2.76	70.10

(*) ----- DENOTES STYLE 2

Table Continued

Connector Group - J

90°, 45°

TABLE - B									
AMPHENOL PART NUMBER DESIGNATOR		MIL PART NUMBER DESIGNATOR	CONNECTOR SHELL SIZE	G (MAX)		CABLE RANGE			
SHELL SIZE	ENTRY SIZE	DASH NO		INCH	MM	MIN		MAX	
						INCH	MM	INCH	MM
08	01	3	8	0.96	24.31	0.13	3.18	0.25	6.35
10	01	4	10	0.96	24.31	0.13	3.18	0.31	7.92
	02	49*		1.15	29.08	0.25	6.35	0.44	11.10
	03	5		1.15	29.08	0.25	6.35	0.38	9.53
12	01	6	7/12	0.96	24.31	0.13	3.18	0.31	7.92
	02	71*		1.33	33.83	0.35	8.89	0.63	15.88
	03	7		1.15	29.08	0.25	6.35	0.44	11.10
	04	8		1.33	33.83	0.35	8.89	0.50	12.70
14	01	9	12/14	1.15	29.08	0.25	6.35	0.44	11.10
	02	10		1.33	33.83	0.35	8.89	0.58	14.61
	03	50*		1.55	39.40	0.50	12.70	0.75	19.05
	04	74		0.96	24.31	0.13	3.18	0.31	7.92
16	01	11	19/16	1.15	29.08	0.25	6.35	0.44	11.10
	02	12		1.55	39.40	0.50	12.70	0.70	17.78
	03	40		1.33	33.83	0.35	8.89	0.63	15.88
	04	51*		1.77	44.96	0.63	15.88	0.94	23.80
	05	75		0.96	24.31	0.13	3.18	0.31	7.92
18	01	13	27/18	1.33	33.83	0.35	8.89	0.63	15.88
	02	14		1.77	44.96	0.63	15.88	0.78	19.79
	03	41		0.96	24.31	0.13	3.18	0.31	7.92
	04	42		1.15	29.08	0.25	6.35	0.44	11.10
	05	52		1.55	39.40	0.50	12.70	0.75	19.05
	06	72*		1.77	44.96	0.63	15.88	0.94	23.80
20	01	15	37/20	1.33	33.83	0.35	8.89	0.63	15.88
	02	16		1.77	44.96	0.63	15.88	0.90	22.96
	03	43		1.15	29.08	0.25	6.35	0.44	11.10
	04	54		1.55	39.40	0.50	12.70	0.75	19.05
	05	55		2.11	53.67	0.88	22.23	1.25	31.75
22	01	17	22	1.55	39.40	0.50	12.70	0.75	19.05
	02	18		2.11	53.67	0.88	22.23	1.03	26.14
	03	44		0.96	24.31	0.13	3.18	0.31	7.92
	04	45		1.15	29.08	0.25	6.35	0.44	11.10
	05	56		1.33	33.83	0.35	8.89	0.63	15.88
	06	57		1.77	44.96	0.63	15.88	0.94	23.80
	07	58*		2.11	53.67	0.88	22.23	1.25	31.75
24	01	19	24	1.55	39.40	0.50	12.70	0.75	19.05
	02	20		2.11	53.67	0.88	22.23	1.14	29.06
	03	46		1.33	33.83	0.35	8.89	0.63	15.88
	04	59		1.77	44.96	0.63	15.88	0.94	23.80
	05	73*		2.12	53.75	0.88	22.23	1.25	31.75
28	01	21	28	1.77	44.96	0.63	15.88	0.94	23.80
	02	22		2.36	60.02	1.00	25.40	1.38	34.93
	03	60		1.55	39.40	0.50	12.70	0.75	19.05
	04	61		2.11	53.67	0.88	22.23	1.25	31.75
32	01	23	32	1.77	44.96	0.63	15.88	0.94	23.80
	02	24		2.11	53.67	0.88	22.23	1.25	31.75
	03	25		2.77	70.36	1.25	31.75	1.63	41.28
	04	62		2.36	60.02	1.00	25.40	1.38	34.93
	05	63		2.36	60.02	1.00	25.40	1.38	34.93
36	01	26	36	1.77	44.96	0.63	15.88	0.94	23.80
	02	27		2.36	60.02	1.00	25.40	1.38	34.93
	03	28		3.02	76.71	1.44	36.50	1.84	46.74
	04	47		1.55	39.40	0.50	12.70	0.75	19.05
	05	63		2.11	53.67	0.88	22.23	1.25	31.75
	06	64		2.77	70.36	1.25	31.75	1.63	41.28

Table Continued

Connector Group - J

90°, 45°

TABLE - B									
AMPHENOL PART NUMBER DESIGNATOR		MIL PART NUMBER DESIGNATOR	CONNECTOR SHELL SIZE	G (MAX)		CABLE RANGE			
SHELL SIZE	ENTRY SIZE	DASH NO				MIN		MAX	
				INCH	MM	INCH	MM	INCH	MM
40	01	29	40	1.77	44.96	0.63	15.88	0.94	23.80
	02	30		2.36	60.02	1.00	25.40	1.38	34.93
	03	31		3.02	76.71	1.44	36.50	1.88	47.63
	04	48		1.55	39.40	0.50	12.70	0.75	19.05
	05	65		2.11	53.67	0.88	22.23	1.25	31.75
	06	66		2.77	70.36	1.25	31.75	1.63	41.28
44	01	32	44	1.77	44.96	0.63	15.88	0.94	23.80
	02	33		2.36	60.02	1.00	25.40	1.38	34.93
	03	34		3.02	76.71	1.44	36.50	1.88	47.63
	04	67		2.11	53.67	0.88	22.23	1.25	31.75
	05	68		2.77	70.36	1.25	31.75	1.63	41.28
48	01	35	48	1.77	44.96	0.63	15.88	0.94	23.80
	02	36		2.36	60.02	1.00	25.40	1.38	34.93
	03	37		3.02	76.71	1.44	36.50	1.88	47.63
	04	69		2.11	53.67	0.88	22.23	1.25	31.75
	05	70		2.77	70.36	1.25	31.75	1.63	41.28

(*) ----- DENOTES STYLE 2



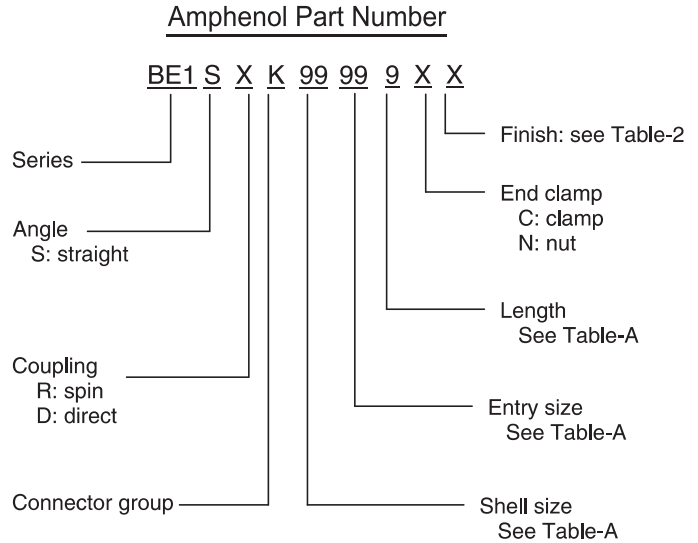
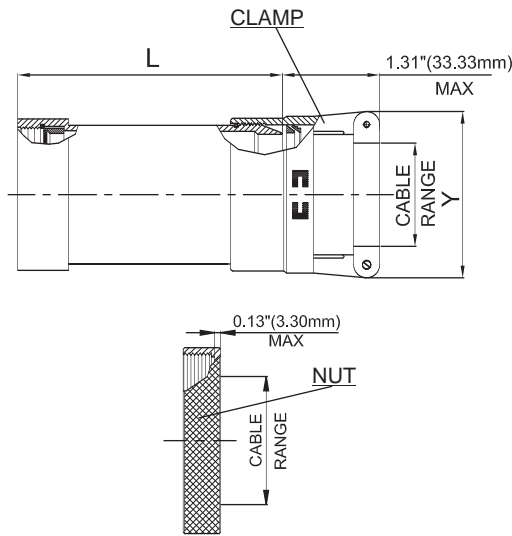

NOTE: * For more cable entry and length options, contact factory

TABLE - A												
AMPHENOL PART NUMBER DESIGNATOR			CONNECTOR SHELL SIZE SE - II / I	CABLE RANGE				L (MAX)		Y (MAX)		
SHELL SIZE	ENTRY SIZE	LENGTH		MIN		MAX		INCH	MM	INCH	MM	
				INCH	MM	INCH	MM					
08	01	1	8 / 9	0.06	1.57	0.13	3.18	1.53	38.86	0.78	19.81	
		2						2.53	64.26			
	02	1		0.13	3.18	0.25	6.35	1.53	38.86			
		2		0.25	6.35	0.38	9.53	2.53	64.26			
10	01	1		10 / 11	0.06	1.57	0.13	3.18	1.53	38.86	0.78	19.81
		2							2.53	64.26		
	02	1			0.13	3.18	0.25	6.35	1.53	38.86		
		2			0.25	6.35	0.38	9.53	2.53	64.26		
	03	1	0.25		6.35	0.38	9.53	1.53	38.86			
		2	0.38		9.53	0.50	12.70	2.53	64.26			
12	01	1	12 / 13	0.13	3.18	0.25	6.35	1.53	38.86	0.97	24.64	
		2						2.53	64.26			
	02	1		0.25	6.35	0.38	9.53	1.53	38.86			
		2		0.38	9.53	0.50	12.70	2.53	64.26			
	03	1		0.31	7.92	0.50	12.70	1.53	38.86			
		2		0.50	12.70	0.63	15.88	2.53	64.26			
14	01	1	14 / 15	0.13	3.18	0.25	6.35	1.53	38.86	0.97	24.64	
		2						2.53	64.26			
		3						3.53	89.66			
	02	1		0.25	6.35	0.38	9.53	1.53	38.86			
		2						2.53	64.26			
		3						3.53	89.66			
	03	1		0.31	7.92	0.50	12.70	1.53	38.86			
		2						2.53	64.26			
		3						3.53	89.66			
	04	1		0.44	11.10	0.63	15.88	1.53	38.86			
		2						2.53	64.26			
		3						3.53	89.66			

Table Continued

Connector Group - K

Straight

TABLE - A											
AMPHENOL PART NUMBER DESIGNATOR			CONNECTOR SHELL SIZE SE - II / I	CABLE RANGE				L (MAX)		Y (MAX)	
SHELL SIZE	ENTRY SIZE	LENGTH		MIN		MAX		INCH	MM	INCH	MM
				INCH	MM	INCH	MM				
16	01	1	16 / 17	0.13	3.18	0.25	6.35	1.53	38.86	0.97	24.64
		2						2.53	64.26		
		3						3.53	89.66		
	02	1		0.25	6.35	0.38	9.53	1.53	38.86	1.06	26.92
		2						2.53	64.26		
		3						3.53	89.66		
	03	1		0.31	7.92	0.50	12.70	1.53	38.86	1.16	29.46
		2						2.53	64.26		
		3						3.53	89.66		
	04	1		0.44	11.10	0.63	15.88	1.53	38.86	1.25	31.75
		2						2.53	64.26		
		3						3.53	89.66		
	05	1		0.56	14.27	0.75	19.05	1.53	38.86	1.38	35.05
		2						2.53	64.26		
		3						3.53	89.66		
18	01	1	18 / 19	0.25	6.35	0.38	9.53	1.53	38.86	1.06	26.92
		2						2.53	64.26		
		3						3.53	89.66		
	02	1		0.31	7.92	0.50	12.70	1.53	38.86	1.16	29.46
		2						2.53	64.26		
		3						3.53	89.66		
	03	1		0.44	11.10	0.63	15.88	1.53	38.86	1.25	31.75
		2						2.53	64.26		
		3						3.53	89.66		
	04	1		0.56	14.27	0.75	19.05	1.53	38.86	1.38	35.05
		2						2.53	64.26		
		3						3.53	89.66		
	05	1		0.69	17.45	0.88	22.23	1.53	38.86	1.50	38.10
		2						2.53	64.26		
		3						3.53	89.66		
20	01	1	20 / 21	0.25	6.35	0.38	9.53	1.53	38.86	1.06	26.92
		2						2.53	64.26		
		3						3.53	89.66		
		4						4.53	115.06		
	02	1		0.31	7.92	0.50	12.70	1.53	38.86	1.16	29.46
		2						2.53	64.26		
		3						3.53	89.66		
		4						4.53	115.06		
	03	1		0.44	11.10	0.63	15.88	1.53	38.86	1.25	31.75
		2						2.53	64.26		
		3						3.53	89.66		
		4						4.53	115.06		
	04	1		0.56	14.27	0.75	19.05	1.53	38.86	1.38	35.05
		2						2.53	64.26		
		3						3.53	89.66		
		4						4.53	115.06		
	05	1		0.69	17.45	0.88	22.23	1.53	38.86	1.50	38.10
		2						2.53	64.26		
		3						3.53	89.66		
		4						4.53	115.06		
	06	1		0.81	20.62	1.00	25.40	1.53	38.86	1.63	41.40
		2						2.53	64.26		
		3						3.53	89.66		
		4						4.53	115.06		

Table Continued



TABLE - A											
AMPHENOL PART NUMBER DESIGNATOR			CONNECTOR SHELL SIZE SE - II / I	CABLE RANGE				L (MAX)		Y (MAX)	
SHELL SIZE	ENTRY SIZE	LENGTH		MIN		MAX		INCH	MM	INCH	MM
				INCH	MM	INCH	MM				
22	01	1	22 / 23	0.25	6.35	0.38	9.53	1.53	38.86	1.06	26.92
		2						2.53	64.26		
		3						3.53	89.66		
		4						4.53	115.06		
	02	1		0.31	7.92	0.50	12.70	1.53	38.86	1.16	29.46
		2						2.53	64.26		
		3						3.53	89.66		
		4						4.53	115.06		
	03	1		0.44	11.10	0.63	15.88	1.53	38.86	1.25	31.75
		2						2.53	64.26		
		3						3.53	89.66		
		4						4.53	115.06		
	04	1		0.56	14.27	0.75	19.05	1.53	38.86	1.38	35.05
		2						2.53	64.26		
		3						3.53	89.66		
		4						4.53	115.06		
	05	1		0.69	17.45	0.88	22.23	1.53	38.86	1.50	38.10
		2						2.53	64.26		
		3						3.53	89.66		
		4						4.53	115.06		
	06	1		0.81	20.62	1.00	25.40	1.53	38.86	1.63	41.40
		2						2.53	64.26		
		3						3.53	89.66		
		4						4.53	115.06		
	07	1		0.94	23.80	1.13	28.58	1.53	38.86	1.75	44.45
		2						2.53	64.26		
		3						3.53	89.66		
		4						4.53	115.06		
24	01	1	24 / 25	0.31	7.92	0.50	12.70	1.53	38.86	1.16	29.46
		2						2.53	64.26		
		3						3.53	89.66		
		4						4.53	115.06		
	02	1		0.44	11.10	0.63	15.88	1.53	38.86	1.25	31.75
		2						2.53	64.26		
		3						3.53	89.66		
		4						4.53	115.06		
	03	1		0.56	14.27	0.75	19.05	1.53	38.86	1.38	35.05
		2						2.53	64.26		
		3						3.53	89.66		
		4						4.53	115.06		
	04	1		0.69	17.45	0.88	22.23	1.53	38.86	1.50	38.10
		2						2.53	64.26		
		3						3.53	89.66		
		4						4.53	115.06		
	05	1		0.81	20.62	1.00	25.40	1.53	38.86	1.63	41.40
		2						2.53	64.26		
		3						3.53	89.66		
		4						4.53	115.06		
	06	1		0.94	23.80	1.13	28.58	1.53	38.86	1.75	44.45
		2						2.53	64.26		
		3						3.53	89.66		
		4						4.53	115.06		
	07	1		1.06	26.97	1.25	31.75	1.53	38.86	1.88	47.75
		2						2.53	64.26		
		3						3.53	89.66		
		4						4.53	115.06		

Connector Group - K

90°, 45°

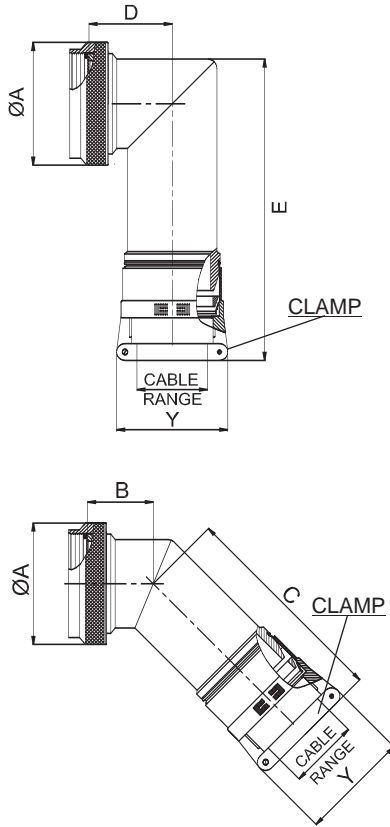

Amphenol Part Number

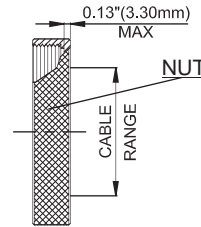
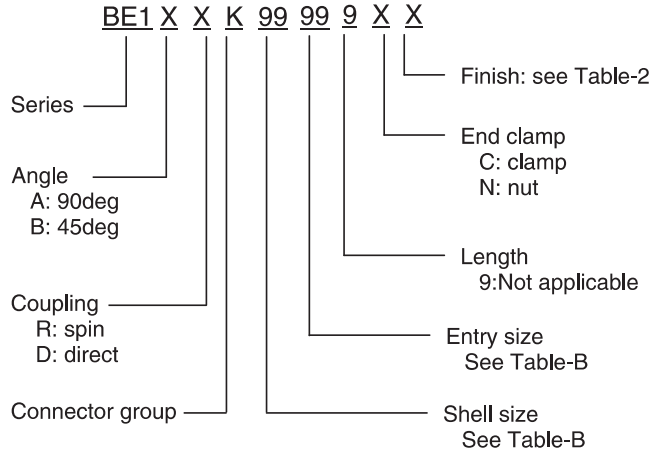

NOTE: * For more cable entry options, contact factory

TABLE - B																			
AMPHENOL PART NUMBER DESIGNATOR	CONNECTOR SHELL SIZE SE - II / I	CABLE RANGE						A DIA. (MAX)		B (MAX)		C (MAX)		D (MAX)		E (MAX)		Y (MAX)	
		MIN		MAX				INCH	MM	INCH	MM	INCH	MM	INCH	MM	INCH	MM	INCH	MM
		INCH	MM	INCH	MM	INCH	MM												
08	01	8 / 9	0.06	1.57	0.13	3.18	0.75	19.05	0.46	11.68	3.15	80.01	0.69	17.53	3.46	87.88	0.78	19.81	
	02		0.13	3.18	0.25	6.35											0.97	24.64	
10	01	10 / 11	0.06	1.57	0.13	3.18	0.85	21.59	0.52	13.21	3.21	81.53	0.78	19.81	3.58	90.93	0.78	19.81	
	02		0.13	3.18	0.25	6.35											0.97	24.64	
	Ø		0.25	6.35	0.38	9.53											1.06	26.92	
12	01	12 / 13	0.13	3.18	0.25	6.35	1.00	25.40	0.58	14.73	3.27	83.06	0.80	20.32	3.60	91.44	0.97	24.64	
	02		0.25	6.35	0.38	9.53											1.06	26.92	
	03		0.31	7.92	0.50	12.70											1.16	29.46	
14	01	14 / 15	0.13	3.18	0.25	6.35	1.15	29.21	0.65	16.51	3.36	85.34	0.88	22.35	3.67	93.22	0.97	24.64	
	02		0.25	6.35	0.38	9.53											1.06	26.92	
	03		0.31	7.92	0.50	12.70											1.16	29.46	
	04		0.44	11.10	0.63	15.88											1.25	31.75	
16	01	16 / 17	0.13	3.18	0.25	6.35	1.25	31.75	0.74	18.80	3.47	88.14	0.93	23.62	3.76	95.50	0.97	24.64	
	02		0.25	6.35	0.38	9.53											1.06	26.92	
	03		0.31	7.92	0.50	12.70											1.16	29.46	
	04		0.44	11.10	0.63	15.88											1.25	31.75	
	05		0.56	14.27	0.75	19.05											1.38	35.05	

Table Continued

Connector Group - K

90°, 45°

TABLE - B																		
AMPHENOL PART NUMBER DESIGNATOR		CONNECTOR SHELL SIZE SE - II / I	CABLE RANGE				A DIA. (MAX)		B (MAX)		C (MAX)		D (MAX)		E (MAX)		Y (MAX)	
SHELL SIZE	ENTRY SIZE		MIN		MAX		INCH	MM	INCH	MM	INCH	MM	INCH	MM	INCH	MM	INCH	MM
			INCH	MM	INCH	MM												
18	01	18 / 19	0.25	6.35	0.38	9.53	1.40	35.56	0.93	23.62	3.66	92.96	1.01	25.65	3.93	99.82	1.06	26.92
	02		0.31	7.92	0.50	12.70											1.16	29.46
	03		0.44	11.10	0.63	15.88											1.25	31.75
	04		0.56	14.27	0.75	19.05											1.38	35.05
	05		0.69	17.45	0.88	22.23											1.50	38.10
20	01	20 / 21	0.25	6.35	0.38	9.53	1.55	39.37	0.93	23.62	3.66	92.96	1.06	26.92	3.93	99.82	1.06	26.92
	02		0.31	7.92	0.50	12.70											1.16	29.46
	03		0.44	11.10	0.63	15.88											1.25	31.75
	04		0.56	14.27	0.75	19.05											1.38	35.05
	05		0.69	17.45	0.88	22.23											1.50	38.10
	06		0.81	20.62	1.00	25.40											1.63	41.40
22	01	22 / 23	0.25	6.35	0.38	9.53	1.65	41.91	1.02	25.91	3.81	96.77	1.17	29.72	4.04	102.62	1.06	26.92
	02		0.31	7.92	0.50	12.70											1.16	29.46
	03		0.44	11.10	0.63	15.88											1.25	31.75
	04		0.56	14.27	0.75	19.05											1.38	35.05
	05		0.69	17.45	0.88	22.23											1.50	38.10
	06		0.81	20.62	1.00	25.40											1.63	41.40
	07		0.94	23.80	1.13	28.58											1.75	44.45
24	01	24 / 25	0.31	7.92	0.50	12.70	1.85	46.99	1.02	25.91	3.81	96.77	1.18	29.97	4.04	102.62	1.16	29.46
	02		0.44	11.10	0.63	15.88											1.25	31.75
	03		0.56	14.27	0.75	19.05											1.38	35.05
	04		0.69	17.45	0.88	22.23											1.50	38.10
	05		0.81	20.62	1.00	25.40											1.63	41.40
	06		0.94	23.80	1.13	28.58											1.75	44.45
	07		1.06	26.97	1.25	31.75											1.88	47.75

Connector Group - L

Straight

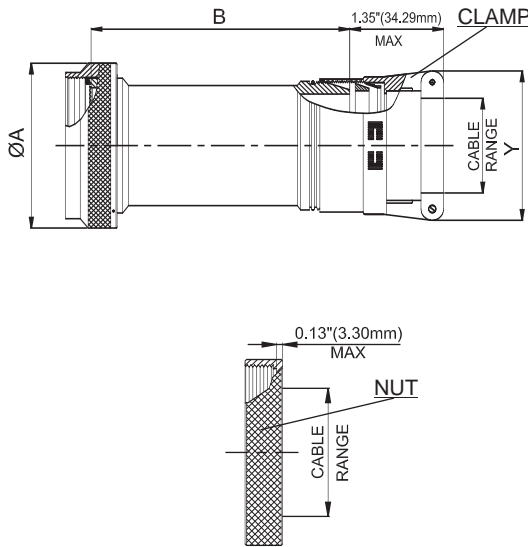

Amphenol Part Number

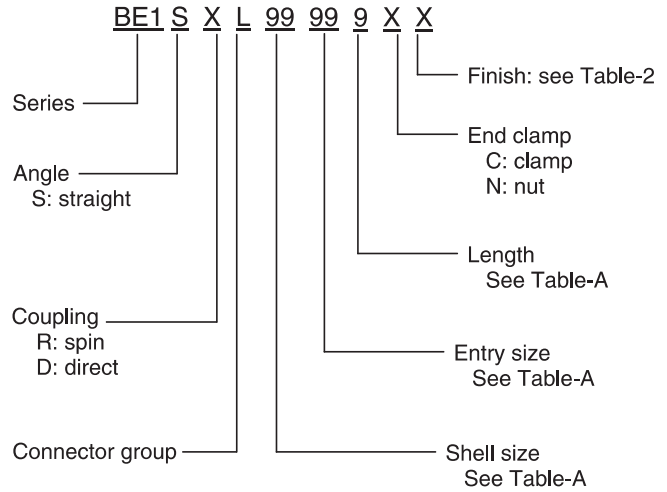

NOTE: * For more cable entry and length options, contact factory

TABLE - A													
AMPHENOL PART NUMBER DESIGNATOR			CONNECTOR SHELL SIZE/CODE (REF.)	CABLE RANGE				A DIA. (MAX)		B (MAX)		Y (MAX)	
SHELL SIZE	ENTRY SIZE	LENGTH		MIN		MAX		INCH	MM	INCH	MM	INCH	MM
				INCH	MM	INCH	MM						
08	01	1	09 / A	0.06	1.57	0.13	3.18	0.75	19.05	1.53	38.86	0.80	20.32
		2		2.53	64.26								
	02	1		0.13	3.18	0.25	6.35			1.53	38.86		
		2		2.53	64.26								
10	01	1	11 / B	0.06	1.57	0.13	3.18	0.85	21.59	1.53	38.86	1.00	25.40
		2		2.53	64.26								
	02	1		0.13	3.18	0.25	6.35			1.53	38.86		
		2		2.53	64.26								
	03	1		0.25	6.35	0.38	9.53			1.53	38.86		
		2		2.53	64.26								
12	01	1	13 / C	0.13	3.18	0.25	6.35	1.00	25.40	1.53	38.86	1.00	25.40
		2		2.53	64.26								
	02	1		0.25	6.35	0.38	9.53			1.53	38.86		
		2		2.53	64.26								
	03	1		0.31	7.92	0.50	12.70			1.53	38.86		
		2		2.53	64.26								
14	01	1	15 / D	0.13	3.18	0.25	6.35	1.10	27.94	1.53	38.86	1.00	25.40
		2								2.53	64.26		
		3								3.53	89.66		
	02	1		0.25	6.35	0.38	9.53			1.53	38.86		
		2								2.53	64.26		
		3								3.53	89.66		
	03	1		0.31	7.92	0.50	12.70			1.53	38.86		
		2								2.53	64.26		
		3								3.53	89.66		
	04	1		0.44	11.10	0.63	15.88			1.53	38.86		
		2								2.53	64.26		
		3								3.53	89.66		

Table Continued

TABLE - A															
AMPHENOL PART NUMBER DESIGNATOR			CONNECTOR SHELL SIZE/CODE (REF.)	CABLE RANGE				A DIA. (MAX)		B (MAX)		Y (MAX)			
SHELL SIZE	ENTRY SIZE	LENGTH		MIN		MAX		INCH	MM	INCH	MM	INCH	MM		
				INCH	MM	INCH	MM								
16	01	1	17 / E	0.13	3.18	0.25	6.35	1.25	31.75	1.53	38.86	1.00	25.40		
		2								2.53	64.26				
		3								3.53	89.66				
	02	1		0.25	6.35	0.38	9.53			1.53	38.86	1.10	27.94		
		2												2.53	64.26
		3												3.53	89.66
	03	1		0.31	7.92	0.50	12.70			1.53	38.86	1.20	30.48		
		2												2.53	64.26
		3												3.53	89.66
	04	1		0.44	11.10	0.63	15.88			1.53	38.86	1.25	31.75		
		2												2.53	64.26
		3												3.53	89.66
05	1	0.56	14.27	0.75	19.05	1.53	38.86	1.40	35.56						
	2									2.53	64.26				
	3									3.53	89.66				
18	01	1	19 / F	0.25	6.35	0.38	9.53	1.40	35.56	1.53	38.86	1.10	27.94		
		2								2.53	64.26				
		3								3.53	89.66				
	02	1		0.31	7.92	0.50	12.70			1.53	38.86	1.20	30.48		
		2												2.53	64.26
		3												3.53	89.66
	03	1		0.44	11.10	0.63	15.88			1.53	38.86	1.25	31.75		
		2												2.53	64.26
		3												3.53	89.66
	04	1		0.56	14.27	0.75	19.05			1.53	38.86	1.40	35.56		
		2												2.53	64.26
		3												3.53	89.66
05	1	0.69	17.45	0.88	22.23	1.53	38.86	1.50	38.10						
	2									2.53	64.26				
	3									3.53	89.66				
20	01	1	21 / G	0.25	6.35	0.38	9.53	1.50	38.10	1.53	38.86	1.10	27.94		
		2								2.53	64.26				
		3								3.53	89.66				
		4								4.53	115.06				
	02	1		0.31	7.92	0.50	12.70			1.53	38.86	1.20	30.48		
		2												2.53	64.26
		3												3.53	89.66
		4												4.53	115.06
	03	1		0.44	11.10	0.63	15.88			1.53	38.86	1.25	31.75		
		2												2.53	64.26
		3												3.53	89.66
		4												4.53	115.06
20	04	1	21 / G	0.56	14.27	0.75	19.05	1.50	38.1	1.53	38.86	1.40	35.56		
		2								2.53	64.26				
		3								3.53	89.66				
		4								4.53	115.06				
	05	1		0.69	17.45	0.88	22.23			1.53	38.86	1.50	38.10		
		2												2.53	64.26
		3												3.53	89.66
		4												4.53	115.06
	06	1		0.81	20.62	1.00	25.40			1.53	38.86	1.65	41.91		
		2												2.53	64.26
		3												3.53	89.66
		4												4.53	115.06

Table Continued

Connector Group - L

Straight

TABLE - A													
AMPHENOL PART NUMBER DESIGNATOR			CONNECTOR SHELL SIZE/CODE (REF.)	CABLE RANGE				A DIA. (MAX)		B (MAX)		Y (MAX)	
SHELL SIZE	ENTRY SIZE	LENGTH		MIN		MAX		INCH	MM	INCH	MM	INCH	MM
				INCH	MM	INCH	MM						
22	01	1	23 / H	0.25	6.35	0.38	9.53	1.65	41.91	1.53	38.86	1.10	27.94
		2								2.53	64.26		
		3								3.53	89.66		
		4								4.53	115.06		
	02	1		0.31	7.92	0.50	12.70			1.53	38.86	1.20	30.48
		2								2.53	64.26		
		3								3.53	89.66		
		4								4.53	115.06		
	03	1		0.44	11.10	0.63	15.88			1.53	38.86	1.25	31.75
		2								2.53	64.26		
		3								3.53	89.66		
		4								4.53	115.06		
	04	1		0.56	14.27	0.75	19.05			1.53	38.86	1.40	35.56
		2								2.53	64.26		
		3								3.53	89.66		
		4								4.53	115.06		
	05	1		0.69	17.45	0.88	22.23			1.53	38.86	1.50	38.10
		2								2.53	64.26		
		3								3.53	89.66		
		4								4.53	115.06		
	06	1		0.81	20.62	1.00	25.40			1.53	38.86	1.65	41.91
		2								2.53	64.26		
		3								3.53	89.66		
		4								4.53	115.06		
	07	1		0.94	23.80	1.13	28.58			1.53	38.86	1.75	44.45
		2								2.53	64.26		
		3								3.53	89.66		
		4								4.53	115.06		
24	01	1	25 / J	0.31	7.92	0.50	12.70	1.75	44.45	1.53	38.86	1.20	30.48
		2								2.53	64.26		
		3								3.53	89.66		
		4								4.53	115.06		
	02	1		0.44	11.10	0.63	15.88			1.53	38.86	1.25	31.75
		2								2.53	64.26		
		3								3.53	89.66		
		4								4.53	115.06		
	03	1		0.56	14.27	0.75	19.05			1.53	38.86	1.40	35.56
		2								2.53	64.26		
		3								3.53	89.66		
		4								4.53	115.06		
	04	1		0.69	17.45	0.88	22.23			1.53	38.86	1.50	38.10
		2								2.53	64.26		
		3								3.53	89.66		
		4								4.53	115.06		
	05	1		0.81	20.62	1.00	25.40			1.53	38.86	1.65	41.91
		2								2.53	64.26		
		3								3.53	89.66		
		4								4.53	115.06		
	06	1		0.94	23.80	1.13	28.58			1.53	38.86	1.75	44.45
		2								2.53	64.26		
		3								3.53	89.66		
		4								4.53	115.06		
	07	1		1.06	26.97	1.25	31.75			1.53	38.86	1.90	48.26
		2								2.53	64.26		
		3								3.53	89.66		
		4								4.53	115.06		



Connector Group - L

90°, 45°

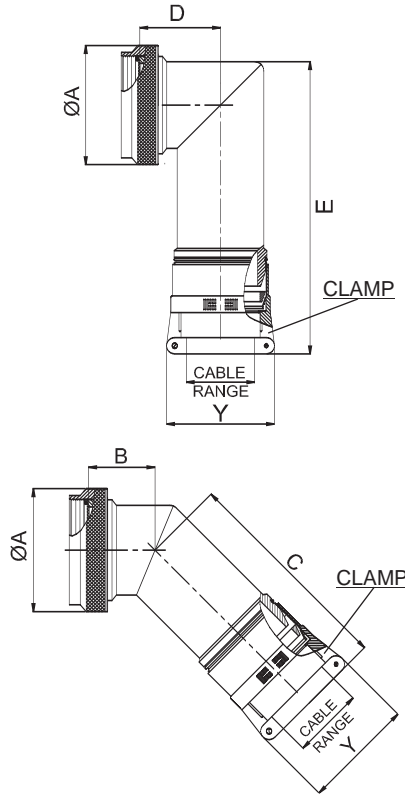

Amphenol Part Number

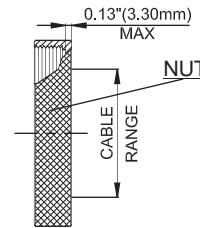
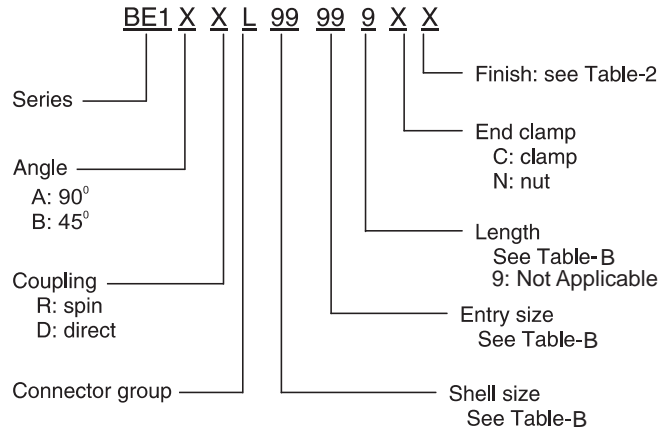

NOTE: * For more cable entry options, contact factory

TABLE - B

AMPHENOL PART NUMBER DESIGNATOR		CONNECTOR SHELL SIZE/CODE (REF.)	CABLE RANGE				A DIA. (MAX)		B (MAX)		C (MAX)		D (MAX)		E (MAX)		Y (MAX)	
SHELL SIZE	ENTRY SIZE		MIN		MAX		INCH	MM	INCH	MM	INCH	MM	INCH	MM	INCH	MM	INCH	MM
			INCH	MM	INCH	MM												
08	01	09 / A	0.06	1.57	0.13	3.18	0.75	19.05	0.46	11.68	3.15	80.01	0.69	17.53	3.46	87.88	0.80	20.32
	02		0.13	3.18	0.25	6.35											1.00	25.40
10	01	11 / B	0.06	1.57	0.13	3.18	0.85	21.59	0.52	13.21	3.21	81.53	0.78	19.81	3.58	90.93	0.80	20.32
	02		0.13	3.18	0.25	6.35											1.00	25.40
	03		0.25	6.35	0.38	9.53											1.10	27.94
12	01	13 / C	0.13	3.18	0.25	6.35	1.00	25.40	0.58	14.73	3.27	83.06	0.80	20.32	3.60	91.44	1.00	25.40
	02		0.25	6.35	0.38	9.53											1.10	27.94
	03		0.31	7.92	0.50	12.70											1.20	30.48
14	01	15 / D	0.13	3.18	0.25	6.35	1.15	29.21	0.65	16.51	3.36	85.34	0.88	22.35	3.67	93.22	1.00	25.40
	02		0.25	6.35	0.38	9.53											1.10	27.94
	03		0.31	7.92	0.50	12.70											1.20	30.48
	04		0.44	11.10	0.63	15.88											1.25	31.75
	01		0.13	3.18	0.25	6.35											1.00	25.40
16	02	17 / E	0.25	6.35	0.38	9.53	1.25	31.75	0.74	18.80	3.47	88.14	0.93	23.62	3.76	95.50	1.10	27.94
	03		0.31	7.92	0.50	12.70											1.20	30.48
	04		0.44	11.10	0.63	15.88											1.25	31.75
	05		0.56	14.27	0.75	19.05											1.40	35.56
	01		0.25	6.35	0.38	9.53											1.10	27.94
18	02	19 / F	0.31	7.92	0.50	12.70	1.40	35.56	0.93	23.62	3.66	92.96	1.01	25.65	3.93	99.82	1.20	30.48
	03		0.44	11.10	0.63	15.88											1.25	31.75
	04		0.56	14.27	0.75	19.05											1.40	35.56
	05		0.69	17.45	0.88	22.23											1.50	38.10
	01		0.25	6.35	0.38	9.53											1.10	27.94

Table Continued

Connector Group - L

90°, 45°

TABLE - B																		
AMPHENOL PART NUMBER DESIGNATOR		CONNECTOR SHELL SIZE/CODE (REF.)	CABLE RANGE				A DIA. (MAX)		B (MAX)		C (MAX)		D (MAX)		E (MAX)		Y (MAX)	
SHELL SIZE	ENTRY SIZE		MIN		MAX		INCH	MM	INCH	MM	INCH	MM	INCH	MM	INCH	MM	INCH	MM
			INCH	MM	INCH	MM												
20	01	21 / G	0.25	6.35	0.38	9.53	1.55	39.37	0.93	23.62	3.66	92.96	1.06	26.92	3.93	99.82	1.10	27.94
	02		0.31	7.92	0.50	12.70											1.20	30.48
	03		0.44	11.10	0.63	15.88											1.25	31.75
	04		0.56	14.27	0.75	19.05											1.40	35.56
	05		0.69	17.45	0.88	22.23											1.50	38.10
	06		0.81	20.62	1.00	25.40											1.65	41.91
22	01	23 / H	0.25	6.35	0.38	9.53	1.65	41.91	1.02	25.91	3.81	96.77	1.17	29.72	4.04	102.62	1.10	27.94
	02		0.31	7.92	0.50	12.70											1.20	30.48
	03		0.44	11.10	0.63	15.88											1.25	31.75
	04		0.56	14.27	0.75	19.05											1.40	35.56
	05		0.69	17.45	0.88	22.23											1.50	38.10
	06		0.81	20.62	1.00	25.40											1.65	41.91
	07		0.94	23.80	1.13	28.58											1.75	44.45
24	01	25 / J	0.31	7.92	0.50	12.70	1.85	46.99	1.02	25.91	3.81	96.77	1.18	29.97	4.04	102.62	1.20	30.48
	02		0.44	11.10	0.63	15.88											1.25	31.75
	03		0.56	14.27	0.75	19.05											1.40	35.56
	04		0.69	17.45	0.88	22.23											1.50	38.10
	05		0.81	20.62	1.00	25.40											1.65	41.91
	06		0.94	23.80	1.13	28.58											1.75	44.45
	07		1.06	26.97	1.25	31.75											1.90	48.26



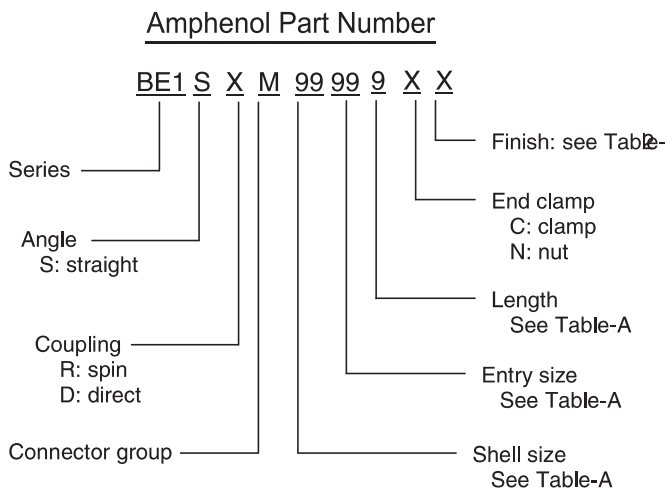
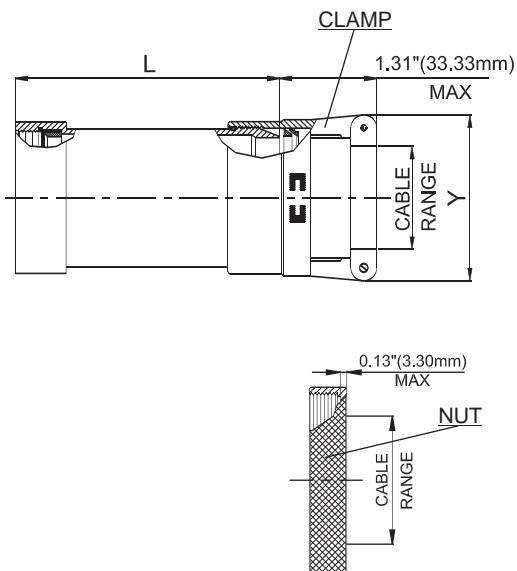

NOTE: * For more cable entry and length options, contact factory

TABLE - A											
AMPHENOL PART NUMBER DESIGNATOR			CONNECTOR SHELL SIZE	CABLE RANGE				L (MAX)		Y (MAX)	
SHELL SIZE	ENTRY SIZE	LENGTH		MIN		MAX		INCH	MM	INCH	MM
				INCH	MM	INCH	MM				
08	01	1	8	0.06	1.57	0.13	3.18	1.53	38.86	0.78	19.81
		2						2.53	64.26		
	02	1		0.13	3.18	0.25	6.35	1.53	38.86	0.97	24.64
		2						2.53	64.26		
10	01	1	10	0.06	1.57	0.13	3.18	1.53	38.86	0.78	19.81
		2						2.53	64.26		
	02	1		0.13	3.18	0.25	6.35	1.53	38.86	0.97	24.64
		2						2.53	64.26		
	03	1		0.25	6.35	0.38	9.53	1.53	38.86	1.06	26.92
		2						2.53	64.26		
12	01	1	12	0.13	3.18	0.25	6.35	1.53	38.86	0.97	24.64
		2						2.53	64.26		
	02	1		0.25	6.35	0.38	9.53	1.53	38.86	1.06	26.92
		2						2.53	64.26		
	03	1		0.31	7.92	0.50	12.70	1.53	38.86	1.16	29.46
		2						2.53	64.26		
14	01	1	14	0.13	3.18	0.25	6.35	1.53	38.86	0.97	24.64
		2						2.53	64.26		
		3						3.53	89.66		
	02	1		0.25	6.35	0.38	9.53	1.53	38.86	1.06	26.92
		2						2.53	64.26		
		3						3.53	89.66		
	03	1		0.31	7.92	0.50	12.70	1.53	38.86	1.16	29.46
		2						2.53	64.26		
		3						3.53	89.66		
	04	1		0.44	11.10	0.63	15.88	1.53	38.86	1.25	31.75
		2						2.53	64.26		
		3						3.53	89.66		

Table Continued

Connector Group - M

Straight

TABLE - A											
AMPHENOL PART NUMBER DESIGNATOR			CONNECTOR SHELL SIZE	CABLE RANGE				L (MAX)		Y (MAX)	
SHELL SIZE	ENTRY SIZE	LENGTH		MIN		MAX		INCH	MM	INCH	MM
				INCH	MM	INCH	MM				
16	01	1	16	0.13	3.18	0.25	6.35	1.53	38.86	0.97	24.64
		2						2.53	64.26		
		3						3.53	89.66		
	02	1		0.25	6.35	0.38	9.53	1.53	38.86	1.06	26.92
		2						2.53	64.26		
		3						3.53	89.66		
	03	1		0.31	7.92	0.50	12.70	1.53	38.86	1.16	29.46
		2						2.53	64.26		
		3						3.53	89.66		
	04	1		0.44	11.10	0.63	15.88	1.53	38.86	1.25	31.75
		2						2.53	64.26		
		3						3.53	89.66		
05	1	0.56	14.27	0.75	19.05	1.53	38.86	1.38	35.05		
	2					2.53	64.26				
	3					3.53	89.66				
18	01	1	18	0.25	6.35	0.38	9.53	1.53	38.86	1.06	26.92
		2						2.53	64.26		
		3						3.53	89.66		
	02	1		0.31	7.92	0.50	12.70	1.53	38.86	1.16	29.46
		2						2.53	64.26		
		3						3.53	89.66		
	03	1		0.44	11.10	0.63	15.88	1.53	38.86	1.25	31.75
		2						2.53	64.26		
		3						3.53	89.66		
	04	1		0.56	14.27	0.75	19.05	1.53	38.86	1.38	35.05
		2						2.53	64.26		
		3						3.53	89.66		
05	1	0.69	17.45	0.88	22.23	1.53	38.86	1.50	38.10		
	2					2.53	64.26				
	3					3.53	89.66				
20	01	1	20	0.25	6.35	0.38	9.53	1.53	38.86	1.06	26.92
		2						2.53	64.26		
		3						3.53	89.66		
		4						4.53	115.06		
	02	1		0.31	7.92	0.50	12.70	1.53	38.86	1.16	29.46
		2						2.53	64.26		
		3						3.53	89.66		
		4						4.53	115.06		
	03	1		0.44	11.10	0.63	15.88	1.53	38.86	1.25	31.75
		2						2.53	64.26		
		3						3.53	89.66		
		4						4.53	115.06		
	04	1		0.56	14.27	0.75	19.05	1.53	38.86	1.38	35.05
		2						2.53	64.26		
		3						3.53	89.66		
		4						4.53	115.06		
	05	1		0.69	17.45	0.88	22.23	1.53	38.86	1.50	38.10
		2						2.53	64.26		
		3						3.53	89.66		
		4						4.53	115.06		
	06	1		0.81	20.62	1.00	25.40	1.53	38.86	1.63	41.40
		2						2.53	64.26		
		3						3.53	89.66		
		4						4.53	115.06		

Table Continued



TABLE - A											
AMPHENOL PART NUMBER DESIGNATOR			CONNECTOR SHELL SIZE	CABLE RANGE				L (MAX)		Y (MAX)	
SHELL SIZE	ENTRY SIZE	LENGTH		MIN		MAX		INCH	MM	INCH	MM
				INCH	MM	INCH	MM				
22	01	1	22	0.25	6.35	0.38	9.53	1.53	38.86	1.06	26.92
		2						2.53	64.26		
		3						3.53	89.66		
		4						4.53	115.06		
	02	1		0.31	7.92	0.50	12.70	1.53	38.86	1.16	29.46
		2						2.53	64.26		
		3						3.53	89.66		
		4						4.53	115.06		
	03	1		0.44	11.10	0.63	15.88	1.53	38.86	1.25	31.75
		2						2.53	64.26		
		3						3.53	89.66		
		4						4.53	115.06		
	04	1		0.56	14.27	0.75	19.05	1.53	38.86	1.38	35.05
		2						2.53	64.26		
		3						3.53	89.66		
		4						4.53	115.06		
	05	1		0.69	17.45	0.88	22.23	1.53	38.86	1.50	38.10
		2						2.53	64.26		
		3						3.53	89.66		
		4						4.53	115.06		
	06	1		0.81	20.62	1.00	25.40	1.53	38.86	1.63	41.40
		2						2.53	64.26		
		3						3.53	89.66		
		4						4.53	115.06		
	07	1		0.94	23.80	1.13	28.58	1.53	38.86	1.75	44.45
		2						2.53	64.26		
		3						3.53	89.66		
		4						4.53	115.06		
24	01	1	24	0.31	7.92	0.50	12.70	1.53	38.86	1.16	29.46
		2						2.53	64.26		
		3						3.53	89.66		
		4						4.53	115.06		
	02	1		0.44	11.10	0.63	15.88	1.53	38.86	1.25	31.75
		2						2.53	64.26		
		3						3.53	89.66		
		4						4.53	115.06		
	03	1		0.56	14.27	0.75	19.05	1.53	38.86	1.38	35.05
		2						2.53	64.26		
		3						3.53	89.66		
		4						4.53	115.06		
	04	1		0.69	17.45	0.88	22.23	1.53	38.86	1.50	38.10
		2						2.53	64.26		
		3						3.53	89.66		
		4						4.53	115.06		
	05	1		0.81	20.62	1.00	25.40	1.53	38.86	1.63	41.40
		2						2.53	64.26		
		3						3.53	89.66		
		4						4.53	115.06		
	06	1		0.94	23.80	1.13	28.58	1.53	38.86	1.75	44.45
		2						2.53	64.26		
		3						3.53	89.66		
		4						4.53	115.06		
	07	1		1.06	26.97	1.25	31.75	1.53	38.86	1.88	47.75
		2						2.53	64.26		
		3						3.53	89.66		
		4						4.53	115.06		

Connector Group - M

90°, 45°

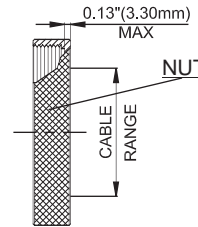
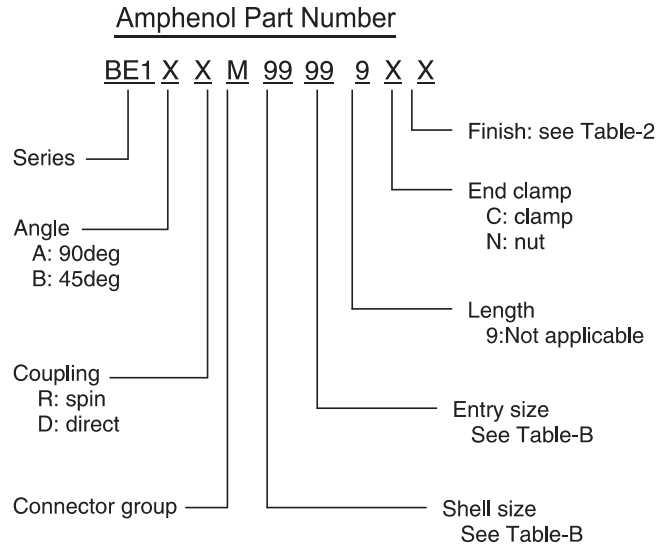
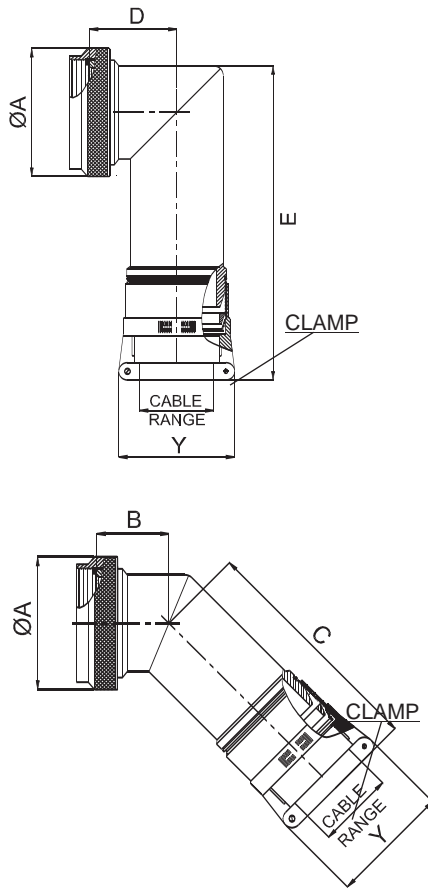

NOTE: * For more cable entry options, contact factory

TABLE - B																		
AMPHENOL PART NUMBER DESIGNATOR		CONNECTOR SHELL SIZE	CABLE RANGE				A DIA. (MAX)		B (MAX)		C (MAX)		D (MAX)		E (MAX)		Y (MAX)	
SHELL SIZE	ENTRY SIZE		MIN	MAX	MIN	MAX	INCH	MM	INCH	MM	INCH	MM	INCH	MM	INCH	MM	INCH	MM
08	01	8	0.06	1.57	0.13	3.18	0.75	19.05	0.46	11.68	3.15	80.01	0.69	17.53	3.46	87.88	0.78	19.81
	02		0.13	3.18	0.25	6.35											0.97	24.64
10	01	10	0.06	1.57	0.13	3.18	0.85	21.59	0.52	13.21	3.21	81.53	0.78	19.81	3.58	90.93	0.78	19.81
	02		0.13	3.18	0.25	6.35											0.97	24.64
	03		0.25	6.35	0.38	9.53											1.06	26.92
12	01	12	0.13	3.18	0.25	6.35	1.00	25.40	0.58	14.73	3.27	83.06	0.80	20.32	3.60	91.44	0.97	24.64
	02		0.25	6.35	0.38	9.53											1.06	26.92
	03		0.31	7.92	0.50	12.70											1.16	29.46
14	01	14	0.13	3.18	0.25	6.35	1.15	29.21	0.65	16.51	3.36	85.34	0.88	22.35	3.67	93.22	0.97	24.64
	02		0.25	6.35	0.38	9.53											1.06	26.92
	03		0.31	7.92	0.50	12.70											1.16	29.46
	04		0.44	11.10	0.63	15.88											1.25	31.75

Table Continued

TABLE - B

AMPHENOL PART NUMBER DESIGNATOR		CONNECTOR SHELL SIZE	CABLE RANGE				A DIA. (MAX)		B (MAX)		C (MAX)		D (MAX)		E (MAX)		Y (MAX)	
SHELL SIZE	ENTRY SIZE		MIN		MAX		INCH	MM	INCH	MM	INCH	MM	INCH	MM	INCH	MM	INCH	MM
			INCH	MM	INCH	MM												
16	01	16	0.13	3.18	0.25	6.35	1.25	31.75	0.74	18.80	3.47	88.14	0.93	23.62	3.76	95.50	0.97	24.64
	02		0.25	6.35	0.38	9.53											1.06	26.92
	03		0.31	7.92	0.50	12.70											1.16	29.46
	04		0.44	11.10	0.63	15.88											1.25	31.75
	05		0.56	14.27	0.75	19.05											1.38	35.05
18	01	18	0.25	6.35	0.38	9.53	1.40	35.56	0.93	23.62	3.66	92.96	1.01	25.65	3.93	99.82	1.06	26.92
	02		0.31	7.92	0.50	12.70											1.16	29.46
	03		0.44	11.10	0.63	15.88											1.25	31.75
	04		0.56	14.27	0.75	19.05											1.38	35.05
	05		0.69	17.45	0.88	22.23											1.50	38.10
20	01	20	0.25	6.35	0.38	9.53	1.55	39.37	0.93	23.62	3.66	92.96	1.06	26.92	3.93	99.82	1.06	26.92
	02		0.31	7.92	0.50	12.70											1.16	29.46
	03		0.44	11.10	0.63	15.88											1.25	31.75
	04		0.56	14.27	0.75	19.05											1.38	35.05
	05		0.69	17.45	0.88	22.23											1.50	38.10
	06		0.81	20.62	1.00	25.40											1.63	41.40
22	01	22	0.25	6.35	0.38	9.53	1.65	41.91	1.02	25.91	3.81	96.77	1.17	29.72	4.04	102.62	1.06	26.92
	02		0.31	7.92	0.50	12.70											1.16	29.46
	03		0.44	11.10	0.63	15.88											1.25	31.75
	04		0.56	14.27	0.75	19.05											1.38	35.05
	05		0.69	17.45	0.88	22.23											1.50	38.10
	06		0.81	20.62	1.00	25.40											1.63	41.40
	07		0.94	23.80	1.13	28.58											1.75	44.45
24	01	24	0.31	7.92	0.50	12.70	1.85	46.99	1.02	25.91	3.81	96.77	1.18	29.97	4.04	102.62	1.16	29.46
	02		0.44	11.10	0.63	15.88											1.25	31.75
	03		0.56	14.27	0.75	19.05											1.38	35.05
	04		0.69	17.45	0.88	22.23											1.50	38.10
	05		0.81	20.62	1.00	25.40											1.63	41.40
	06		0.94	23.80	1.13	28.58											1.75	44.45
	07		1.06	26.97	1.25	31.75											1.88	47.75

Connector Group - N

Straight

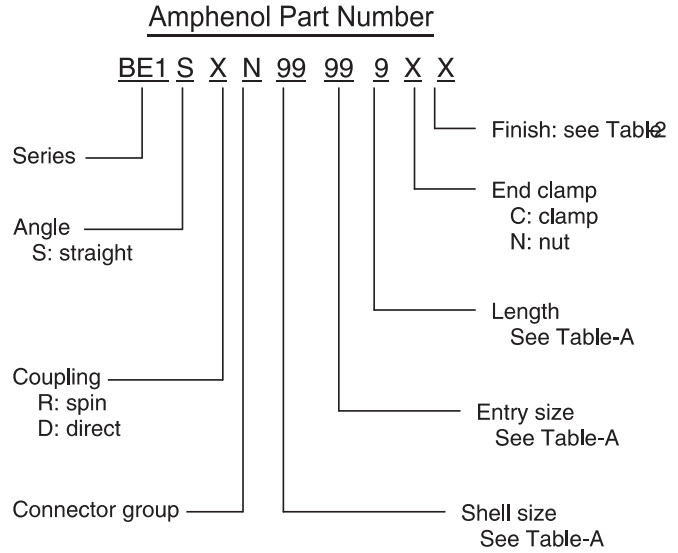
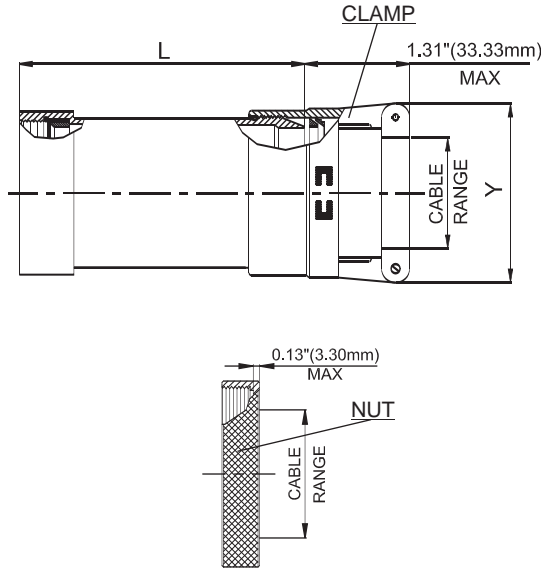

NOTE: * For more cable entry and length options, contact factory

TABLE - A											
AMPHENOL PART NUMBER DESIGNATOR			CONNECTOR SHELL SIZE	CABLE RANGE				L (MAX)		Y (MAX)	
SHELL SIZE	ENTRY SIZE	LENGTH		MIN		MAX		INCH	MM	INCH	MM
				INCH	MM	INCH	MM				
08	01	1	8	0.06	1.57	0.13	3.18	1.53	38.86	0.78	19.81
		2						2.53	64.26		
	02	1		0.13	3.18	0.25	6.35	1.53	38.86	0.97	24.64
		2						2.53	64.26		
10	01	1	10	0.06	1.57	0.13	3.18	1.53	38.86	0.78	19.81
		2						2.53	64.26		
	02	1		0.13	3.18	0.25	6.35	1.53	38.86	0.97	24.64
		2						2.53	64.26		
	03	1		0.25	6.35	0.38	9.53	1.53	38.86	1.06	26.92
		2						2.53	64.26		
12	01	1	12	0.13	3.18	0.25	6.35	1.53	38.86	0.97	24.64
		2						2.53	64.26		
	02	1		0.25	6.35	0.38	9.53	1.53	38.86	1.06	26.92
		2						2.53	64.26		
	03	1		0.31	7.92	0.50	12.70	1.53	38.86	1.16	29.46
		2						2.53	64.26		
14	01	1	14	0.13	3.18	0.25	6.35	1.53	38.86	0.97	24.64
		2						2.53	64.26		
		3						3.53	89.66		
	02	1		0.25	6.35	0.38	9.53	1.53	38.86	1.06	26.92
		2						2.53	64.26		
		3						3.53	89.66		
	03	1		0.31	7.92	0.50	12.70	1.53	38.86	1.16	29.46
		2						2.53	64.26		
		3						3.53	89.66		
	04	1		0.44	11.10	0.63	15.88	1.53	38.86	1.25	31.75
		2						2.53	64.26		
		3						3.53	89.66		

Table Continued

TABLE - A											
AMPHENOL PART NUMBER DESIGNATOR			CONNECTOR SHELL SIZE	CABLE RANGE				L (MAX)		Y (MAX)	
SHELL SIZE	ENTRY SIZE	LENGTH		MIN		MAX		INCH	MM	INCH	MM
				INCH	MM	INCH	MM				
16	01	1	16	0.13	3.18	0.25	6.35	1.53	38.86	0.97	24.64
		2						2.53	64.26		
		3						3.53	89.66		
	02	1		0.25	6.35	0.38	9.53	1.53	38.86	1.06	26.92
		2						2.53	64.26		
		3						3.53	89.66		
	03	1		0.31	7.92	0.50	12.70	1.53	38.86	1.16	29.46
		2						2.53	64.26		
		3						3.53	89.66		
	04	1		0.44	11.10	0.63	15.88	1.53	38.86	1.25	31.75
		2						2.53	64.26		
		3						3.53	89.66		
	05	1		0.56	14.27	0.75	19.05	1.53	38.86	1.38	35.05
		2						2.53	64.26		
		3						3.53	89.66		
18	01	1	18	0.25	6.35	0.38	9.53	1.53	38.86	1.06	26.92
		2						2.53	64.26		
		3						3.53	89.66		
	02	1		0.31	7.92	0.50	12.70	1.53	38.86	1.16	29.46
		2						2.53	64.26		
		3						3.53	89.66		
	03	1		0.44	11.10	0.63	15.88	1.53	38.86	1.25	31.75
		2						2.53	64.26		
		3						3.53	89.66		
	04	1		0.56	14.27	0.75	19.05	1.53	38.86	1.38	35.05
		2						2.53	64.26		
		3						3.53	89.66		
	05	1		0.69	17.45	0.88	22.23	1.53	38.86	1.50	38.10
		2						2.53	64.26		
		3						3.53	89.66		
20	01	1	20	0.25	6.35	0.38	9.53	1.53	38.86	1.06	26.92
		2						2.53	64.26		
		3						3.53	89.66		
		4						4.53	115.06		
	02	1		0.31	7.92	0.50	12.70	1.53	38.86	1.16	29.46
		2						2.53	64.26		
		3						3.53	89.66		
		4						4.53	115.06		
	03	1		0.44	11.10	0.63	15.88	1.53	38.86	1.25	31.75
		2						2.53	64.26		
		3						3.53	89.66		
		4						4.53	115.06		
	04	1		0.56	14.27	0.75	19.05	1.53	38.86	1.38	35.05
		2						2.53	64.26		
		3						3.53	89.66		
		4						4.53	115.06		
	05	1		0.69	17.45	0.88	22.23	1.53	38.86	1.50	38.10
		2						2.53	64.26		
		3						3.53	89.66		
		4						4.53	115.06		
	06	1		0.81	20.62	1.00	25.40	1.53	38.86	1.63	41.40
		2						2.53	64.26		
		3						3.53	89.66		
		4						4.53	115.06		

Table Continued



Connector Group - N

Straight

TABLE - A											
AMPHENOL PART NUMBER DESIGNATOR			CONNECTOR SHELL SIZE	CABLE RANGE				L (MAX)		Y (MAX)	
SHELL SIZE	ENTRY SIZE	LENGTH		MIN		MAX		INCH	MM	INCH	MM
				INCH	MM	INCH	MM				
20	01	1	20	0.25	6.35	0.38	9.53	1.53	38.86	1.06	26.92
		2						2.53	64.26		
		3						3.53	89.66		
		4						4.53	115.06		
	02	1		0.31	7.92	0.50	12.70	1.53	38.86	1.16	29.46
		2						2.53	64.26		
		3						3.53	89.66		
		4						4.53	115.06		
	03	1		0.44	11.10	0.63	15.88	1.53	38.86	1.25	31.75
		2						2.53	64.26		
		3						3.53	89.66		
		4						4.53	115.06		
	04	1		0.56	14.27	0.75	19.05	1.53	38.86	1.38	35.05
		2						2.53	64.26		
		3						3.53	89.66		
		4						4.53	115.06		
	05	1		0.69	17.45	0.88	22.23	1.53	38.86	1.50	38.10
		2						2.53	64.26		
		3						3.53	89.66		
		4						4.53	115.06		
	06	1		0.81	20.62	1.00	25.40	1.53	38.86	1.63	41.40
		2						2.53	64.26		
		3						3.53	89.66		
		4						4.53	115.06		
22	01	1	22	0.25	6.35	0.38	9.53	1.53	38.86	1.06	26.92
		2						2.53	64.26		
		3						3.53	89.66		
		4						4.53	115.06		
	02	1		0.31	7.92	0.50	12.70	1.53	38.86	1.16	29.46
		2						2.53	64.26		
		3						3.53	89.66		
		4						4.53	115.06		
	03	1		0.44	11.10	0.63	15.88	1.53	38.86	1.25	31.75
		2						2.53	64.26		
		3						3.53	89.66		
		4						4.53	115.06		
	04	1		0.56	14.27	0.75	19.05	1.53	38.86	1.38	35.05
		2						2.53	64.26		
		3						3.53	89.66		
		4						4.53	115.06		
	05	1		0.69	17.45	0.88	22.23	1.53	38.86	1.50	38.10
		2						2.53	64.26		
		3						3.53	89.66		
		4						4.53	115.06		
	06	1		0.81	20.62	1.00	25.40	1.53	38.86	1.63	41.40
		2						2.53	64.26		
		3						3.53	89.66		
		4						4.53	115.06		
	07	1		0.94	23.80	1.13	28.58	1.53	38.86	1.75	44.45
		2						2.53	64.26		
		3						3.53	89.66		
		4						4.53	115.06		

Table Continued



Connector Group - N

Straight

TABLE - A											
AMPHENOL PART NUMBER DESIGNATOR			CONNECTOR SHELL SIZE	CABLE RANGE				L (MAX)		Y (MAX)	
SHELL SIZE	ENTRY SIZE	LENGTH		MIN		MAX		INCH	MM	INCH	MM
				INCH	MM	INCH	MM				
24	01	1	24	0.31	7.92	0.50	12.70	1.53	38.86	1.16	29.46
		2						2.53	64.26		
		3						3.53	89.66		
		4						4.53	115.06		
	02	1		0.44	11.10	0.63	15.88	1.53	38.86	1.25	31.75
		2						2.53	64.26		
		3						3.53	89.66		
		4						4.53	115.06		
	03	1		0.56	14.27	0.75	19.05	1.53	38.86	1.38	35.05
		2						2.53	64.26		
		3						3.53	89.66		
		4						4.53	115.06		
	04	1		0.69	17.45	0.88	22.23	1.53	38.86	1.50	38.10
		2						2.53	64.26		
		3						3.53	89.66		
		4						4.53	115.06		
	05	1		0.81	20.62	1.00	25.40	1.53	38.86	1.63	41.40
		2						2.53	64.26		
		3						3.53	89.66		
		4						4.53	115.06		
	06	1		0.94	23.80	1.13	28.58	1.53	38.86	1.75	44.45
		2						2.53	64.26		
		3						3.53	89.66		
		4						4.53	115.06		
	07	1		1.06	26.97	1.25	31.75	1.53	38.86	1.88	47.75
		2						2.53	64.26		
		3						3.53	89.66		
		4						4.53	115.06		

Connector Group - N

90°, 45°

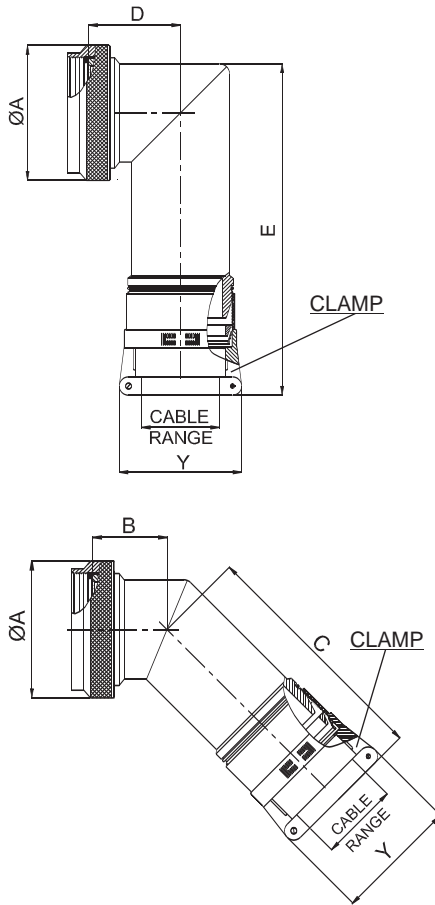

Amphenol Part Number

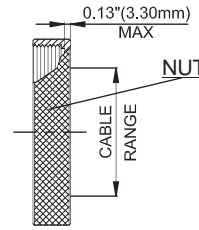
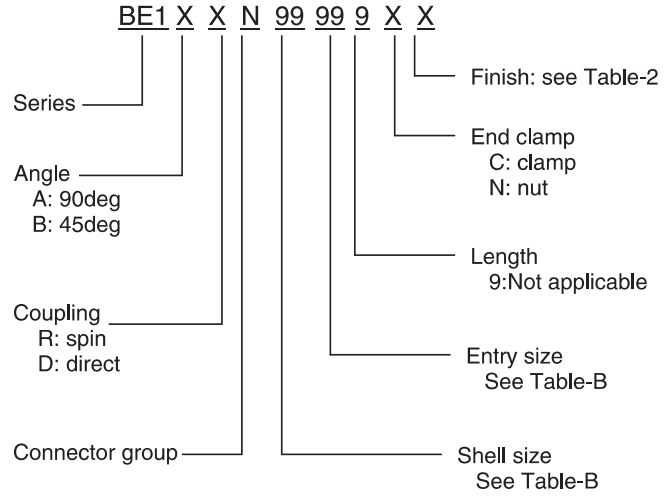

NOTE: * For more cable entry options, contact factory

TABLE - B

AMPHENOL PART NUMBER DESIGNATOR		CONNECTOR SHELL SIZE	CABLE RANGE				A DIA. (MAX)		B (MAX)		C (MAX)		D (MAX)		E (MAX)		Y (MAX)	
SHELL SIZE	ENTRY SIZE		MIN		MAX		INCH	MM	INCH	MM	INCH	MM	INCH	MM	INCH	MM	INCH	MM
			INCH	MM	INCH	MM												
08	01	8	0.06	1.57	0.13	3.18	0.75	19.05	0.46	11.68	3.15	80.01	0.69	17.53	3.46	87.88	0.78	19.81
	02		0.13	3.18	0.25	6.35											0.97	24.64
10	01	10	0.06	1.57	0.13	3.18	0.85	21.59	0.52	13.21	3.21	81.53	0.78	19.81	3.58	90.93	0.78	19.81
	02		0.13	3.18	0.25	6.35											0.97	24.64
	03		0.25	6.35	0.38	9.53											1.06	26.92
12	01	12	0.13	3.18	0.25	6.35	1.00	25.40	0.58	14.73	3.27	83.06	0.80	20.32	3.60	91.44	0.97	24.64
	02		0.25	6.35	0.38	9.53											1.06	26.92
	03		0.31	7.92	0.50	12.70											1.16	29.46
14	01	14	0.13	3.18	0.25	6.35	1.15	29.21	0.65	16.51	3.36	85.34	0.88	22.35	3.67	93.22	0.97	24.64
	02		0.25	6.35	0.38	9.53											1.06	26.92
	03		0.31	7.92	0.50	12.70											1.16	29.46
	04		0.44	11.10	0.63	15.88											1.25	31.75

Table Continued

TABLE - B

AMPHENOL PART NUMBER DESIGNATOR		CONNECTOR SHELL SIZE	CABLE RANGE				A DIA. (MAX)		B (MAX)		C (MAX)		D (MAX)		E (MAX)		Y (MAX)	
SHELL SIZE	ENTRY SIZE		MIN		MAX		INCH	MM	INCH	MM	INCH	MM	INCH	MM	INCH	MM	INCH	MM
			INCH	MM	INCH	MM												
16	01	16	0.13	3.18	0.25	6.35	1.25	31.75	0.74	18.80	3.47	88.14	0.93	23.62	3.76	95.50	0.97	24.64
	02		0.25	6.35	0.38	9.53											1.06	26.92
	03		0.31	7.92	0.50	12.70											1.16	29.46
	04		0.44	11.10	0.63	15.88											1.25	31.75
	05		0.56	14.27	0.75	19.05											1.38	35.05
18	01	18	0.25	6.35	0.38	9.53	1.40	35.56	0.93	23.62	3.66	92.96	1.01	25.65	3.93	99.82	1.06	26.92
	02		0.31	7.92	0.50	12.70											1.16	29.46
	03		0.44	11.10	0.63	15.88											1.25	31.75
	04		0.56	14.27	0.75	19.05											1.38	35.05
	05		0.69	17.45	0.88	22.23											1.50	38.10
20	01	20	0.25	6.35	0.38	9.53	1.55	39.37	0.93	23.62	3.66	92.96	1.06	26.92	3.93	99.82	1.06	26.92
	02		0.31	7.92	0.50	12.70											1.16	29.46
	03		0.44	11.10	0.63	15.88											1.25	31.75
	04		0.56	14.27	0.75	19.05											1.38	35.05
	05		0.69	17.45	0.88	22.23											1.50	38.10
	06		0.81	20.62	1.00	25.40											1.63	41.40
22	01	22	0.25	6.35	0.38	9.53	1.65	41.91	1.02	25.91	3.81	96.77	1.17	29.72	4.04	102.62	1.06	26.92
	02		0.31	7.92	0.50	12.70											1.16	29.46
	03		0.44	11.10	0.63	15.88											1.25	31.75
	04		0.56	14.27	0.75	19.05											1.38	35.05
	05		0.69	17.45	0.88	22.23											1.50	38.10
	06		0.81	20.62	1.00	25.40											1.63	41.40
	07		0.94	23.80	1.13	28.58											1.75	44.45
24	01	24	0.31	7.92	0.50	12.70	1.85	46.99	1.02	25.91	3.81	96.77	1.18	29.97	4.04	102.62	1.16	29.46
	02		0.44	11.10	0.63	15.88											1.25	31.75
	03		0.56	14.27	0.75	19.05											1.38	35.05
	04		0.69	17.45	0.88	22.23											1.50	38.10
	05		0.81	20.62	1.00	25.40											1.63	41.40
	06		0.94	23.80	1.13	28.58											1.75	44.45
	07		1.06	26.97	1.25	31.75											1.88	47.75