

DO NOT SCALE DRAWING

REVISION

A INITIAL DRAWING 07.01.2016

Part Number	ØA	B Nom	C Nom	D Length	Recess Size
M2 6 PRSTMC Z100	M2-0.4	4.0	1.6	6	Pozi #1
M2 12 PRSTMC Z100				12	
M2.5 6 PRSTMC Z100	M2.5-0.45	5.0	2.0	6	Pozi #1
M2.5 10 PRSTMC Z100				10	
M2.5 12 PRSTMC Z100				12	
M2.5 20 PRSTMC Z100				20	
M3 6 PRSTMC Z100	M3-0.5	6.0	2.4	6	Pozi #1
M3 8 PRSTMC Z100				8	
M3 10 PRSTMC Z100				10	
M3 12 PRSTMC Z100				12	
M3 16 PRSTMC Z100				16	
M3 20 PRSTMC Z100				20	
M3 25 PRSTMC Z100				25	
M3 30 PRSTMC Z100	30				
M3.5 6 PRSTMC Z100	M3.5-0.6	7.0	2.7	6	Pozi #2
M3.5 10 PRSTMC Z100				10	
M3.5 12 PRSTMC Z100				12	
M3.5 16 PRSTMC Z100				16	
M3.5 20 PRSTMC Z100	20				
M4 6 PRSTMC Z100	M4-0.7	8.0	3.1	6	Pozi #2
M4 8 PRSTMC Z100				8	
M4 10 PRSTMC Z100				10	
M4 12 PRSTMC Z100				12	
M4 16 PRSTMC Z100				16	
M4 20 PRSTMC Z100				20	
M4 30 PRSTMC Z100	30				
M4 40 PRSTMC Z100	40				
M5 6 PRSTMC Z100	M5-0.8	10.0	3.8	6	Pozi #2
M5 10 PRSTMC Z100				10	
M5 12 PRSTMC Z100				12	
M5 16 PRSTMC Z100				16	
M5 20 PRSTMC Z100				20	
M5 25 PRSTMC Z100				25	
M5 40 PRSTMC Z100	40				
M6 10 PRSTMC Z100	M6-1.0	12.0	4.6	10	Pozi #3
M6 12 PRSTMC Z100				12	
M6 16 PRSTMC Z100				16	
M6 20 PRSTMC Z100				20	
M6 25 PRSTMC Z100				25	
M6 40 PRSTMC Z100	40				

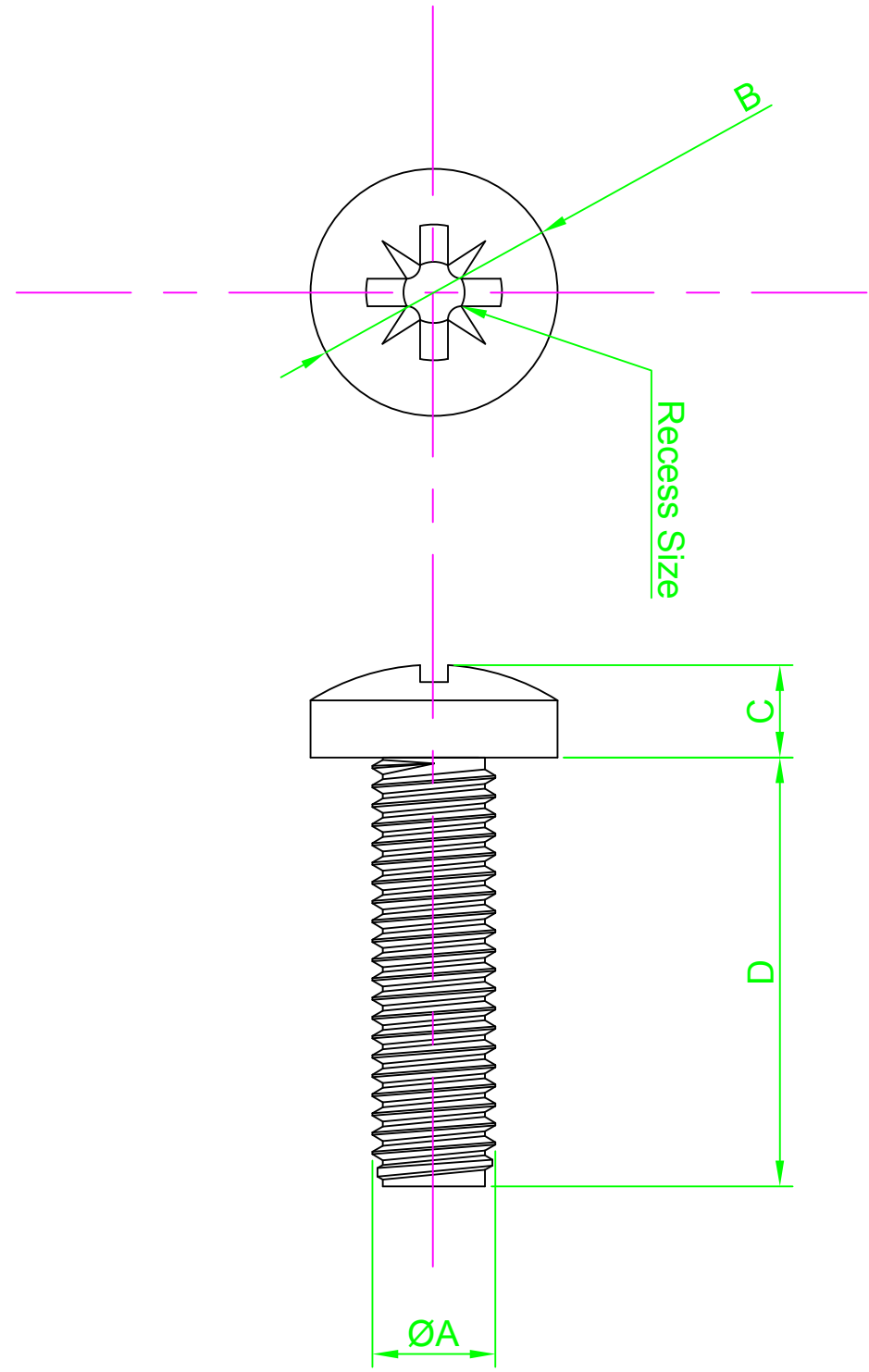

NOTES:



UNLESS OTHERWISE SPECIFIED:
DIMENSIONS ARE IN MM (MILLIMETERS).
SURFACE FINISH:
TOLERANCES: DIN 7985

MATERIAL:
Steel

TITLE:
Pozi Pan Head Machine Screw DIN 7985

	NAME	DATE
DRAWN	Darryl Wilson	07.01.16
CHK'D		
APPVD		

HEAT TREATMENT:

DESIGN RIGHT. TR FASTENINGS LTD, 2003
UNDER NO CIRCUMSTANCES MUST THIS
DRAWING BE COPIED OR DISCLOSED
WITHOUT FIRST OBTAINING WRITTEN
AUTHORITY.

CUSTOMER PART NUMBER:
N/A

FINISH:
TC1 - Commercial Zinc/Clear Trivalent

DRAWING NUMBER:
TR32PRSTMC-Z100

A4

