

DO NOT SCALE DRAWING

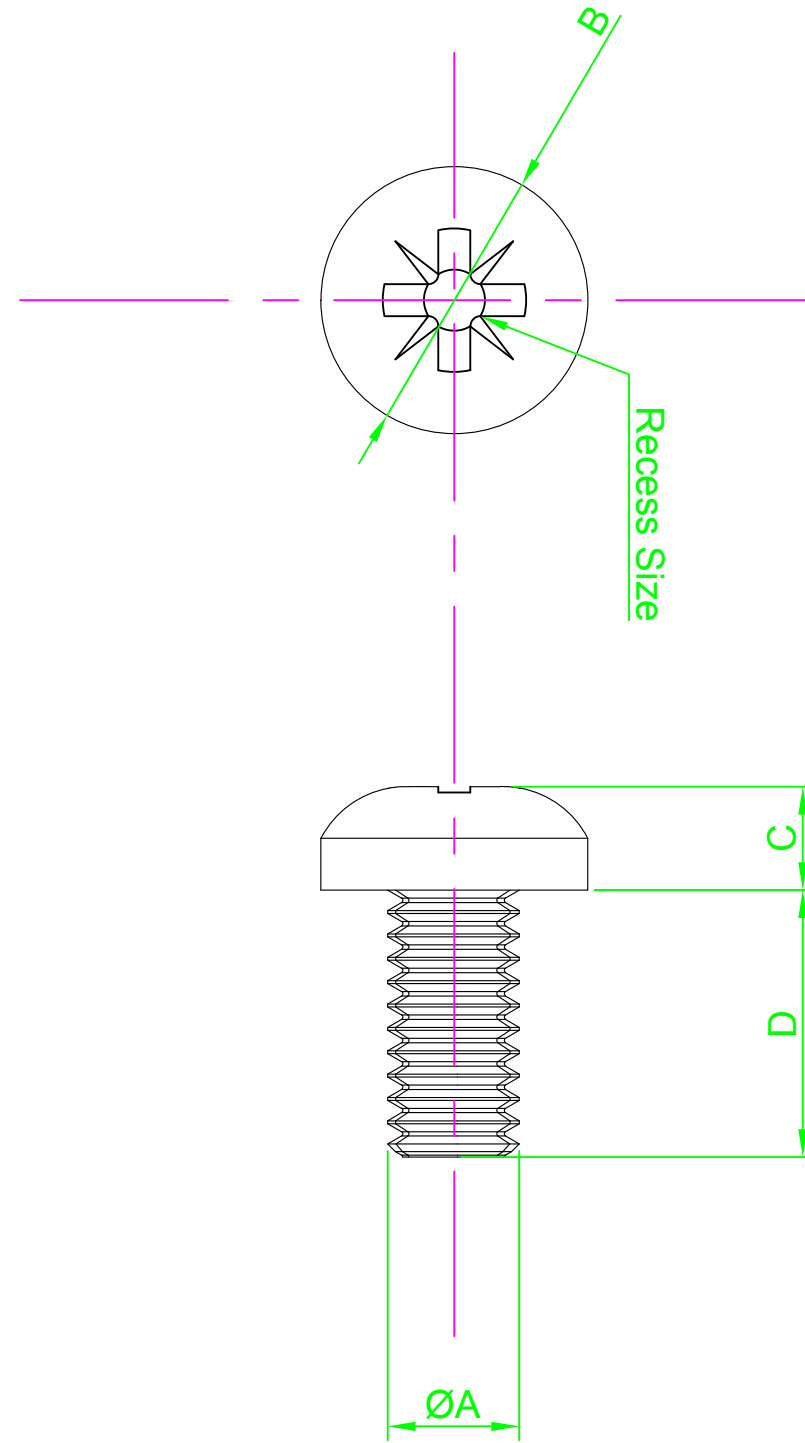
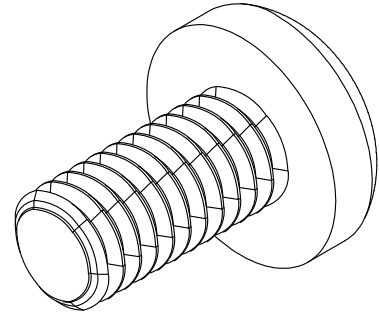

REVISION

A INITIAL DRAWING 21.9.15

Part Number	ØA	B Nom	C Nom	Recess Size	D Length
M2.5 6 PRSTTT Z100	M2.5-0.45	5.0	2.0	Pozi #1	6
M2.5 8 PRSTTT Z100					8
M3 5 PRSTTT Z100	M3-0.5	6.0	2.4	Pozi #1	5
M3 6 PRSTTT Z100					6
M3 8 PRSTTT Z100					8
M3 10 PRSTTT Z100					10
M3 12 PRSTTT Z100	M3.5-0.6	7.0	2.7	Pozi #2	12
M3.5 6 PRSTTT Z100					6
M3.5 8 PRSTTT Z100	M4-0.7	8.0	3.1	Pozi #2	8
M4 6 PRSTTT Z100					6
M4 8 PRSTTT Z100					8
M4 10 PRSTTT Z100					10
M4 12 PRSTTT Z100	M5-0.8	10.0	3.8	Pozi #2	12
M4 16 PRSTTT Z100					16
M5 8 PRSTTT Z100	M6-1.0	12.0	4.6	Pozi #3	8
M5 12 PRSTTT Z100					12
M5 16 PRSTTT Z100					16
M6 12 PRSTTT Z100					12

NOTES:



UNLESS OTHERWISE SPECIFIED:
DIMENSIONS ARE IN MM (MILLIMETERS).
SURFACE FINISH:
TOLERANCES: DIN 7500

MATERIAL:
Steel

TITLE:
Pozi Pan Hd Thread Rolling Screw DIN7500

	NAME	DATE
DRAWN	Darryl Wilson	21.09.15
CHK'D		
APPVD		

HEAT TREATMENT:
Case Hardened

DESIGN RIGHT. TR FASTENINGS LTD, 2003
UNDER NO CIRCUMSTANCES MUST THIS
DRAWING BE COPIED OR DISCLOSED
WITHOUT FIRST OBTAINING WRITTEN
AUTHORITY.

CUSTOMER PART NUMBER:
N/A

FINISH:
TC1D - Commercial Zinc/Clear Trivalent
De-Embrittle

DRAWING NUMBER:
TR32PRSTTT

A4

