

Chip Inductor (Chip Coil) for High Frequency Horizontal Wire Wound

LQW2UA Series (1008 Size)

■ Dimensions

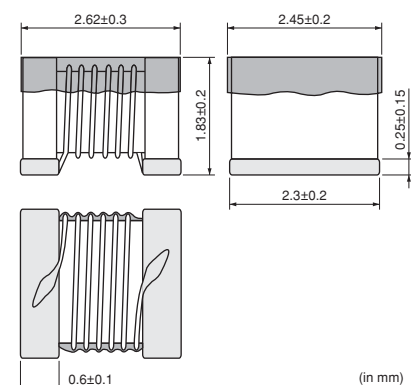

■ Packaging

Code	Packaging	Minimum Quantity
L	180mm Embossed Tape	2000

■ Rated Value (□: packaging code)

Part Number	Inductance	Test Frequency	Rated Current	Max. of DC Resistance	Q (min.)	Test Frequency	Self Resonance Frequency (min.)
LQW2UAS12NG00□	12nH ±2%	50MHz	1000mA	0.09ohm	50	500MHz	3300MHz
LQW2UAS12NJ00□	12nH ±5%	50MHz	1000mA	0.09ohm	50	500MHz	3300MHz
LQW2UAS18NG00□	18nH ±2%	50MHz	1000mA	0.11ohm	50	350MHz	2500MHz
LQW2UAS18NJ00□	18nH ±5%	50MHz	1000mA	0.11ohm	50	350MHz	2500MHz
LQW2UAS22NG00□	22nH ±2%	50MHz	1000mA	0.12ohm	55	350MHz	2400MHz
LQW2UAS22NJ00□	22nH ±5%	50MHz	1000mA	0.12ohm	55	350MHz	2400MHz
LQW2UAS27NG00□	27nH ±2%	50MHz	1000mA	0.13ohm	55	350MHz	1600MHz
LQW2UAS27NJ00□	27nH ±5%	50MHz	1000mA	0.13ohm	55	350MHz	1600MHz
LQW2UAS33NG00□	33nH ±2%	50MHz	1000mA	0.14ohm	60	350MHz	1600MHz
LQW2UAS33NJ00□	33nH ±5%	50MHz	1000mA	0.14ohm	60	350MHz	1600MHz
LQW2UAS39NG00□	39nH ±2%	50MHz	1000mA	0.15ohm	60	350MHz	1500MHz
LQW2UAS39NJ00□	39nH ±5%	50MHz	1000mA	0.15ohm	60	350MHz	1500MHz
LQW2UAS47NG00□	47nH ±2%	50MHz	1000mA	0.16ohm	65	350MHz	1500MHz
LQW2UAS47NJ00□	47nH ±5%	50MHz	1000mA	0.16ohm	65	350MHz	1500MHz
LQW2UAS56NG00□	56nH ±2%	50MHz	1000mA	0.18ohm	65	350MHz	1300MHz
LQW2UAS56NJ00□	56nH ±5%	50MHz	1000mA	0.18ohm	65	350MHz	1300MHz
LQW2UAS68NG00□	68nH ±2%	50MHz	1000mA	0.2ohm	65	350MHz	1300MHz
LQW2UAS68NJ00□	68nH ±5%	50MHz	1000mA	0.2ohm	65	350MHz	1300MHz
LQW2UAS82NG00□	82nH ±2%	50MHz	1000mA	0.22ohm	60	350MHz	1000MHz
LQW2UAS82NJ00□	82nH ±5%	50MHz	1000mA	0.22ohm	60	350MHz	1000MHz
LQW2UASR10G00□	100nH ±2%	25MHz	650mA	0.56ohm	60	350MHz	1000MHz
LQW2UASR10J00□	100nH ±5%	25MHz	650mA	0.56ohm	60	350MHz	1000MHz
LQW2UASR12G00□	120nH ±2%	25MHz	650mA	0.63ohm	60	350MHz	950MHz
LQW2UASR12J00□	120nH ±5%	25MHz	650mA	0.63ohm	60	350MHz	950MHz
LQW2UASR15G00□	150nH ±2%	25MHz	580mA	0.7ohm	45	100MHz	850MHz
LQW2UASR15J00□	150nH ±5%	25MHz	580mA	0.7ohm	45	100MHz	850MHz

Operating Temperature Range (Self-temperature rise is not included): -55 to +125°C

Only for reflow soldering.

Continued on the following page.

● This data sheet is applied for CHIP INDUCTORS (CHIP COILS) used for General Electronics equipment for your design.

⚠ Note:

- This datasheet is downloaded from the website of Murata Manufacturing co., ltd. Therefore, it's specifications are subject to change or our products in it may be discontinued without advance notice. Please check with our sales representatives or product engineers before ordering.
- This datasheet has only typical specifications because there is no space for detailed specifications. Therefore, please approve our product specifications or transact the approval sheet for product specifications before ordering.

 Continued from the preceding page.

Part Number	Inductance	Test Frequency	Rated Current	Max. of DC Resistance	Q (min.)	Test Frequency	Self Resonance Frequency (min.)
LQW2UASR18G00□	180nH ±2%	25MHz	620mA	0.77ohm	45	100MHz	750MHz
LQW2UASR18J00□	180nH ±5%	25MHz	620mA	0.77ohm	45	100MHz	750MHz
LQW2UASR22G00□	220nH ±2%	25MHz	500mA	0.84ohm	45	100MHz	700MHz
LQW2UASR22J00□	220nH ±5%	25MHz	500mA	0.84ohm	45	100MHz	700MHz
LQW2UASR27G00□	270nH ±2%	25MHz	500mA	0.91ohm	45	100MHz	600MHz
LQW2UASR27J00□	270nH ±5%	25MHz	500mA	0.91ohm	45	100MHz	600MHz
LQW2UASR33G00□	330nH ±2%	25MHz	450mA	1.05ohm	45	100MHz	570MHz
LQW2UASR33J00□	330nH ±5%	25MHz	450mA	1.05ohm	45	100MHz	570MHz
LQW2UASR39G00□	390nH ±2%	25MHz	470mA	1.12ohm	45	100MHz	500MHz
LQW2UASR39J00□	390nH ±5%	25MHz	470mA	1.12ohm	45	100MHz	500MHz
LQW2UASR47G00□	470nH ±2%	25MHz	470mA	1.19ohm	45	100MHz	450MHz
LQW2UASR47J00□	470nH ±5%	25MHz	470mA	1.19ohm	45	100MHz	450MHz
LQW2UASR56G00□	560nH ±2%	25MHz	400mA	1.33ohm	45	100MHz	415MHz
LQW2UASR56J00□	560nH ±5%	25MHz	400mA	1.33ohm	45	100MHz	415MHz
LQW2UASR62G00□	620nH ±2%	25MHz	300mA	1.4ohm	45	100MHz	375MHz
LQW2UASR62J00□	620nH ±5%	25MHz	300mA	1.4ohm	45	100MHz	375MHz
LQW2UASR68G00□	680nH ±2%	25MHz	400mA	1.47ohm	45	100MHz	375MHz
LQW2UASR68J00□	680nH ±5%	25MHz	400mA	1.47ohm	45	100MHz	375MHz
LQW2UASR75G00□	750nH ±2%	25MHz	360mA	1.54ohm	45	100MHz	360MHz
LQW2UASR75J00□	750nH ±5%	25MHz	360mA	1.54ohm	45	100MHz	360MHz
LQW2UASR82G00□	820nH ±2%	25MHz	400mA	1.61ohm	45	100MHz	350MHz
LQW2UASR82J00□	820nH ±5%	25MHz	400mA	1.61ohm	45	100MHz	350MHz
LQW2UASR91G00□	910nH ±2%	25MHz	380mA	1.68ohm	35	50MHz	320MHz
LQW2UASR91J00□	910nH ±5%	25MHz	380mA	1.68ohm	35	50MHz	320MHz
LQW2UAS1R0G00□	1000nH ±2%	25MHz	370mA	1.75ohm	35	50MHz	290MHz
LQW2UAS1R0J00□	1000nH ±5%	25MHz	370mA	1.75ohm	35	50MHz	290MHz
LQW2UAS1R2J00□	1200nH ±5%	7.9MHz	310mA	2ohm	35	50MHz	210MHz
LQW2UAS1R5J00□	1500nH ±5%	7.9MHz	330mA	2.3ohm	28	50MHz	120MHz
LQW2UAS1R8J00□	1800nH ±5%	7.9MHz	300mA	2.6ohm	28	50MHz	140MHz
LQW2UAS2R2J00□	2200nH ±5%	7.9MHz	280mA	2.8ohm	28	50MHz	130MHz
LQW2UAS2R7J00□	2700nH ±5%	7.9MHz	290mA	3.2ohm	22	25MHz	110MHz
LQW2UAS3R3J00□	3300nH ±5%	7.9MHz	290mA	3.4ohm	22	25MHz	90MHz
LQW2UAS3R9J00□	3900nH ±5%	7.9MHz	260mA	3.6ohm	20	25MHz	70MHz
LQW2UAS4R7J00□	4700nH ±5%	7.9MHz	260mA	4ohm	20	25MHz	60MHz

Operating Temperature Range (Self-temperature rise is not included): -55 to +125°C
Only for reflow soldering.

Continued on the following page. 

● This data sheet is applied for CHIP INDUCTORS (CHIP COILS) used for General Electronics equipment for your design.

Note:

- This datasheet is downloaded from the website of Murata Manufacturing co., ltd. Therefore, it's specifications are subject to change or our products in it may be discontinued without advance notice. Please check with our sales representatives or product engineers before ordering.
- This datasheet has only typical specifications because there is no space for detailed specifications. Therefore, please approve our product specifications or transact the approval sheet for product specifications before ordering.

 Continued from the preceding page.

■ Q-Frequency Characteristics (Typ.)

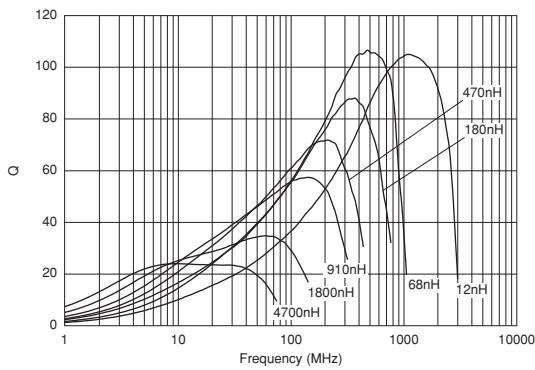

■ Inductance-Frequency Characteristics (Typ.)

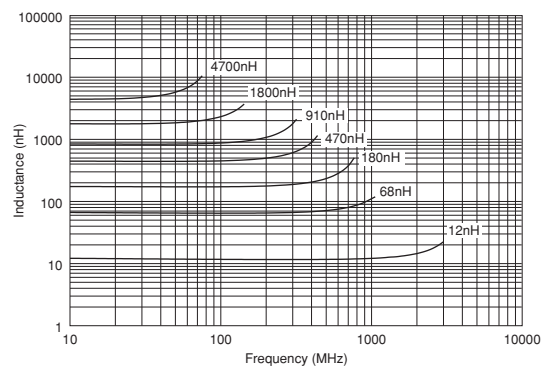

■ ⚠ Caution/Notice

⚠ Caution (Rating)

Do not use products beyond the rated current as this may create excessive heat.

Notice

Solderability of Tin plating termination chip might be deteriorated when low temperature soldering profile where peak solder temperature is below the Tin melting point is used. Please confirm the solderability of Tin plating termination chip before use.

● This data sheet is applied for CHIP INDUCTORS (CHIP COILS) used for General Electronics equipment for your design.

⚠ Note:

1. This datasheet is downloaded from the website of Murata Manufacturing co., ltd. Therefore, it's specifications are subject to change or our products in it may be discontinued without advance notice. Please check with our sales representatives or product engineers before ordering.
2. This datasheet has only typical specifications because there is no space for detailed specifications. Therefore, please approve our product specifications or transact the approval sheet for product specifications before ordering.