

SPECIFICATIONS

[1. General Specifications]

Product Name		Warning Light							
Model		LPT-1M1-□ (□: R, Y, G, B)				LPT-2M1-□ (□: R, Y, G, B)			
Rated Voltage		12 - 24V DC							
Operating Voltage Range		9.5 - 30V DC							
Rated Current Consumption	Luminous Color	Red (R)	Amber (Y)	Green (G)	Blue (B)	Red (R)	Amber (Y)	Green (G)	Blue (B)
	Max.	12V DC	0.30A	0.60A	0.50A	1.10A	1.30A	1.20A	
		24V DC	0.15A	0.30A	0.25A	0.55A	0.65A	0.60A	
Rated Power		Max.	3.6W	7.2W	6.0W	13.2W	15.6W	14.4W	
Operating Ambient Temperature		-30 °C ~ +75 °C							
Storage Ambient Temperature		-30 °C ~ +75 °C							
Mounting Location		Indoor / Outdoor *1							
Mounting Direction		All Directions							
Protection Rating		IP68(IEC 60529) (IPX8: 1 m underwater for 1 hour)							
		NEMA TYPE 4X,13							
Environmental Condition		All Directions (excluding end of the cable)							
Vibration Resistance		90m/s ²							
Luminous Intensity *2	Luminous Color	Red (R)	Amber (Y)	Green (G)	Blue (B)	Red (R)	Amber (Y)	Green (G)	Blue (B)
		500cd or more	550cd or more	850cd or more	300cd or more	1,650cd or more	1,800cd or more	2,800cd or more	1,000cd or more
Flash pattern (4 types) *3		Triple flash, Extreme Warning flash, Continuous, or Blinking (for details, refer to "4.1. Flash pattern". Factory default status: Triple flash)							
Flashing Rate (Typ.)		Triple / Extreme warning : 400 flashes per minute Blinking : 67 flashes per minute							
Dimmer Function		Yes							
Daisy-Chained	Number of units	Maximum 20 units (The LPT-1M1-□ and LPT-2M1-□ can be used together.)							
	Distance between units	Maximum 3 m							
	Flash group	Group A / Group B (for details, refer to "4.2. Flash group". Factory default status: Group A)							
	Multiple-unit operation	Synchronized / Alternating							
Setting	Items	Flash pattern , Flash group							
	Method	Each flash setting can be switched by applying voltage to the lead wire. (for details, refer to "Instruction manual".) When changing from factory settings, specify the flash settings before wiring the equipment. Also, while in operation, do not change flash patterns or flash group settings.							
Mass		72 g or less				130 g or less			
Outer Dimensions		Refer to the Outer Dimension Drawing							
Remarks		<p>*1 Install on a flat, sturdy surface. Be sure that the product is securely mounted when used where vibration is present.</p> <p>*2 Due to the characteristics of the LED elements, there may be a slight variation in color tone and brightness between units.</p> <p>*3 Flash Pattern (Triple flash / Blinking) meets SAE J595 Class 3.</p>							

Conformity Standards	EMC Directive (EN61000-6-4,EN61000-6-2) *4
	KC (KN61000-6-4,KN61000-6-2)
	FCC Part15 SubpartB Class A
	RoHS Directive (EN 50581)
	Photobiological safety of lamps and lamp systems(IEC 62471)
Remarks	<p>*4 EMC meets level ECE R10.05.</p> <p>- If the equipment used with this product requires power insulation, use an insulated power supply.</p>

[2. Model Number Configuration]

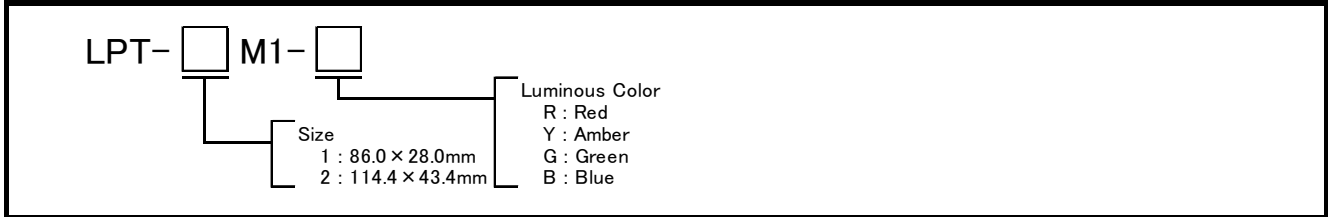

[3. Wiring Diagram]

3.1. When using 1 unit

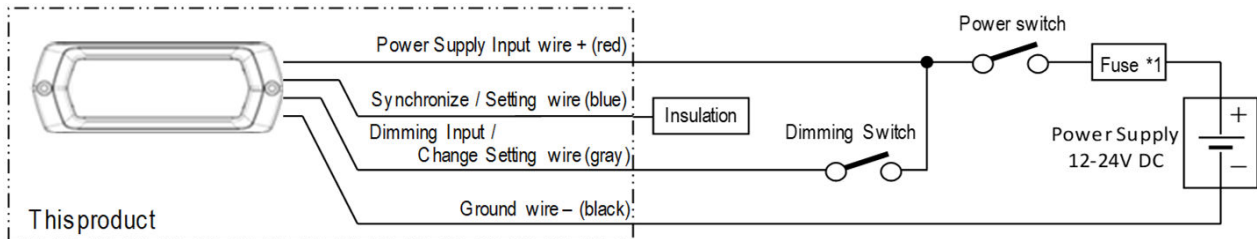

3.2. When using multiple units (2 or more, 5 or less) in a synchronous operation

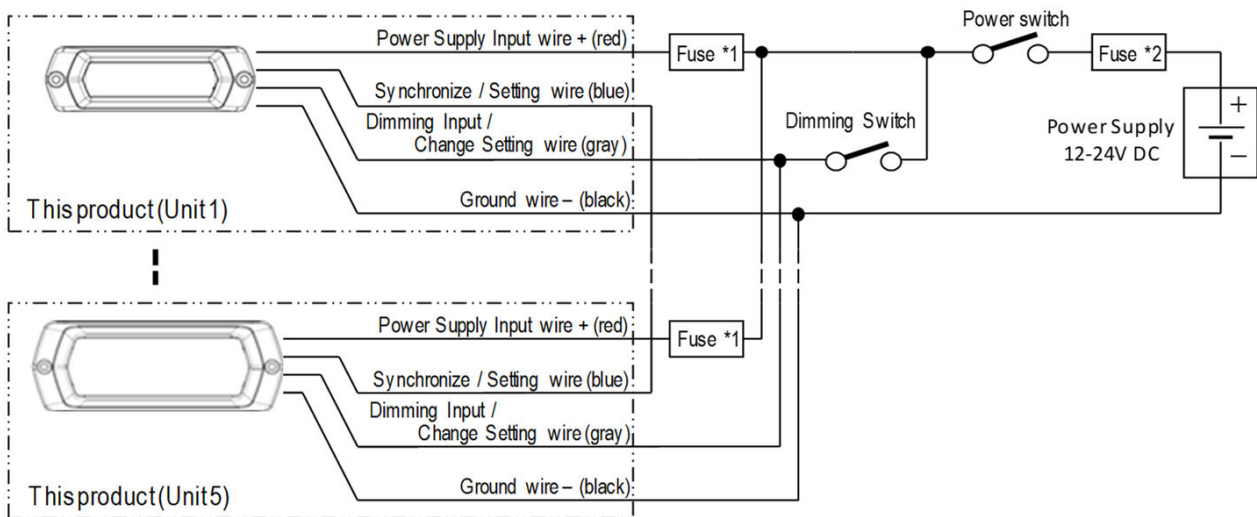

3.3. When using multiple units (6 or more, 20 or less) in a synchronous operation

- Distribute the power system into multiple system.
- You can connect up to 5 units per system. For 20 units, 4 systems are required.

Remarks	*1*2 : Wiring protection (Normal Blow).Please use if necessary.						
	<table border="1"> <tr> <td>*1</td> <td>LPT-1M1-□ : 1.0A</td> </tr> <tr> <td></td> <td>LPT-2M1-□ : 2.0A</td> </tr> </table>	*1	LPT-1M1-□ : 1.0A		LPT-2M1-□ : 2.0A	<table border="1"> <tr> <td>*2</td> <td>Consider the total current consumption of the equipment in use.</td> </tr> </table>	*2
*1	LPT-1M1-□ : 1.0A						
	LPT-2M1-□ : 2.0A						
*2	Consider the total current consumption of the equipment in use.						

[4. Flash Specifications]

4.1. Flash pattern

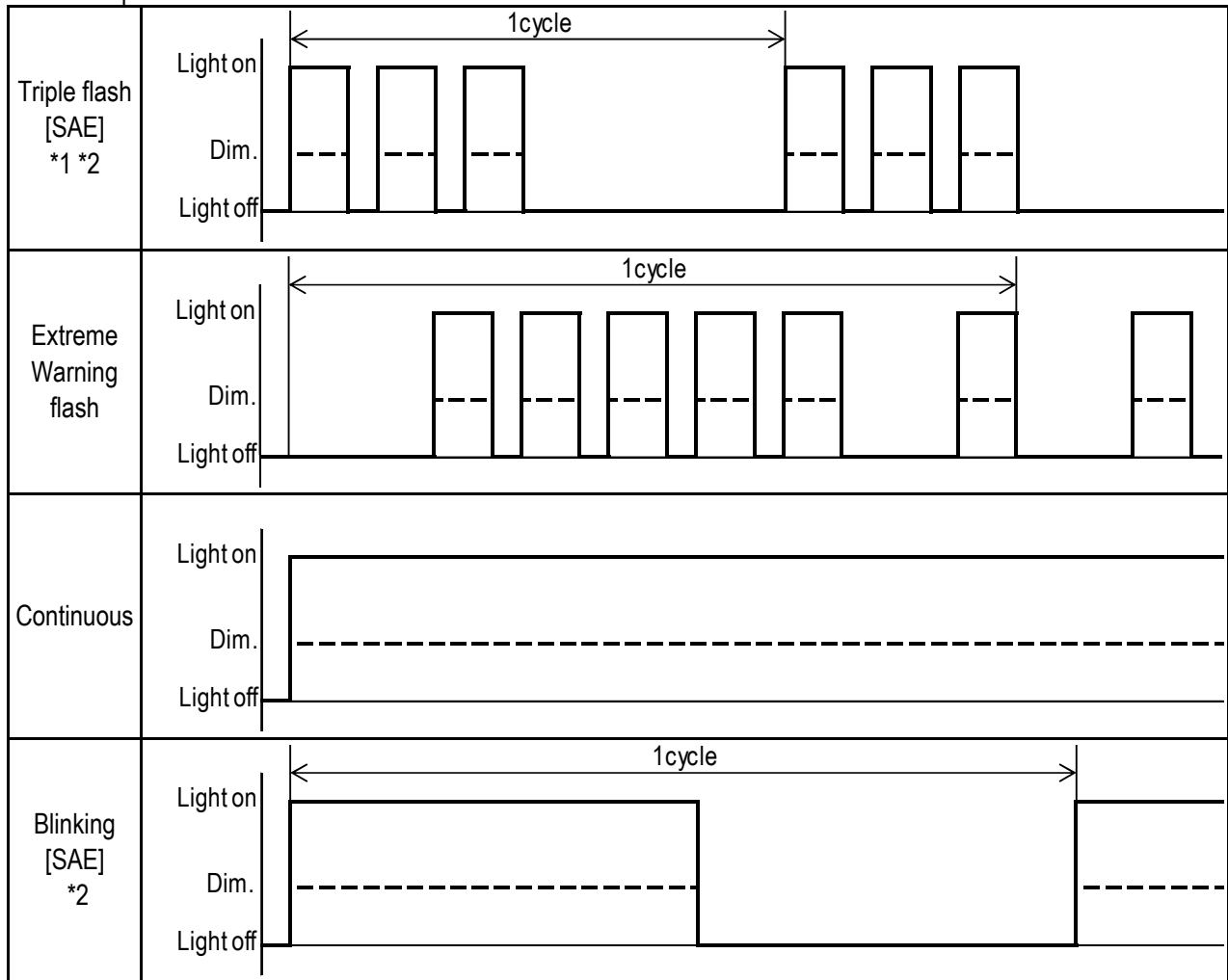

4.2. Flash group *3

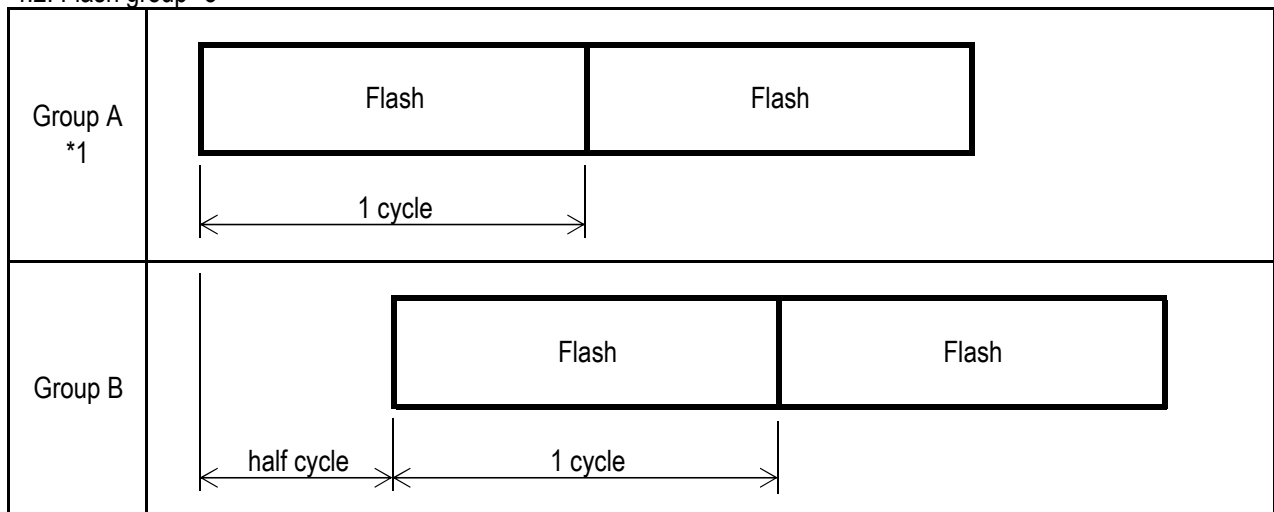

Remarks *1: Factory default status
 *2: Meets level SAE J595 Class3.
 *3:Excluding Continuous.

指定 外公差 General Tolerance	角度公差 ±[°]			寸法公差 ±[mm]					図番 Drawing No. LPT-1M1-W18	改訂 Rev. 年月日 Date 26.May.'20	改訂履歴 Revisions			
	短辺 長さ Length of short side	~	~100	6	30	120	300	1000						
	精 f	1	0.5	0.3	0.1	中 m	0.1	0.3				0.5	0.7	1
	粗 v	3	1.5	1	0.5	粗 c	0.3	0.5				1	1.2	2

A

B

C

D

E

F

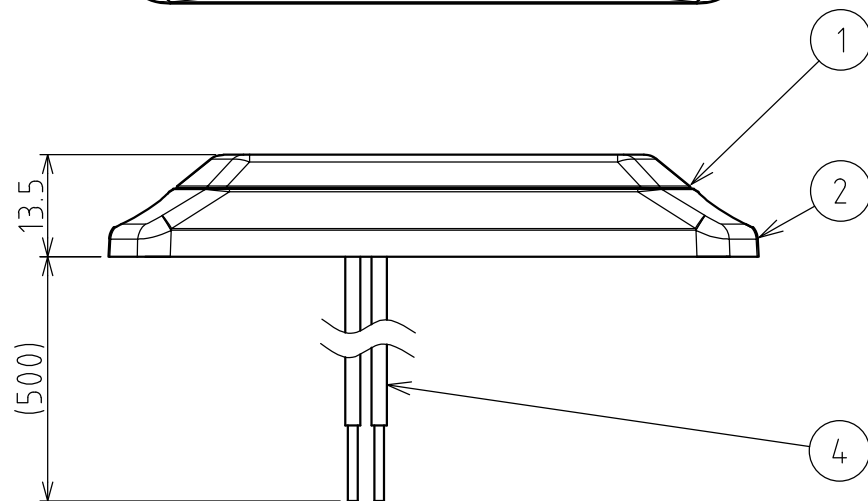
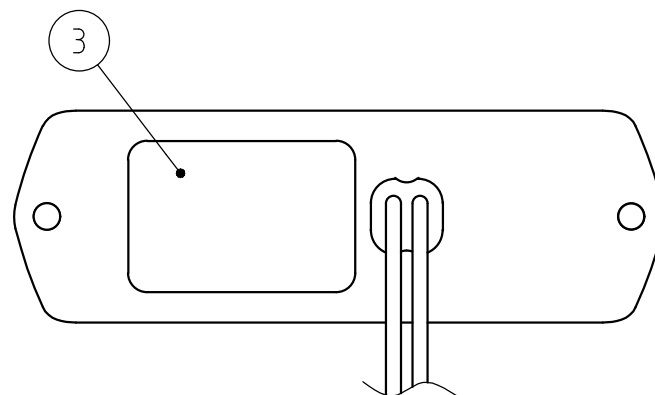
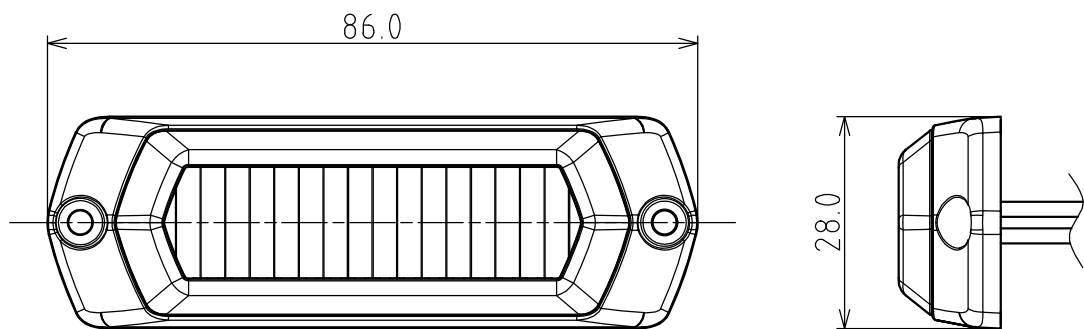

[Accessory List]

	Part Name	Qty.
a	Gasket	1
b	Pan Head Screw M3X25	2
c	O-ring	2
d	Plain Washer	2
e	Hexagon Nut M3	2

Secure the product in place referring to [Mounting part configuration diagram] using accessories included with the product.

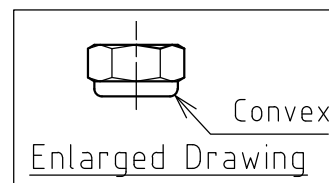
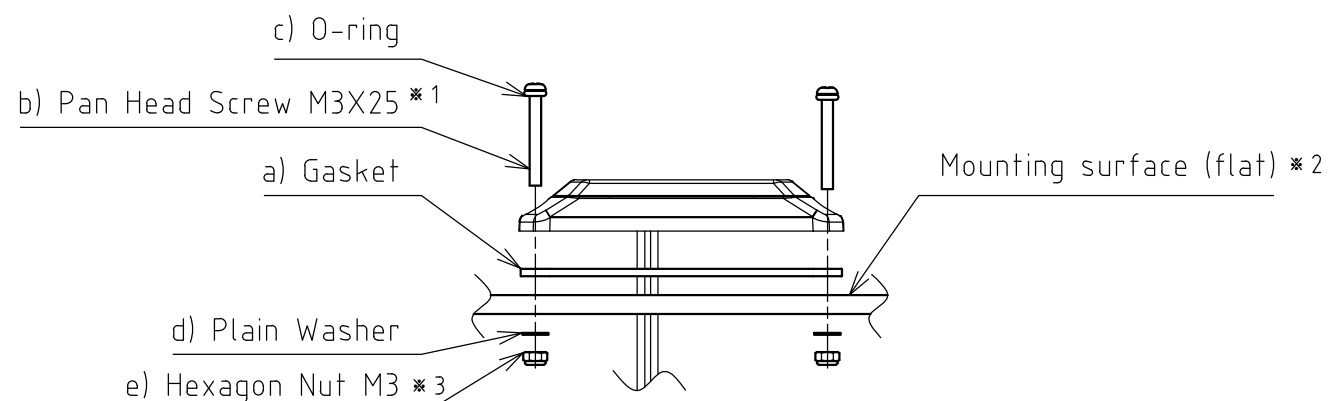

- *1 Tightening torque: 0.6N·m.
- *2 Maximum Board Thickness: 15mm.
- *3 There is a direction. Attach the convex side to the outside.

[Mounting part configuration diagram]

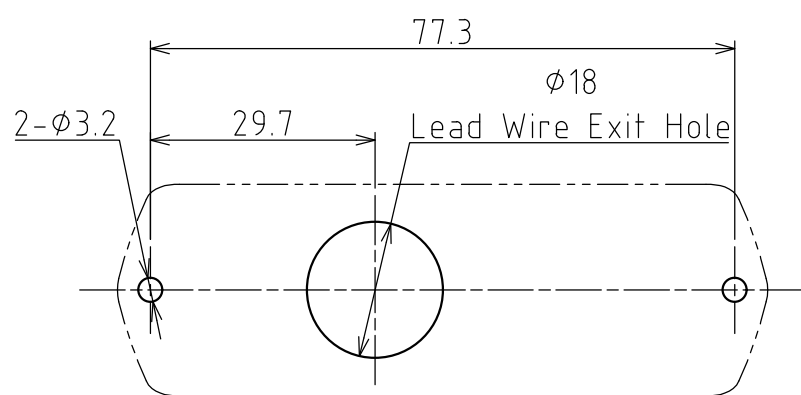

Prepare the mounting surface using the left dimensions.

[Mounting hole dimensions]

4	Lead Wire	4	AVS 0.5mm ² Stripped tips
3	Nameplate	1	-
2	Base	1	ADC12 (Black)
1	Lens	1	PC (Clear)
番号 No.	部品名 Part Name	数量 Qty.	記事 Remarks

機種 Model	LPT-1M1-□	特注No. S.P.No.	-	図名 Name	Outer Dimensing Drawing
品目コード Part No.	-	尺度 Scale	-	三角法 3rd Angle P.	単位 Unit mm
				株式会社 PATLITE Corporation	Ver.2.2 A3

1

2

3

4

5

6

7

8

指定公差 General tolerance	角度公差 ±[°]			寸法公差 ±[mm]					図番 Drawing No. LPT-1M1-W18	改訂履歴 Revisions			
	短辺長さ Length of short side	~	~100	6	30	120	300	1000					
	精 f	1	0.5	0.3	0.1	中 m	0.1	0.3			0.5	0.7	1
	粗 v	3	1.5	1	0.5	粗 c	0.3	0.5			1	1.2	2

改訂 Rev.	年月日 Date	改訂履歴 Revisions
	26.May.'20	

A
B
C
D
E
F

A
B
C
D
E
F

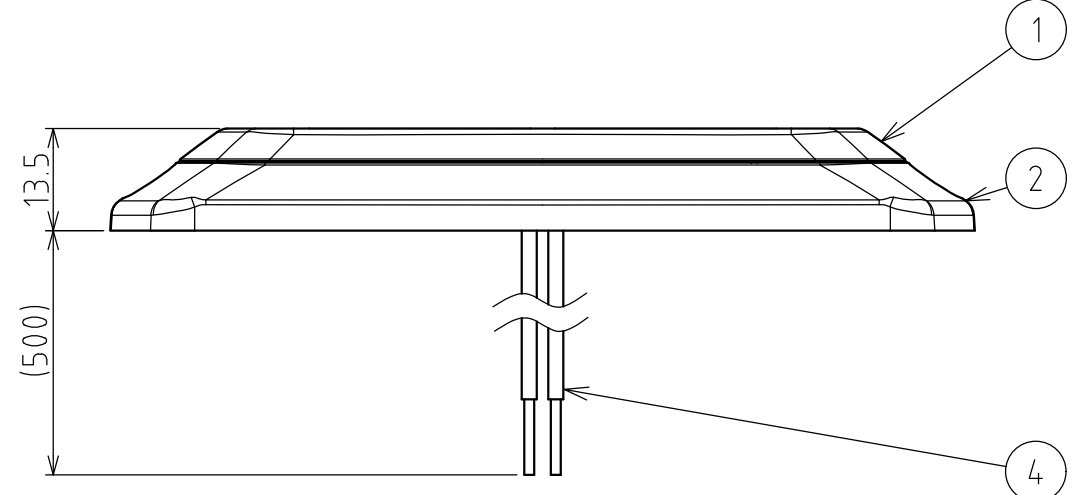
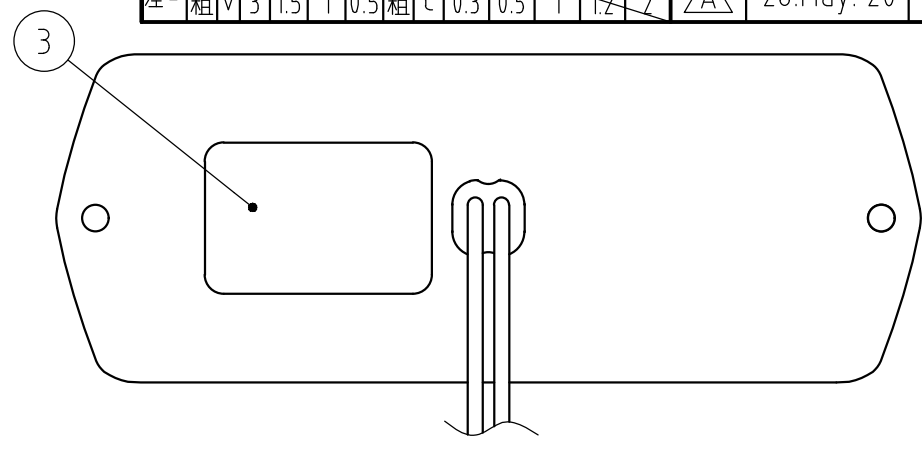
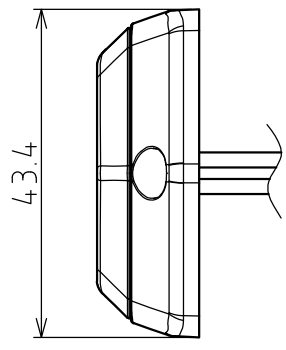
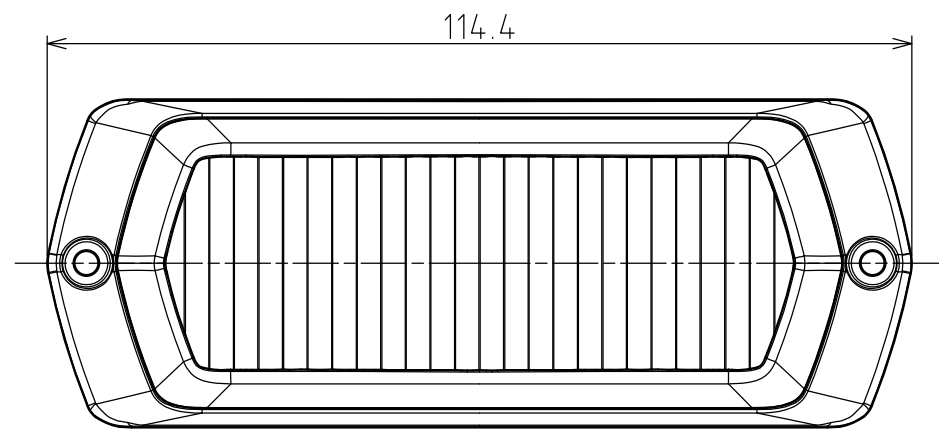

[Accessory List]

	Part Name	Qty.
a	Gasket	1
b	Pan Head Screw M3X25	2
c	O-ring	2
d	Plain Washer	2
e	Hexagon Nut M3	2

Secure the product in place referring to [Mounting part configuration diagram] using accessories included with the product.

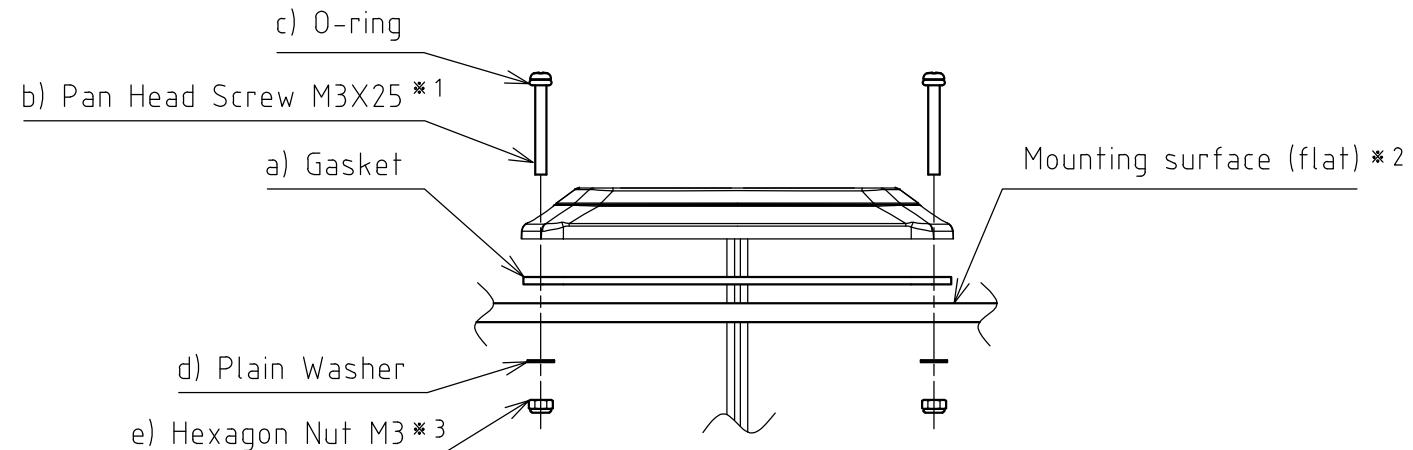

- *1 Tightening torque: 0.6N·m.
- *2 Maximum Board Thickness: 15mm.
- *3 There is a direction. Attach the convex side to the outside.

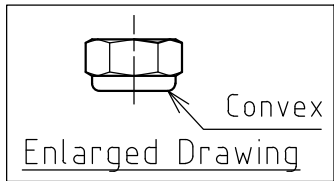

[Mounting part configuration diagram]

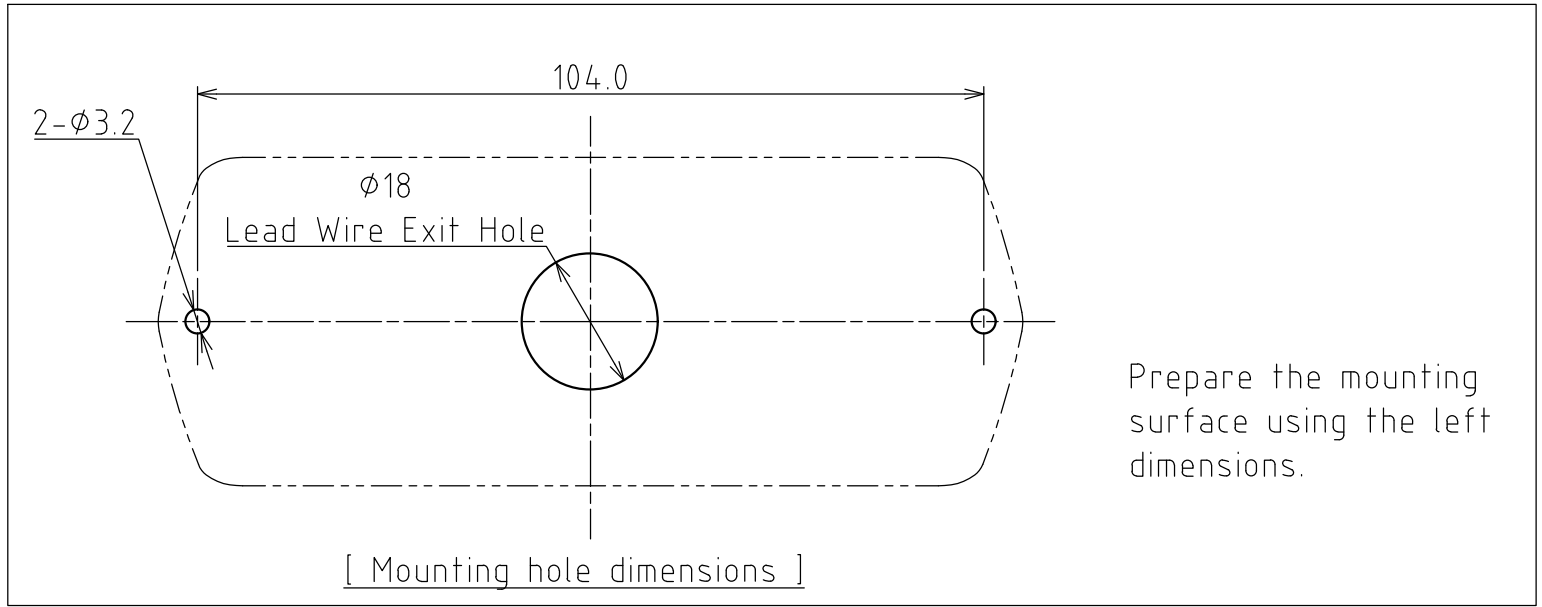

Prepare the mounting surface using the left dimensions.

4	Lead Wire	4	AVS 0.5mm ² Stripped tips
3	Nameplate	1	-
2	Base	1	ADC12 (Black)
1	Lens	1	PC (Clear)
番号 No.	部品名 Part Name	数量 Qty.	記事 Remarks

機種 Model	LPT-2M1-□	特注No. S.P.No.	-	図名 Name	Outer Dimensing Drawing
品目コード Part No.	-	尺度 Scale	-	三角法 3rd Angle P.	単位 Unit mm
					株式会社 パトライト PATLITE Corporation

1

2

3

4

5

6

7

8