

DASH NO.

M CODE

MADE FROM

S-D

KTH-2025

## REVISIONS

NO.	CHANGES
2	CN. 27545 C SD 8 NOV 85

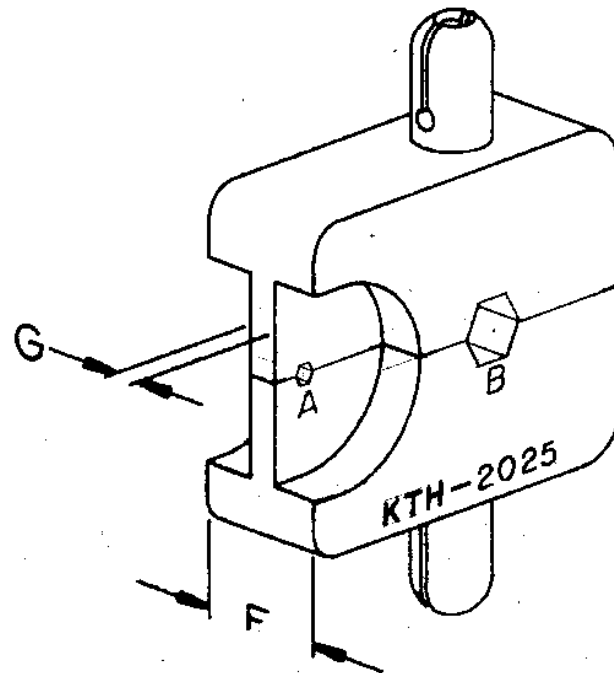

S-D

SCALE 2:1

USED ON:

REF:

## CRIMP DIE

DRAWN M.D.

DATE 2BAUG 81

APPR.

DATE

**KINGS**  
ELECTRONICS CO. INC.  
YONGE, NEW YORK 10984

KTH-2025

## NOTES:

1. FOR USE WITH RG-122, 180, 195, AMPHENOL 21-597 & RACHEM 09-026 CABLE.

HEX SIZES (ACROSS FLATS)				DIE WIDTH	DIE WIDTH			
A	B	C	D	F	G	H	I	
.042	.178	—	—	.400	.080	—	—	

## UNLESS OTHERWISE SPECIFIED:

1. TOLERANCES: FRACTIONS & 2 PLACE DECIMALS  $\pm .010$   
3 PLACE DECIMALS  $\pm .004$  ANGLES  $\pm 0^{\circ}30'$   
T. I. R. CONCENTRICITY OF ANY 2 DIAMETERS MAY NOT EXCEED HALF THE SUM OF THEIR TOLERANCES.

2. REMOVE ALL BURRS, BREAK SHARP EDGES .005 MAX.  
3. NO FILLETS PERMITTED.  
4. SURFACE ROUGHNESS 63 MICROINCHES RMS MAX.  
5. ALL DIMENSIONS PRIOR TO PLATING.  
6. ALL PLATING IN ACCORDANCE WITH KER 10004.