

Recycling (Pulse Generator) KSDR Digi-Timer Timing Module



- ON Delay and OFF Delay Independently Adjustable
- ON Time or OFF Time First
- Low Cost, Digital Circuitry
- Delays from 0.1 s ... 1000 m
- +/-0.5% Repeat Accuracy
- Totally Solid State & Encapsulated Circuitry

Description

The KSDR is an extended version of the TSDR Series, for those demanding systems requiring low cost and flexibility. Independent time adjustment of both delay periods allows precise, efficient control for both automatic and manual adjustment systems. The KSDR is recommended for air drying, automatic oiling, life testing, chemical metering, and automatic duty cycling.

Operation

Upon application of input voltage, the output is energized and the ON time begins. At the end of the ON time, the output de-energizes and the OFF time begins. At the end of the OFF time, the output is energized and the cycle repeats as long as input voltage is applied. The OFF time may be the first delay in some recycling timers.

Reset: Removing input voltage resets the output and time delays, and returns the sequence to the first delay.

- Approvals:

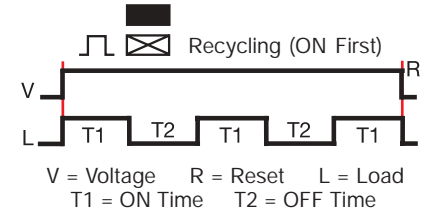
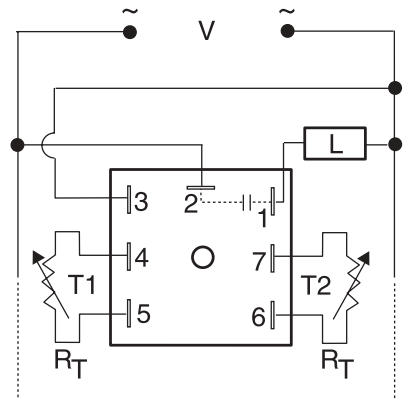

Ordering Table

KSDR Series	X Input	X ON Time	X Operating Sequence	X OFF Time
	-2 - 24 V AC	-0 - 0.1 ... 10 s	-A - ON Time First	-0 - 0.1 ... 10 s
	-4 - 120 V AC	-1 - 1 ... 100 s	-B - OFF Time First	-1 - 1 ... 100 s
	-6 - 230 V AC	-2 - 10 ... 1000 s		-2 - 10 ... 1000 s
		-3 - 0.1 ... 10 m		-3 - 0.1 ... 10 m
		-4 - 1 ... 100 m		-4 - 1 ... 100 m
		-5 - 10 ... 1000 m		-5 - 10 ... 1000 m

Example P/N: **KSDR40A1**

Technical Data

Time Delay	
Type	Digital integrated circuitry
Range	0.1 s ... 1000 m in 6 ranges Note: Range 0 and 5 may not be combined in the same unit
Repeat Accuracy	+/-0.5%
Tolerance (Factory Calibration)	≤ +/-10%
Reset Time	150 ms
Time Delay vs. Temperature & Voltage	≤ +/-10%
Input	
Voltage	24, 120, or 230 V AC
Tolerance	+/-20%
Line Frequency	50 ... 60 Hz
Output	
Type	Solid state
Rating	1 A steady state, 10 A inrush at 55°C
Voltage Drop	≅ 2.5 V at 1 A
Protection	
Circuitry	Encapsulated
Dielectric Breakdown	≥ 2000 V RMS terminals to mounting surface
Insulation Resistance	≥ 100 MΩ
Mechanical	
Mounting	Surface mount with one #10 (M5 x 0.8) screw
Package	2 x 2 x 1.21 in. (50.8 x 50.8 x 30.7 mm)
Termination	0.25 in. (6.35 mm) male quick connect terminals
Environmental	
Operating Temperature	-40°C ... +75°C
Storage Temperature	-40°C ... +85°C
Humidity	95% relative, non-condensing
Weight	≅ 2.4 oz (68 g)

ON Time	
Time Delay	VTP P/N
0 - 0.1 ... 10 s	VTP5C
1 - 1 ... 100 s	VTP5G
2 - 10 ... 1000 s	VTP5K
3 - 0.1 ... 10 m	VTP5N
4 - 1 ... 100 m	VTP5P
5 - 10 ... 1000 m	VTP5R

OFF Time	
Time Delay	VTP P/N
0 - 0.1 ... 10 s	VTP5C
1 - 1 ... 100 s	VTP5G
2 - 10 ... 1000 s	VTP5K
3 - 0.1 ... 10 m	VTP5N
4 - 1 ... 100 m	VTP5P
5 - 10 ... 1000 m	VTP5R

R _T Selection Chart						
Desired Time Delay*						R _T Megohm
Seconds		Minutes				
0	1	2	3	4	5	
0.1	1	10	0.1	1	10	0.0
1	10	100	1	10	100	0.5
2	20	200	2	20	200	1.0
3	30	300	3	30	300	1.5
4	40	400	4	40	400	2.0
5	50	500	5	50	500	2.5
6	60	600	6	60	600	3.0
7	70	700	7	70	700	3.5
8	80	800	8	80	800	4.0
9	90	900	9	90	900	4.5
10	100	1000	10	100	1000	5.0

NOTE: Time ranges 0 & 5 cannot be ordered in the same unit.
* When selecting an external R_T add at least 20% for tolerance of unit and the R_T.

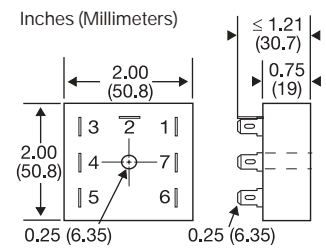

Accessories

- Mounting bracket
P/N: P1023-6
- External adjust potentiometer
P/Ns: P1004-13 (fig A) P1004-13-X (fig B)
- Female quick connect
P/N: P1015-64(AWG14/16)
- Plug-on adjustment module
P/N: VTP(X)(X)
- Quick connect to screw adaptor
P/N: P1015-18
- Versa-knob
P/N: P0700-7
- DIN rail adaptor
P/N: P1023-20

DIN rail P/Ns: C103PM(AI) 17322005 (Steel)

See accessory pages at the end of this section.