

DASH NO.	M CODE	MADE FROM
----------	--------	-----------

GSD

M39012/21-0002

REVISIONS

ISSUE	CHANGES
9	CN 33274 E REDRAWN WJM 08/05/91

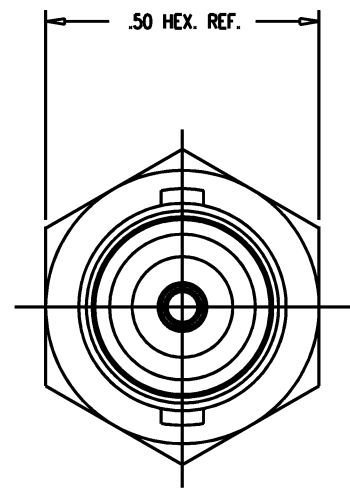
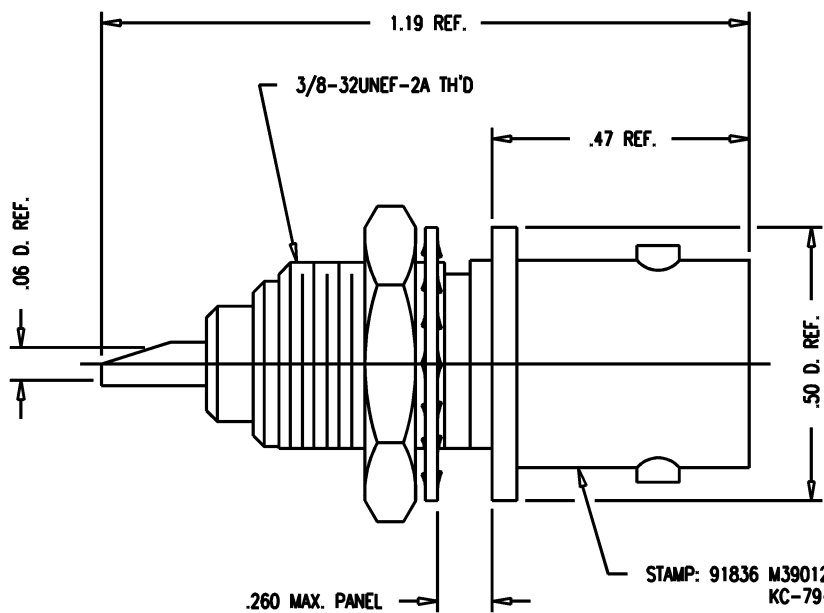

STAMP: 91836 M39012/21-0002
KC-79-106 XX XX
DATE CODE

- NOTES:**
- INTERFACE PER MIL-STD-348, FIG. 301-2.
 - MATERIALS:**
INSULATOR: TEFLON, ASTM-D-1457
LOCKWASHER: PHOSPHOR BRONZE, QQ-B-750
CENTER CONTACT: BER. COPPER, ASTM-B-196
ALL OTHER METAL PARTS: BRASS, ASTM-B16
 - FINISHES:**
CENTER CONTACT: HARD GOLD PLATE, PER MIL-G-45204
ALL OTHER METAL PARTS: SILVER PLATE, PER QQ-S-365
 - ELECTRICAL CHARACTERISTICS:**
NOMINAL IMPEDANCE: 50 OHMS
WORKING VOLTAGE: 500 VRMS
FREQUENCY RANGE: DC TO 4 GHz.

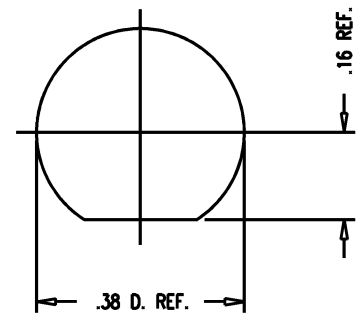

MOUNTING HOLE

GSD

SCALE 4:1

APPROX SURFACE AREA

KC-79-106

USED ON

REF: SUPERSEDES UG-1094A/U

RECEPTACLE, BULKHEAD, BNC

DRAWN WJM	DATE 08/05/91
-----------	---------------

DESIGN MJB	DATE 08/22/91
------------	---------------

APPR.	DATE
-------	------

KINGS
ELECTRONICS CO., INC.
TUCKAHOE, NEW YORK 10707

M39012/21-0002