

DASH NO.	M CODE	MADE FROM
----------	--------	-----------

GSD

M39012/16-0004

REVISIONS

ISSUE	CHANGES
9	CN 39853 C REDRAWN DRK 03/21/07

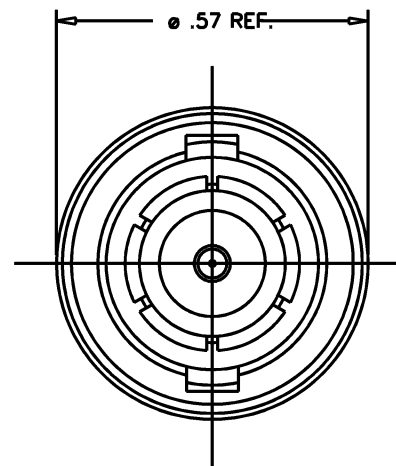
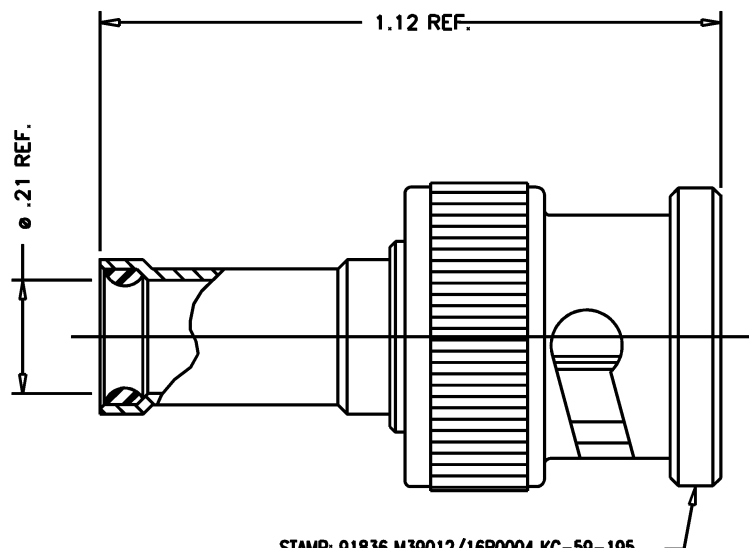

STAMP: 91836 M39012/1680004 KC-59-195

NOTES:

1. FOR USE WITH RG-58, 58A, 58C, 141 & 141A/U CABLE.
2. FOR CABLING INSTRUCTIONS SEE CP-401.
3. FOR CRIMPING USE DIE SIZE 61.
4. INTERFACE PER MIL-STD-348, FIG. 301-1.
5. MATERIALS:
 - INSULATOR: TEFLON, ASTM-D4894.
 - GASKET: SIL. RUB., A-A-59588.
 - K-GRIP SLEEVE: COM. BRONZE, ASTM-B140.
 - OUTER CONTACT } BER. COP., ASTM-B196
 - SPRING WASHER }
 - ALL OTHER METAL PARTS: BRASS, ASTM-B16
6. FINISHES:
 - CENTER CONTACT: GOLD ASTM-B488.
 - ALL OTHER METAL PARTS: SILVER, ASTM-B700.
7. ELECTRICAL CHARACTERISTICS:
 - NOMINAL IMPEDANCE: 50 OHMS
 - WORKING VOLTAGE: 500 VRMS
 - FREQUENCY RANGE: DC TO 4 GHz

SCALE 4:1

APPROX SURFACE AREA

KC-59-195

USED ON

REF:

PLUG, BNC

DRAWN DRK 03/21/07

DESIGN LI 06/19/71

APPR. DATE

KINGS
ELECTRONICS CO., INC.
ROCK HILL, SOUTH CAROLINA 29730

GSD

M39012/16-0004